

**PROCEEDINGS OF THE FIFTH SYMPOSIUM OF THE INTERNATIONAL
WORKING GROUP ON PLANT VIRUSES WITH FUNGAL VECTORS.**

Editors: C. M. Rush and U. Merz

Institute of Plant Sciences, Swiss Federal Institute of Technology (ETH),
Zurich, Switzerland

July 22-25, 2002

2003 American Society of Sugar Beet Technologists
800 Grant Street, Suite 300, Denver, CO 80203
Printed in U.S.A.

ISBN: 0-9639572-1-X

PREFACE

The International Working Group on Plant Viruses with Fungal Vectors (IWGPVFFV) was formed in 1988 at Kyoto, Japan, with Dr. Chuji Hiruki as the chairperson. The goal of the working group is to provide a forum to facilitate international collaboration and multidisciplinary research on plant viruses with fungal vectors. Thus, topics at symposia have included a) biology of viruses with fungal vectors, b) biology of fungi that transmit plant viruses, c) interaction between these viruses and vectors, and d) epidemiology and control of diseases caused by plant viruses transmitted by soilborne fungi.

Symposia of the working group have been held at the Biologische Bundesanstalt (BBA) in Braunschweig, Germany (1990), McGill University in Montreal, Canada (1993), The West Park Conference Centre, University of Dundee, Dundee, Scotland (1996), Asilomar Conference Center in Monterey, California (1999), and most recently at the Institute of Plant Sciences, Swiss Federal Institute of Technology (ETH), Zurich, Switzerland (2002). This volume serves as a record of material presented at this most recent meeting for use by members of the IWGPVFFV and for those with an interest in the activities of the IWGPVFFV.

As the IWGPVFFV is a totally volunteer group, the success of its meetings is a result of hard work and contributions of the local organizing committee and sponsors. Those responsible for the success of the most recent meeting are listed on the next page. The names and e-mail addresses of the current program committee are also listed. Please contact a member of the program committee if you wish to be included in any future mailings of the IWGPVFFV. The next symposium is scheduled for 2005.

Charles M. Rush
Proceedings Editor

SPONSORS

BIOREBA AG

UBS AG

SESSION CHAIRPERSONS

Virus Genetics

Mike Adams

Detection/Quantification

Alison Lees

Host-Vector/Virus Interactions

Gail Wisler

Virus Characterization

D'Ann Rochon

Disease Control

John Walsh

LOCAL ARRANGEMENTS

Dr. Ueli Merz

PROGRAM COMMITTEE

Dr. Ueli Merz

Ueli.merz@ipw.agrl.ethz.ch

Dr. Charlie Rush

cm-rush@tamu.edu

Dr. Gail Wisler

gwisler@pwa.ars.usda.gov

Contents

Page

Preface

Acknowledgements

Virus genetics

A new wheat-infecting furovirus which is rapidly spreading in the north eastern U.S.A. differs considerably from the type strain of *Soilborne wheat mosaic virus* in the nucleotide sequences of various genes, but not in the deduced amino acid sequences of the corresponding gene products
R. Koenig, G.C. Bergstrom, S.M. Gray and S. Loss 1

Single amino acid changes in the 25 protein of *Beet necrotic yellow vein virus* determine resistance responses of *Beta vulgaris* spp. *maritima*
S. Chiba, M. Miyanishi, H. Kondo and T. Tamada 5

Sequences analysis of Belgian *BNYVV* and development of a simultaneous detection of soilborne sugar-beet viruses by RT-PCR
A. Meunier, J.-F. Schmit and C. Bragard 9

Pathogenicity and molecular variability of *Beet necrotic yellow vein virus* isolates from Europe, Japan, China and the United States
T. Tamada, M. Miyanishi, H. Kondo, H. Chiba, and C. G. Han, 13

Mutation of pro-73 in the arm region of the *Cucumber necrosis virus* coat protein results in particles with an altered swollen conformation and loss of fungus transmissibility
K. Kakani and D'A. Rochon 17

Analysis of RNA1 of *Lettuce big-vein virus*, genus *Varicosavirus* reveals its relation to *rhabdoviruses*
T. Sasaya, K. Ishikawa and H. Koganezawa 21

A database and web site for plant virus sequence analysis
M. J. Adams and J. F. Antoniw 25

Detection/quantification

Development of diagnostics for the detection and quantification of *Olpidium brassicae*
L. Nott, J. Bambridge and J.A. Walsh 29

The development of a quantitative real-time PCR assay for *Spongospora subterranea* f.sp. *subterranea* and its use in epidemiological studies
A.K. Lees, P. van de Graaf, D.W.Cullen and J.M.Duncan 31

Improved immunological diagnostics for *Spongospora subterranea*
U. Merz and J.A. Walsh 35

Broad-spectrum detection of <i>Polymyxa</i> species and form species by polymerase chain reaction	40
A.Legrève, P. Delfosse, V. Van Hese, C. Bragard and H. Maraite	
The use of low altitude aerial photography and remote sensing to study the spatial distribution of soilborne viruses	44
P. Delfosse, B. Gérard, A.S. Reddy, S. Schnock, A. Legrève and C Bragard	
Host-vector/virus interaction	
Analysis of <i>Soilborne wheat mosaic virus</i> 37K and coat protein: virus movement and transgenic resistance	48
H. An, A. Guenzi and J. Verchot-Lubicz	
Reactions to <i>SBWMV</i> of durum wheat cultivars grown during 2000/2001 in northern Italy	52
V. Vallega, C. Rubies Autonell and C. Ratti	
Interactions between <i>Beet necrotic yellow vein virus</i> and <i>Beet soilborne mosaic virus</i> and their effect on virus levels in sugar beet	56
G. C. Wisler, R. T. Lewellen, J. L. Sears, H.-Y. Liu, J. W. Wasson and W. M. Wintermantel	
Virus Characterization	
Experiences in the search for possibly occurring recombinations between a and b type <i>Beet necrotic yellow vein virus</i> in transgenic and mixed infected sugarbeets	60
R. Koenig, G. Büttner and S. Loss	
Partial characterization of <i>Cucumber necrosis virus</i> binding sites on zoospores of the fungal vector <i>Opidium bornovanus</i>	64
D'A. Rochon, K. Kakani and R. Reade	
<i>Ophioviruses</i> : hiding in the background, emerging from the underground	68
Robert G. Milne	
Control	
Characterisation of resistance to <i>Barley mild mosaic virus</i>	72
G.R.D. McGrann and M.J. Adams	
Isolation and characterization of genes induced during non-host resistance to <i>Polymyxa</i> spp	76
C.S. Kingsnorth, E.S. Mutasa-Göttgens and M.J.C. Asher	
Rna1 determines the ability of <i>Barley yellow mosaic virus</i> 2 to overcome the <i>rym4</i> resistance gene in barley	80
T. Kühne and G. Proeseler	

Virus resistance in transgenic plants expressing <i>Beet necrotic yellow vein virus</i> coat protein readthrough domain Andika, I. B., Kondo, H., Suzuki, N. and Tamada, T.	84
Effect of environmental factors on infection of potato by <i>Spongospora subterranea</i> f.sp. <i>subterranea</i> , the vector of PMTV P. van de Graaf, A. Lees and J. Duncan	88
Posters	
Possible role of induced proteins displaying chitinase and B-1,3-glucanase activities in resistance to rhizomania L. Burketova, K. Stillerova, M. Sindelarova	92
The development of a quantitative ELISA for the detection of <i>Polymyxa betae</i> Crawford S. Kingsnorth, Effie S. Mutasa-Göttgens, Daph M. Chwarszczynska and Mike J.C. Asher	96
Study of host range of the <i>Beet soilborne pomovirus</i> P. Kudlackova and P. Rysanek	100
Electronmicroscopic study of <i>Beet soilborne pomovirus</i> Pavla Kudlackova, Miloslav Zouhar and Pavel Rysanek	103
Partial characterization of an unnamed soil-borne sugar beet virus in the United States Hsing-Yeh Liu, J. L. Sears, and R. T. Lewellen	107
Development of a direct detection method for <i>Polymyxa</i> spp. in soil L. Ward, M. Fenn and C.M. Henry	111
Differences in zoosporangial root infection of some potato varieties inoculated with Japanese and foreign field isolates of <i>Spongospora subterranea</i> f. sp. <i>subterranea</i> Takato Nakayama, Ueli Merz, Akio Nakagawa, Toshiaki Takehara and Tadayuki Shimanuki	115
Investigation of epidemiology of <i>Soilborne cereal mosaic virus</i> in the German country Saxony-Anhalt U. Kastirr, F. Rabenstein, T. Kühne	119
Spatial association and distribution of <i>Beet necrotic yellow vein virus</i> and <i>Beet soilborne mosaic virus</i> in sugar beet fields F. Workneh, E. Villanueva, and C. M. Rush	123
Physiology of pigments in sugar beets infected with <i>rhizomania</i> K. Steddom, G. Heidel, D. Jones, and C. M. Rush	127
<i>Tombusvirus</i> infection of lettuce is influenced by soil salinity William M. Wintermantel and Amy G. Anchieta	131

A NEW WHEAT-INFECTING FUROVIRUS WHICH IS RAPIDLY SPREADING IN THE NORTH EASTERN U.S.A. DIFFERS CONSIDERABLY FROM THE TYPE STRAIN OF *SOILBORNE WHEAT MOSAIC VIRUS* IN THE NUCLEOTIDE SEQUENCES OF VARIOUS GENES, BUT NOT IN THE DEDUCED AMINO ACID SEQUENCES OF THE CORRESPONDING GENE PRODUCTS.

R. Koenig¹, G.C. Bergstrom², S.M. Gray³ and S. Loss¹

¹c/o Biologische Bundesanstalt für Land- und Forstwirtschaft, Messeweg 11, D-38104 Braunschweig, ²Department of Plant Pathology, Cornell University, Ithaca, NY 14853-4203, U.S.A and ³USDA, ARS, Cornell University, Ithaca, NY 14853-4203, U.S.A

Summary

A wheat-infecting furovirus which was found to be rapidly spreading in upper New York State, U.S.A, was identified as a deviating strain of *Soilborne wheat mosaic virus* (SBWMV) by means of sequence analyses of portions of its RNA 1 and 2. The nucleotide sequences of several of its genes differed by 9 to 12 % from those of the corresponding genome regions of the Nebraska type strain of SBWMV. The deduced amino acid sequences of the putative translation products, however, suggested much closer relationships. Thus, the amino acid sequences of the coat proteins of the two virus strains were 100% identical despite the fact that their coding regions differed in as many as 68 nucleotide positions. The New York (NY) strain of SBWMV is possibly closely related to a virus source from Illinois for which so far only the nucleotide sequences of its coat protein gene and the 5' untranslated region of its RNA 2 are known.

Introduction

Soilborne wheat mosaic virus (SBWMV) is common throughout many regions of the United States but in New York State it had not been found during an extensive survey of wheat viruses conducted in 1988-1989 (Miller et al., 1991). Since 1998, however, a soilborne virus which reacts with antisera to SBWMV was found to be rapidly spreading in varieties of winter wheat, barley, rye and triticale in this area. Preliminary evaluations of resistance and susceptibility of wheat cultivars suggested that this virus may differ from the SBWMV found in other areas of the United States. Molecular analyses of portions of RNA 1 and 2 of this virus indicate that it represents a strain of SBWMV which is distinct from the Nebraska type strain (Shirako and Wilson, 1993), but may be closely related to an Illinois virus source for which so far only the coat protein gene and the 5' untranslated region of its RNA 2 have been analysed (Shirako, 1998).

Materials and Methods

For each of the two viral RNAs, two genome areas were amplified by means of immunocapture RT PCR. They comprise the entire genes for the movement protein, the coat protein, the cystein-rich protein and portions of the genes for the replicase and the coat protein readthrough protein (Fig. 1). A detailed description of the methods used has been given by Koenig et al. (2002).

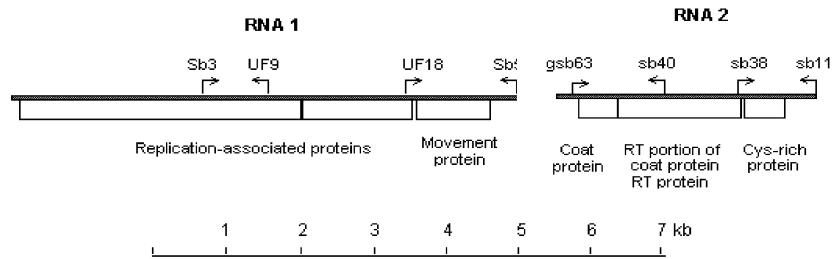

Fig. 1. Position of primers, used for the amplification of various genome areas of the NY strain of SBWMV, on the full length sequences of RNA 1 and 2 of the Nebraska type strain of SBWMV. Modified from Koenig *et al.* (2002).

Results and Discussion

With the primers described in Fig. 1 the NY virus isolate yielded immunocapture RT-PCR products of the expected sizes. Their sequences were compared with those of the respective genome regions of the other cereal-infecting furoviruses which have been fully sequenced so far, i.e. of SBWMV-Nebraska (Shirako and Wilson, 1993), SBWMV-Jap (Shirako *et al.*, 2000), SBCMV (Diao *et al.*, 1999a; Koenig *et al.*, 1999), *Chinese wheat mosaic* (CWMV) (Diao *et al.*, 1999b), *Oat golden stripe* (OGSV) (Diao *et al.*, 1999a) and *Sorghum chlorotic spot* (SrCSV) (Shirako *et al.*, for the coding sequences of the movement protein genes as representatives

A. MOVEMENT PROTEINS

A. NUCLEOTIDE SEQUENCES OF CODING REGIONS
B. AMINO ACID SEQUENCES

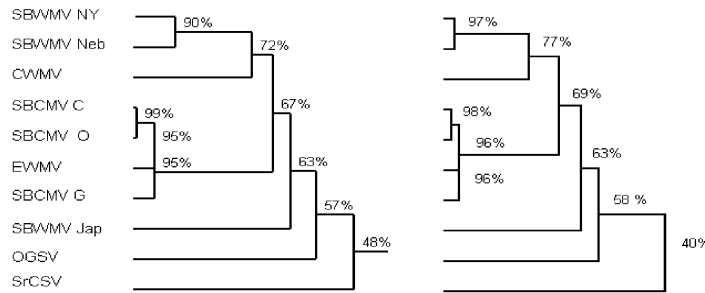

B. COAT PROTEINS

A. NUCLEOTIDE SEQUENCES OF CODING REGIONS
B. AMINO ACID SEQUENCES

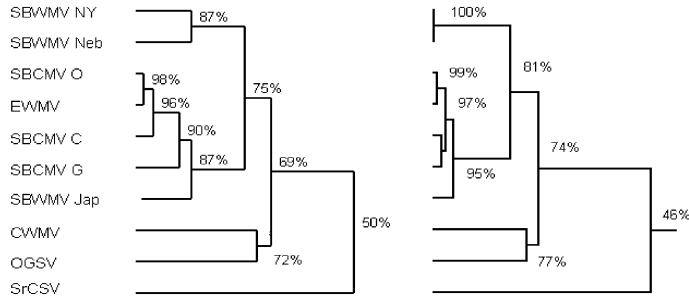

Fig. 2. Trees showing the groupings of the furoviruses analyzed so far based on the percentages of identity in the nt sequences of the coding regions (left sites) and in the deduced amino acid sequences (right sites) for one protein each encoded on RNA 1 (i.e. the movement proteins) and on RNA 2 (i.e. the coat proteins), respectively. Similar groupings were obtained for these as well as other genome regions when a neighbor-joining analysis was made. From Koenig *et al.* (2002).

2000) *viruses*. The closest relationships were found with SBWMV-Nebraska. This is shown for RNA 1 and the coat protein genes as representatives of RNA 2 in Fig. 2Aa and Ba. Similar groupings were seen for each of the two RNAs when other regions were analysed and when the trees were based on neighbor-joining analyses rather than on percentages of sequence identities (results not shown). Although the NY virus isolate showed its closest relationship to the Nebraska type strain of SBWMV, the nucleotide sequences of most of its coding regions analysed so far, with the exception of its gene for the cystein-rich protein, differed by 10% or more from those of the corresponding genome parts of the Nebraska type strain (Fig. 3). Much closer relationships between the two viruses became evident, however, when the amino acid sequences of the putative translation products were compared (Figs. 2 and 3). This is most striking with the coat protein amino acid sequences which are completely identical despite the fact their coding sequences differ in as many as 68 nucleotide positions. Very close relationships were also found in the partial amino acid sequences of the replicase and of the readthrough domain of the coat protein (Fig. 3).

Coding region

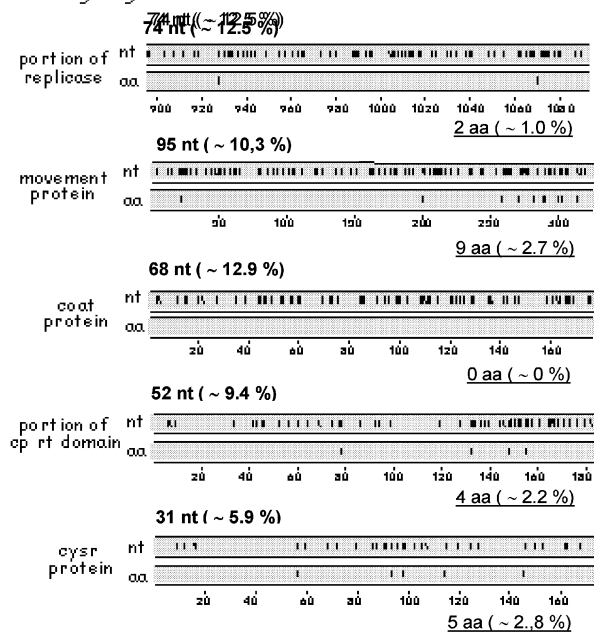

Fig. 3. Differences between the Nebraska type strain and the NY strain of SBWMV a) in the nucleotide sequences of various coding regions (labelled by 'nt' in the upper bars) and b) in the deduced amino acid sequences of the corresponding proteins (labelled by 'aa' in the lower bars). Positions where the nucleotides or amino acids, respectively, differ in the two virus strains are labelled by vertical lines in the bars. The scales show the position numbers of the amino acids in the proteins. The comparisons were generated by the GAPSHOW program of the UWGCG software. The number of nt changes (bold face) is given on the left side top of each block, the number of aa changes (underlined) on the right side bottom of each block. Modified from Koenig *et al.* (2002).

Additional comparisons were made with two other sources of SBWMV from the United States for which only partial sequences have been determined, i.e. an Oklahoma isolate (Chen *et al.*, 1995) and an Illinois isolate (Shirako, 1998). The nucleotide sequence of RNA 2 of the Oklahoma isolate is very similar to that of the Nebraska type strain. The nucleotide sequence of the coat protein gene and the 5' UTR of RNA 2 of an Illinois isolate, however, is almost identical to the analysed sequence of the NY virus source. There is only a single nucleotide exchange in the coat protein genes and this does not cause a change in the deduced amino acid sequences. The Illinois and the NY sources of SBWMV may, therefore, be closely related, at least in their RNAs 2. This may not necessarily be true for their RNAs 1, because for some furoviruses it has been shown that their RNAs 1 and 2 may occur in different combinations (Koenig and Huth, 2000).

The fact that there are many nucleotide changes in the available sequences of the closely related Nebraska and Oklahoma isolates on the one site and of the NY and the Illinois isolates on the other suggests that these viruses may have separated a long time ago. However, since most of these nucleotide changes are silent, there has presumably been a high selection pressure towards the conservation of the amino acid sequences. The trees shown in Fig. 2 for the furoviral movement and coat protein genes and their translation products and similar trees for the other genome parts which are not shown here clearly suggest that the NY virus isolate should be considered as a strain of SBWMV.

The genbank accession numbers for the sb3/UF9 and UF18/sb5 sequences on RNA 1 and the gsb63/sb40 and sb38/sb11 sequences on RNA 2 of the NY isolate of SBWMV described here are AY016007, AF361641, AY016008 and AF361642, respectively. A detailed description of this work has been given by Koenig *et al.* (2002).

Acknowledgement

We are greatly indebted the Deutsche Forschungsgemeinschaft (grants Ko518/13 and Ko518/14) for financially supporting part of this work.

References

- Chen J., MacFarlane S., and Wilson T.M.A. (1995). An analysis of spontaneous deletion sites in *soilborne wheat mosaic virus* RNA2. *Virology* 209, 213-217.
- Diao A., Chen J., Gitton F., Antoniw J.F., Mullins J., Hall A.M., and Adams A.M. (1999a). Sequences of *European wheat mosaic virus* and *oat golden stripe virus* and genome analysis of the genus furovirus. *Virology* 261, 331-339.
- Diao A., Chen J., Ye R., Zheng T., Yu. S, Antoniw J.F., and Adams M.J. (1999b). Complete sequence and genome properties of *Chinese wheat mosaic virus*, a new furovirus from China. *J. Gen. Virol.* 80, 1141-1145.
- Koenig R., and Huth W. (2000). *Soilborne rye mosaic* and *European wheat mosaic virus*: two names for a furovirus with variable genome properties which is widely distributed in cereal crops in Europe. *Arch. Virol.* 145, 689-697.
- Koenig R., Pleij C.W.A., and Huth W. (1999). Molecular characterization of a new furovirus mainly infecting rye. *Arch Virol.* 144, 2125-2140 .
- Koenig R., Bergstrom G.C., Gray S.M. and Loss S. (2002). A New York isolate of *Soilborne wheat mosaic virus* differs considerably from the Nebraska type strain in the nucleotide sequences of various coding regions but not in the deduced amino acid sequences. *Arch. Virol.* 147, 617-625.
- Miller N.R., Bergstrom G.C., and Gray S.M. (1991). Identity, prevalence, and distribution of viral diseases of winter wheat in New York in 1988 and 1989. *Plant Disease* 75: 1105-1109
- Shirako Y, (1998). Non-AUG translation initiation in a plant RNA virus: a forty amino-acid-acid extension is added to the N-terminus of *soilborne wheat mosaic virus* capsid protein. *J. Virol.* 72, 1677-1682.
- Shirako Y., Suzuki N., and French R, (2000). Similarity and divergence among viruses in the genus *Furovirus*. *Virology* 270, 201-207.
- Shirako Y, and Wilson TMA (1993). Complete nucleotide sequence and organization of the bipartite RNA genome of *soilborne wheat mosaic virus*. *Virology* 195, 16-32.

SINGLE AMINO ACID CHANGES IN THE 25 PROTEIN OF *BET* NECROTIC YELLOW VEIN VIRUS DETERMINE RESISTANCE RESPONSES OF *BETA VULGARIS* SPP. *MARITIMA*

S. Chiba, M. Miyanishi, H. Kondo and T. Tamada

Research Institute for Bioresources, Okayama University, Kurashiki, 710-0046, JAPAN

Summary

The resistance response to *Beet necrotic yellow vein virus* (BNYVV) can be evaluated on the basis of phenotypes in inoculated leaves of *Beta vulgaris* ssp. *maritima* differential lines MR5 and MR12 by manual inoculation: no visible or necrotic lesions (R phenotype) and blight yellow lesions (S phenotype). The resistant reaction induced no or only limited accumulation of the virus in inoculated leaves, whereas the susceptible reaction resulted in a high level of virus accumulation. These phenotypes were determined by the RNA3-encoded P25 of BNYVV and differed with BNYVV isolates, suggesting that there is a genotype specific resistance interaction between BNYVV strains and *B. maritima* hosts. Site-directed mutagenesis of the cDNA clones of BNYVV RNA3 (isolate O11) revealed that amino acid differences at position 68 in the P25 protein determined the avirulence function of virus resistance.

Introduction

Rhizomania disease caused by *Beet necrotic yellow vein virus* (BNYVV) is widely distributed in many sugar beet growing countries and is economically very important (Asher, 1993). Genetic resistance is the most promising approach for the control of the disease. A number of cultivars with varying degrees of resistance or tolerance to rhizomania have been developed and are presently grown in rhizomania-infested regions. Resistance to rhizomania in most commercial sugarbeet cultivars is controlled by the dominant allele *Rz* (Wisler, et al., 1999). The resistance of such cultivars has been reported to be caused by a restriction of virus multiplication and/or translocation in the roots (Scholten et al., 1994; Tamada et al., 1999a).

The genome of BNYVV usually consists of four RNA components. RNAs 1 and 2 encode proteins involved in replication, assembly and cell-to-cell movement, and RNAs 3 and 4 are needed for disease development and spread in nature (Tamada, 1999). We have shown that the 25 kDa protein (P25) encoded by RNA 3 is directly responsible for the development of rhizomania symptoms on susceptible sugarbeet cultivars, and also that it may inhibit virus translocation from rootlets to taproots in the resistant cultivar (Tamada et al., 1999a). In addition, we found that the resistance responses of plants to BNYVV were assessed by lesion types in inoculated leaves of *Beta vulgaris* ssp. *maritima* (*B. maritima*) by manual inoculation (Tamada et al., 1999b). Here we report evidence that amino acid residues at position 68 in the P25 protein of BNYVV play an important role in resistance responses.

Materials and Methods

Plant materials

Two resistant *B. maritima* lines MR5 and MR12 and one susceptible *B. maritima* line MR0 were used. MR5 and MR12 lines were selected from lines MR1 and MR2 lines, respectively (Tamada et al., 1999b). The sugarbeet cultivars Monomidori and Rizor were used as susceptible and resistant controls, respectively.

Virus isolates

The wild-type virus isolates O11 (Obihiro, Hokkaido), S113 (Sobetsu, Hokkaido) and GW

(Germany), which contain four RNA components, were used. The laboratory isolate O11-4, which lack RNA3, was obtained from original isolate O11 by single lesion transfers in *Tetragonia expansa* leaves, as described by Tamada et al. (1989). The wild-type and mutant viruses were propagated in inoculated leaves of *T. expansa*.

cDNA clones, infectious transcripts, and inoculation

DNA manipulations and cloning were carried out using standard procedures. Plasmid pT3O11, which contains a full-length cDNA insert of RNA3 of BNYVV- O11 under control of a bacteriophage T7 RNA polymerase promoter was used as a starting material for mutagenesis. PCR-based, site-directed mutagenesis was applied for generation of mutant constructs: four mutants, T3O11Y, T3O11H, T3O11C and T3O11A, which contained substituted Y(Tyr), H(His), C(Cys) and A (Ala), respectively, at position 68 (F, Phe) in pT3O11. Additional two mutants T3O11AAA and T3O11□FHG, which contained substituted AAA (three Ala) and deleted FHG, respectively, at positions 68 to 70 were constructed. In vitro transcripts from each of cDNA clones were co-inoculated onto *T. expansa* leaves with RNA of BNYVV-O11-4, which contained RNA1, RNA2 and RNA4. The extracts from infected leaves were inoculated to well-expanded leaves of test plants. BNYVV infection and virus content in inoculated leaves were determined by ELISA

Detection of virus and RNA

BNYVV infection and virus content in inoculated leaves were determined by ELISA.

Results and Discussion

Susceptible and resistance responses to BNYVV in sugarbeet cultivars

As shown in a previous paper (Tamada et al., 1999b), susceptible and resistance responses to BNYVV in sugarbeet plants could be assessed by mechanical inoculation. In susceptible sugarbeet cultivar Monomidori, BNYVV-O11 produced chlorotic and yellowish lesions in inoculated leaves at one week after inoculation, and in a few days they became bright yellow lesions. In resistant cultivar Rizor, however, BNYVV-O11 produced only small yellow or necrotic lesions in inoculated leaves. Sometimes, no visible lesions were produced. In contrast, BNYVV-GW produced bright yellow-type lesions in this resistant cultivar. ELISA tests showed that a high level of virus was in inoculated leaves showing yellow lesions, but no or only small amount of virus was detected in leaves showing small or necrotic lesions. Based on differences of phenotypes in inoculated leaves, bright large yellow lesions are referred to as a susceptible phenotype (S), whereas no visible, small or necrotic lesions are referred to as a resistant phenotype (R).

*Screening and reaction of *B. maritima* lines by BNYVV isolates*

To clarify the response to virus infection in resistant hosts, we screened three BNYVV isolates O11, S113 and GW on nine accessions of *B. maritima*, from which the resistant genes are derived (Geyl et al., 1995; Whitney, 1989). Two lines, designed MR1 and MR2, which originated from two accessions BGRC54778 and BGRC51424, respectively, were selected (Tamada et al., 1999b). Because a small number of plants in these progeny were susceptible to BNYVV-O11, homogeneous lines were obtained by further selection: designated lines MR5 (from MR1) and MR12 (from MR2). Our preliminary observations suggest that resistance to BNYVV in MR5 and MR12 lines may be controlled by a simple dominant gene.

As shown in Table 1, *B. maritima* line MR5 plants were resistant to BNYVV-O11, but susceptible to BNYVV-S113, whereas the line MR12 plants were resistant to BNYVV-O11 and BNYVV-S113. In sugarbeet cultivar Rizor, BNYVV-S113, as well as BNYVV-O11, induced the resistance reaction, suggesting that Rizor has a similar resistance property to the line MR12. BNYVV-GW showed susceptible phenotype in the two lines and Rizor. Thus, there were

genotype specific resistance interactions between BNYVV strains and *B. maritima* hosts. In other words, BNYVV-O11 is avirulent in *B. maritima* MR5 and MR12 plants, whereas BNYVV-GW is virulent in these plants.

Single amino acid substitutions in P25 protein determine the resistance phenotype

To identify the sequence or amino acids necessary for resistance phenotype, we constructed four mutants, which Phe at position 68 of P25 protein of BNYVV-O11 was replaced by Tyr, His, Cys and Ala, and one mutant, which three amino acid residues (Phe, His and Gly) at position 68 to 70 were replaced by Ala, Ala and Ala. All mutant transcripts were mixed with RNA of BNYVV-O11-4 and inoculated to *B. maritima* lines MR5, MR12 and MR0 and sugarbeet cultivar Monomidori and Rizor. No sequence reversions in the mutated amino acids were detected in the virus progeny.

In *B. maritima* line MR12 and cultivar Rizor, the Tyr-replaced mutant at position 68 showed the R phenotype, whereas Cys- and Ala- replaced mutants showed the S phenotype (Table 1). However, His-replaced mutant developed necrotic yellow symptoms, showing intermediate reaction between S and R phenotypes (Table 1). The AAA mutant showed the S phenotype in all plants tested. However, a mutant, in which three amino acid residues were deleted completely lost either pathogenicity or resistance (Table 1).

Table 1 Reaction of *Beta vulgaris* ssp. *maritima* lines and sugarbeet cultivar sap-inoculated with Beet necrotic yellow vein virus isolates and mutants derived from RNA3 cDNA constructs

BNYVV isolate	RNA3 transcript	Amino acid of P25			<i>B. maritima</i> lines			Sugar beet cultivar	
		68	69	70	MR5	MR12	MR0	Rizor	Monomidori
O11	—	F	H	G	R	R	S	R	S
S113	—	Y	R	V	S	R	S	R	S
GW	—	Y	H	R	S	S	S	S	S
O11-4	—				O	O	O	O	O
O11-4	T3O11F	F	H	G	R	R	S	R	S
O11-4	T3O11Y	Y	H	G	S	R	S	R	S
O11-4	T3O11H	H	H	G	S	I	S	I	S
O11-4	T3O11C	C	H	G	S	S	S	S	S
O11-4	T3O11A	A	H	G	S	S	S	S	S
O11-4	T3O11AAA	A	A	A	S	S	S	S	S
O11-4	T3O11?FHG	—	—	—	O	O	O	O	O

O11, GW and S113 : RNA 1+2+3+4, O11-4 : RNA 1 + 2 + 4

R : resistance phenotype (no or necrotic spots), S : susceptible phenotype (yellow spots),

I : intermediate phenotype (necrotic yellow spots), O : no resistant and susceptible reaction (chlorotic spots)

In conclusion, BNYVV P25 has a dual function: it is required for pathogenicity on susceptible beet plants and functions as an avirulence gene on resistant beet plants. Amino acid changes at position 68 in the P25 protein resulted in a loss of the avirulence function of virus resistance. Phenylalanine or Tyrosine at this position plays one of the key factors in determining resistance responses in *B. maritima* and its avirulence function loses by single amino acid changes in this position. This mechanism remains to be proved.

References

- Asher M. J. C. (1993). Rhizomania. *In: The Sugar Beet Crop: Science into Practice*. D. A. Cooke and R. K. Scott, eds. Chapman and Hall, London. pp. 311-346.
- Geyl L., Garcia Heriz M., Valentin P., Hehn A., and Merdinoglu D. (1995). Identification and characterization of resistance to rhizomania in an ecotype of *Beta vulgaris* subsp. *maritima*. *Plant Pathol.* 44: 819-828.
- Scholten O. E., Paul D., van Lent J. W. M., and Goldbach R. W. (1994). In situ localization of *beet necrotic yellow vein virus* (BNYVV) in rootlets of susceptible and resistant beet plants. *Arch. Virol.* 136: 349-361.
- Tamada T. (1999). Benyviruses. *In: Encyclopedia of Virology*. Second Edition. R. G. Webster and A. Granoff, eds. Academic Press, London. pp. 154-160.
- Tamada T., Shirako Y., Abe H., Saito M., Kiguchi T., and Harada T. (1989). Production and pathogenicity of isolates of *beet necrotic yellow vein virus* with different numbers of RNA components. *J. Gen. Virol.* 70: 3399-3409.
- Tamada, T., Uchino, H., Kusume, T., and Saito, M. (1999a). RNA 3 deletion mutants of *beet necrotic yellow vein virus* do not cause rhizomania disease in sugar beets. *Phytopathology* 89: 1000-1006.
- Tamada, T., Miyanishi, M., and Takemoto, M. (1999b). Involvement of *beet necrotic yellow vein virus* RNA 3 in restricted virus multiplication in resistant lines of *Beta vulgaris* ssp. *maritima*. *Proc. Symp. 4th Int. Working Group on Plant Viruses with Fungal Vectors* pp.127-130.
- Wisler, G. C., Lewellen, R. T., Sears, J. L., Liu, H. -Y., and Duffus, J. E. (1999). Specificity of TAS-ELISA for *beet necrotic yellow vein virus* and its application for determining rhizomania resistance in field-grown sugar beets. *Plant Disease* 83: 864-870.
- Whitney, E. D. (1989). Identification, distribution and testing for resistance to rhizomania. *Plant Disease* 73: 284-290.

SEQUENCES ANALYSIS OF BELGIAN BNYVV AND DEVELOPMENT OF A SIMULTANEOUS DETECTION OF SOILBORNE SUGAR-BEET VIRUSES BY RT-PCR

A. Meunier, J.-F. Schmit and C. Bragard

Unité de phytopathologie. Faculté d'ingénierie biologique, agronomique et environnementale, Croix du Sud, 2 bte 3. 1348 Louvain-la-Neuve, Belgium.

Summary

Sugar beets and soils suspected of being infected by rhizomania have been collected in more than one hundred locations in Belgium. Each sample was analyzed by DAS-ELISA and RT-PCR targeting BNYVV RNA-5 and the readthrough protein of RNA-2. BNYVV was detected by RT-PCR in more than 40% of the fields targeted. None of these isolates showed the presence of RNA-5. BNYVV RNA-3 of 27 Belgian isolates was sequenced from nt. 446 to nt.1000. Based on these results, B type was found mainly in the eastern areas of Belgium while A type was detected in the west. The identity at the nucleotide level between the isolates was 100% for the B type, 98.9% for the type A and 96.0% between the two types. Nine of the 11 mutations observed between the two types lead to amino acid changes. Amino acids of p25 protein of RNA-3 shows 100%, 97.2% and 94.6% of identity for the B type, the A type and between the two respectively. A multiplex RT-PCR detecting BNYVV, *Polymyxa betae* and *Beet soilborne virus* (BSBV) and *Beet virus Q* (BVQ) was developed to facilitate their detection. The technique revealed that the latter two are present in more than 80% of the fields tested as well as in Asian and European soils. The exact role of these pomoviruses in the disease of rhizomania is not yet clearly demonstrated though their simultaneous occurrence in sugar beets raises questions.

Introduction

SSCP and RFLP techniques (Koenig *et al.*, 1995) have been proposed for the differentiation of types within *Beet necrotic yellow vein virus* (BNYVV), responsible for the rhizomania disease. Three types have been detected : the type A is present in most of the countries, type B is found in France and Germany, and type P is found in Pithiviers (France) and Kazakhstan (Koenig *et al.*, 2000). Here we report the characterization of different types from Belgium by partial sequencing of BNYVV RNA-3 and the search for RNA-5. RNA-3 facilitates the multiplication and spread of BNYVV in roots and is associated with the development of symptoms and RNA-5 is associated with the severity of symptom development (Tamada *et al.*, 1999).

Since its discovery in 1984 in Belgium, rhizomania has spread. A multiplex RT-PCR was designed for the simultaneous detection of BNYVV with two other sugar Beet soilborne viruses, *Beet soilborne virus* (BSBV) and *the Beet virus Q* (BVQ), and their vector *Polymyxa betae*, as these were also previously described in Belgium (Stas *et al.*, 2001 ; Verhoyen *et al.*, 1987).

Material and Methods

Sugar beets and soils suspected to be infected by rhizomania have been collected in 106 different soils from Belgium and compared to different reference soils from different countries (Bulgaria, France, Germany, Hungary, Italy, Sweden, The Netherlands, Turkey). Sampling, RNA extraction and RT-PCR was described in Meunier *et al.* (2000).

The multiplex RT-PCR was performed under the same conditions as for RT-PCR described in Meunier *et al.* (2000) except otherwise stated. For RT reactions, 10 pmoles of the four reverse primers were used, representing of 0,5 µl of BNYVV2(1)rev, 0,5µl of BSBV2rev, 0,5µl of

BVQ1(1)rev, 0,5µl of PB4rev mixed with 1,2µl of RNA and 7,3 µl of DEPC treated water. The mixture was incubated at 65°C for 10 minutes and directly transferred into ice prior adding the RT reagents. For the PCR reaction, 18 pmoles of each primer (BNYVV2(1)for, BNYVV2(1)rev, BSBV2for, BSBV2rev, BVQ1(1)for BVQ1(1)rev, PB4for, PB4rev) were used (Meunier *et al.*, unpubl.). Amplification cycles were as follows : a first denaturation cycle of 3 minutes at 94°C, then 35 cycles composed of denaturation of 30 seconds at 94°C, annealing 30 seconds at 63°C and elongation 2 minutes at 72°C were carried out. A final elongation of 7 minutes at 72°C was added.

For sequencing, primer (4.5 pmoles) and 4 µl of "Dynamic ET terminator cycle sequencing (Amersham, England) were added to 200 to 300 ng of RT-PCR product. RT-PCR products were purified and directly sequenced on both strands using "ABI 377" sequencer. Multiple alignment of sequences was performed using "CLUSTAL W" (Higgins *et al.*, 1996) available on the belgian EMBnet server .

Results and Discussion

RT-PCR was performed on RNA extracted from sugar beet rootlets using primers (Kruse *et al.*, 1994) targeting RNA-3 and primers targeting RNA-2. 43% of the fields targeted showed the presence of BNYVV. Using the primers proposed by Kiguchi *et al.* (1996), there were no reactions indicating the presence of RNA-5 (Meunier *et al.*, 2000). Twenty seven soils were selected for analysis of BNYVV type by sequencing.

The presence of restriction sites described by Kruse *et al.* (1994) for BNYVV types by RFLP showed that Belgian isolates correspond to A and B types. Eight sequences from type A showed 98.9% of identity at the nucleotide level while 19 from type B show 100%. The identity between the two types is of 96.0%.

At the amino acid level, the identity is of 94,6%, 97.2% and 100% between the two types, within type A and B respectively. Eleven of the nucleotide mutations lead to amino acids changes when compared to European published sequences, but up to 25 if Japanese and Chinese sequences are taken into account.

There is no indication of a clear geographical distribution according to BNYVV type, but this is not surprising for such a small country having many sugar refineries like Belgium. Nevertheless, the type A can be divided into two sub-groups and were mainly found in the western regions of the country, including in the Polders region where rhizomania was first observed in the mid 80's in Belgium.

The variation between sequences are displayed in Fig. 1. As already stated (Koenig and Lennfors, 2000), it is clear that the type B is more different from type A and P. The mutations detected do not seem to be randomly distributed along the genome. Especially, there is a group of more than 8 mutations grouped between nucleotides 165-209.

The amplification of the three viruses and their vector using this method is presented in Fig. 2. The different bands obtained were extracted from the gel and subsequently sequenced to verify the specificity of the mRT-PCR. The technique was validated on a large series of RNA samples extracted from sugar-beet rootlets coming from different infected and non-infected fields from Belgium, Holland, France, Germany, Hungary and Italy (figure 3). The results obtained for the infected samples are consistent with previous results obtained by single RT-PCR or by ELISA.

nt. position	83	94	103	111	124	125	145	150	165	189	202	203	206	208	209	256	265	271	286	291	293	296	305	306	335	343	353	354	365	380	385	389	394	410	423	426	438	453	487	489	516	523	535	
Doel (5)	t	c	a	g	t	c	a	g	t	a	t	t	a	a	g	c	t	g	g	t	g	a	c	a	t	c	a	t	t	t	c	t	t	t	t	c	t	c	c	a	g	g	a	
Vinalmont	t	c	a	g	t	c	a	g	t	a	t	t	a	a	g	c	t	g	g	t	g	a	c	a	t	c	a	t	t	t	c	t	t	t	t	c	t	c	c	a	g	g	a	
Beclers	t	c	a	g	t	t	a	g	t	a	c	a	a	a	g	c	t	g	g	t	g	a	c	a	t	c	a	t	t	t	c	t	t	t	t	c	t	c	c	a	g	g	a	
S. M. Guill.	t	c	a	g	t	t	a	a	t	a	c	a	a	a	g	c	t	g	g	t	g	a	c	a	t	c	a	t	t	t	c	t	t	t	t	c	t	c	c	a	g	g	a	
Pithiviers	t	c	a	g	t	a	g	t	a	c	t	a	a	a	g	c	t	g	g	t	g	a	c	a	t	c	a	t	t	c	t	t	t	t	c	t	c	c	a	g	g	a		
Italy	t	c	a	g	t	a	g	t	a	c	t	a	a	a	g	c	t	g	a	c	g	a	c	a	t	c	a	t	t	c	t	t	c	t	t	c	t	c	c	a	g	g	a	
Mazy (20)	t	a	a	a	t	t	t	g	c	t	t	a	a	a	g	t	t	g	g	t	g	a	c	g	t	t	c	c	t	t	g	t	a	t	t	t	t	c	g	a	g	g	g	
Japan	t	c	g	g	t	t	a	g	t	a	t	a	a	g	t	c	t	g	g	t	g	a	c	a	a	t	c	a	t	c	a	t	a	t	t	t	t	t	t	t	a	g	g	a
China	g	c	a	g	t	t	a	g	t	a	t	a	a	a	g	c	t	a	g	t	a	g	a	a	a	a	a	t	a	t	c	a	a	a	a	c	t	a	t	a	c	a	a	

nt. position	83	94	103	111	124	125	145	150	165	189	202	203	206	208	209	256	265	271	286	291	293	296	305	306	335	343	353	354	365	380	385	389	394	410	423	426	438	453	487	489	516	523	535
Doel (5)	I	H	I	R	S	T	L	N	G	F	H	R	L	L	D	G	S	R	D	A	V	L	N	I	V	H	V	L	F	D	F	F	N	P	V	V	N						
Vinalmont	I	H	I	R	S	T	L	N	G	F	H	R	L	L	D	G	S	R	D	A	V	L	N	I	V	H	V	L	F	D	F	F	N	P	V	V	N						
Beclers	I	H	I	R	L	T	L	N	G	H	H	G	L	L	D	G	S	R	D	A	V	L	N	I	V	H	V	L	F	D	F	F	N	P	V	V	N						
S.M. Guill.	I	H	I	R	L	T	L	N	G	H	H	G	L	L	D	G	S	R	D	A	V	L	N	I	V	H	V	L	F	D	F	F	N	P	V	V	N						
Pithiviers	I	H	I	R	V	T	L	N	G	L	H	G	L	L	D	G	S	R	D	A	V	L	N	I	V	H	V	L	F	D	F	F	N	P	V	V	N						
Italy	I	H	I	R	L	T	L	N	G	L	H	G	L	L	D	G	S	R	D	A	V	L	N	I	V	H	V	L	F	D	F	F	N	P	V	V	N						
Mazy (20)	I	N	I	R	L	S	L	N	G	Y	H	R	L	L	D	G	S	R	D	A	V	L	T	I	V	D	V	I	F	D	F	F	N	P	V	V	D						
Japan	I	H	V	R	L	T	L	N	G	Y	R	V	L	L	D	G	S	R	D	A	V	L	N	T	V	N	V	I	F	D	F	F	N	S	V	I	N						
China	S	H	I	R	L	T	L	N	G	Y	H	G	L	L	N	G	S	H	G	E	D	L	N	I	A	N	D	I	Y	D	F	L	N	S	V	I	N						

Fig. 1. Nucleotide and amino acid sequence alignments, showing only the nts or aa in those positions allowing a differentiation between BNYVV sources from Belgium (type A : Doel, Beclers, Vinalmont ; type B : Mazy) compared to reference sequences from China (AJ239200), France (type P, AF197545), Italy (type B, AF197551) and Japan (type A : D84412). The position of the nucleotide is given in the first line (nt. 446-1000). Numbers between brackets represent the number of isolates with similar sequences in the group.

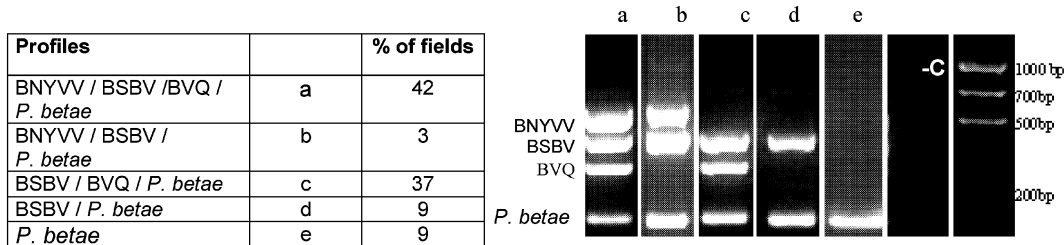

Fig. 2. Percentage of the different profiles observed in the tested fields (left) and mRT-PCR amplification profiles observed of mRT-PCR after electrophoresis on TBE agarose gel 1%. Letters indicate the different combinations observed, -C is a negative control.

Analyzing sugar-beet samples for the presence of BNYVV, BSBV, BVQ and *P. betae* individually is time consuming either by RT-PCR or even serological methods. RT-PCR is more sensitive than ELISA (Henry *et al.*, 1995). A mRT-PCR technique detecting BNYVV, BSBV, BVQ, *P. betae* was therefore developed. Losses of tap root weight of up to 40 %, and a reduction of sugar content up to 35 % have been reported under experimental conditions (Kaufmann *et al.*, 1993, Prillwitz and Schlösser, 1993), even if some authors consider that losses under field conditions symptoms are not obvious even with high BSBV content (Lindsten, 1993). Nevertheless, the potential role of the newly described species *Beet virus Q* (Koenig *et al.*, 1998) and the reason for the simultaneous occurrence of three different virus within sugar beets affected need to be documented.

Acknowledgements

Meunier A. is a fellow from the Belgian FRIA (Fonds pour la Recherche dans l'Industrie et l'Agriculture). Schmit JF. and Bragard C. are thankful to the Ministry of Small Enterprises, Traders and Agriculture / DG6 – Department “Research and Development” – Section “Subsidized Research”.

References

- Henry, C.M., Barker, I., Morris, J., Hugo, S.A. (1995). Detection of *Beet necrotic yellow vein virus* using reverse transcription and polymerase chain reaction. *Journal of Virological Methods* 54, 15-28
- Higgins, D.G., Thompson, J.D. and Gibson, T.J. (1996). Using CLUSTAL for multiple sequence alignments. *Methods Enzymol.* 266, 383-402.
- Kiguchi, T., Saito, M., Tamada, T. (1996). Nucleotide sequence analysis of RNA-5 of five isolates of *Beet necrotic yellow vein virus* and the identity of a deletion mutant. *Journal of General Virology* 77: 575-580.
- Koenig, R. and Lennfors, L. (2000). Molecular analyses of European A, B and P type sources of *Beet necrotic yellow vein virus* and detection of the rare P type in Kazakhstan. *Archives of Virology* 145, 1561-1570.
- Koenig, R., Luddecke, P., Haeberlé, A.M. (1995). Detection of *Beet necrotic yellow vein virus* strains, variants and mixed infections by examining single-strand conformation polymorphisms of immunocapture RT-PCR products. *Journal of General Virology* 76, 2051-2055.
- Koenig, R., Pleij, C.W.A., Beier, C., Commandeur, U. (1998). Genome properties of *Beet virus* Q, a new furo-like virus from sugar beet, determined from purified virus. *J. Gen. Virol.* 79: 2027-2036
- Kruse, M., Koenig, R., Hoffman, A., Kaufmann, A., Commandeur, U., Solovey, A.G., Savenkov, I., Burgmeister, W. (1994). Restriction fragment length polymorphism analysis of reverse transcription-PCR products reveals the existence of two major strain groups of *Beet necrotic yellow vein virus*. *Journal of General Virology* 75, 1835-1842.
- Lesemann, D.E., Koenig, R., Lindsten, K. and Henry, C. (1989). Serotypes of *Beet soilborne furovirus* from FRG and Sweden. *Bulletin OEPP* 19: 539-540
- Lindsten, K. (1993). Rhizomania – are both *Beet necrotic yellow vein virus* (BNYVV) and *Beet soilborne virus* (BSBV) involved? In : *Proceedings of the 2nd Symposium of the IWGPV/FV, Montreal, Canada, 1993*, 67-70
- Meunier, A., Schmit, J-F., Stas, A., Marlier, A., Wauters, A., Steyer, S., Bragard, C. (2000). The status of Rhizomania in Belgium. *Parasitica* 56(2-3),85-97.
- Prillwitz, H. and Schlösser, E. (1993). Interactions between *Beet soilborne virus* (BSBV-2) and *Beet necrotic yellow vein virus* (BNYVV). In : *Proceedings of the 2nd Symposium of the IWGPV/FV, Montreal, Canada*, 67-70
- Stas, A., Meunier, A., Schmit, J.F., Bragard, C. (2001). First report of *Beet virus* Q in Belgium. *Plant disease* 85, 1288.
- Tamada, T., Uchino, H., Kusume, T. and Saito, M. (1999). RNA-3 deletion mutants of *Beet necrotic yellow vein virus* do not cause rhizomania disease in sugar beets. *Phytopathology* 89, 1000-1006.
- Verhoyen, M., Van Den Bossche, M., Van Steyvoort, L. (1987). Identification de nouveaux virus de la betterave en Belgique. *Revue Agric.* 40, 1463.

PATHOGENICITY AND MOLECULAR VARIABILITY OF *BEET NECROTIC YELLOW VEIN VIRUS* ISOLATES FROM EUROPE, JAPAN, CHINA AND THE UNITED STATES

T. Tamada, M. Miyanishi, H. Kondo, H. Chiba, and C. G. Han,

Research Institute for Bioresources, Okayama University, Kurashiki, 710-0046 Japan

Summary

The sequence variability of *Beet necrotic yellow vein virus* (BNYVV) was analyzed in 59 isolates collected from the world. Based on RNA3 sequence differences, BNYVV isolates fell into eight clusters, which were clearly associated with geographical origins except for some Chinese isolates. Each type of clusters we designated the following country-region: Japan-Date, Japan-Obihiro, Japan-Tsubetsu, China-Hohhot, China-Xinjiang, France-Pithiviers, Italy and Germany. The Italy cluster contained isolates from Italy, France, Slovakia, Hungary, Spain, Turkey, the USA and China, and the Germany cluster contained isolates from Germany, France and China. Isolates belonging to the other clusters seemed to be restricted in respectively named regions. Most isolates in five clusters contained RNA5. There were differences among clusters or among isolates of one cluster in pathogenicity in differential lines of *Beta vulgaris* spp *maritima*.

Introduction

Beet necrotic yellow vein virus (BNYVV) was first found in Italy during the 1950s, in Po plain and Adige valley (Canova, 1959). From 1971 to 1990, it was observed in an increasing number of countries, from central and southern Europe to eastern and northern Europe and Middle East Asia (Asher, 1993; Tamada, 1999). In Japan, the virus was first found in 1965. In China, BNYVV was first found in 1978 and in the USA in 1983. Thus, rhizomania disease is recently distributed in many sugarbeet growing regions of the world.

The genome of BNYVV usually consists of four RNA components: RNA1 and RNA2 are required for viral RNA replication, assembly, virus movement and transmission, whereas RNA3 and RNA4 are needed for disease development and spread in nature (Richards and Tamada, 1992). However, some BNYVV isolates from Japan, France and China contain RNA5, which is associated with the severity of symptom development in sugarbeet roots (Tamada, 1999). The majority of BNYVV isolates may be classified into two major groups, types A and B (Kruse et al., 1994). The A type is found in most European countries, USA, China and Japan, whereas the B type is detected in Germany and France. The nucleotide sequences of A and B types were about 97% identical when averaged over all four RNAs (Saito et al., 1996). As a step towards understanding the evolution and route of spread of BNYVV, here we have examined the sequence variation of RNA3-encoding P25 protein and the coat protein genes of BNYVV isolates collected from the world, and their pathogenicity using differential lines of *Beta vulgaris* spp *maritima*.

Materials and Methods

Virus sources

All BNYVV isolates used were derived from infested soil samples which were collected from Japan (Hokkaido), Italy, France, Germany, Slovakia, Hungary, Spain, Turkey, the USA and China (Table 1). For virus isolation, sugarbeet seedlings were grown in special test tubes which contained a mixture of quartz sand and each soil sample. After growth for 3 to 5 weeks, virus infection in roots was tested by ELISA. Sap of the virus-infected rootlets was inoculated to

Tetragonia expansa leaves, in which each virus isolate was propagated and used as sequence materials or as inoculum for pathogenicity tests.

Table 1. Origins of BNYVV isolates used in this study

Country	No. of isolates	Name of isolates
Japan	17	S, T101, S110, R83, S113, K80, M87, SH1, O11, S12, S42, K58, N64, S44, T41, T16, H45
Italy	12	IV1, IM2, IF3, IV4, IP5, IP6, IP7, I18, I30, I62, I67, I81
France	6	FP, FC, F13, FA, FB, FH
Germany	4	GW, GI, GA, GM
Slovakia	2	SLN1, SLP2
Hungary	4	HUM1, HUK3, HUT4, HUA5
Spain	1	SPC
Turkey	1	TUK
USA	4	USC, USTF, USTH, USM
China	8	CH2, CH3, CY1, CHa, CX1, CX3, CX5, CX6

RT-PCR cloning and nucleotide sequencing

For sequencing of the P25 coding region of RNA3 and the coat protein region of RNA 2, total nucleic acids were extracted by direct phenol methods from inoculated leaves of *T. expansa*. For RNA3, two specific primers 3F (5'-AGTTGTTGT GTTTTCTGATC-3', nt 408 TO427) and 3R (5'-CCACAGGATCACGTGTAGTT -3', complementary to nt 1267 to 1248) were used. For the coat protein region of RNA 2, three specific primers 2F (5'-CGAGTAATAAGTAGCCGCCGTC-3', nt 103 to 124), 2R (5'-CAAAGGAAGACCATGTG AGGA-3', complementary to nt 916 to 937) and 2C (5'-ACCCCGTTCCATTATACCC-3', complementary to nt 2289 to 2308) were used. PCR products were ligated into a pGEM-T vector (Promega) and transformed into *Escherichia coli* strain XL1-Blue. The nucleotide sequences of selected clones were determined with an Applied Biosystems 377 DNA sequencer (Perkin Elmer). Multiple alignments of nucleotide sequences were obtained using CLUSTAL W.

Pathogenicity tests

Pathogenicity of BNYVV isolates was assessed by phenotypes which appeared on inoculated leaves of three differential hosts: two resistant *Beta vulgaris* spp *maritima* lines MR5 (or MR1) and MR12 (or MR2) and one susceptible line MR0 (Tamada et al., 1999).

Results

Variation of RNA3 sequences in BNYVV isolates

Nucleotide sequences for the RNA3-encoded P25 protein of 59 BNYVV isolates were determined and deduced amino acid sequences were compared with each other. The P25 proteins in all isolates consist of 219 amino acid residues, and there was a maximum of 4.3% sequence variation (17 amino acid changes) at the nucleotide level when each isolate was compared. Fig. 1 shows the neighbor-joining tree calculated from the percent nucleotide differences of the P25 coding region (657 nucleotides). The RNA3 variants fell into eight clusters, which were clearly associated with geographical origins except for some Chinese isolates. Therefore, each type of clusters we designated the following country-region (representative isolate): Japan-Date (S113), Japan-Obihiro (O11), France-Pithiviers (FP), Italy (IP6), Japan-Tsubetsu (T41), China-Hohhot (CH2), China-Xinjiang (CX5) and Germany (GW). The Japan-Date cluster contains six Japanese isolates, the Japan-Obihiro cluster contains seven Japanese isolates, and the France-Pithiviers cluster contains two French isolates. These three clusters were closely related to each other, and were designated as group 1. The isolates belonging to the Japan-Obihiro cluster were widely distributed throughout Hokkaido, but

distribution of isolates of Japan-Date and France-Pithiviers clusters were limited. The China-Hohhot cluster contains three Chinese isolates, the Japan-Tsubetsu cluster contains three Japanese isolates, and the Italy cluster contains twelve Italian, four Hungarian, two Slovak, two French, one Turkish, one Spanish, two Chinese, and four US isolates. These three clusters were closely related to each other, and were designated as group 2. Isolates of the Japan-Tsubetsu cluster were detected in limited areas, but those of Italy cluster seemed to be widely distributed throughout the world. The Germany cluster contains four German, two French and one Chinese isolates and were designated as group 3. The phylogenetic tree shows that RNA3 sequences of groups 1 and 2 are more closely related to each other than to those of group 3. This grouping corresponds well to the A type and B type in the classification of Kuruse et al. (1994), although there are some exceptions for Chinese isolates. However, the cluster China-Xinjiang containing two Chinese isolates was placed between the A type and B type.

RNA5 was detected from most isolates belonging to five clusters Japan-Date, Japan-Obihiro, France-Pithiviers, China-Hohhot and China-Xinjiang, but not from isolates grouped in clusters Japan-Tsubetsu, Italy or Germany.

Comparison of the coat protein gene

The coat protein genes of five clusters Japan-Date, Japan-Obihiro (except two isolates), Japan-Tsubetsu, China-Xinjiang and Italy were completely identical. These isolates all belonged to the A type. France-Pithiviers isolates were included in the A type, although their coat protein genes differed from them at two positions (Miyaniishi et al., 1999). All isolates from Germany were identified as B type. The coat protein genes for S12 and S44 isolates (Japan-Obihiro) and CH2 and CH3 isolates (China-Hohhot) were similar to those of the B type, although RNA3 variants of these isolates belonged to the A type (Fig. 1).

Pathogenicity of BNYVV isolates

Representative isolates in different clusters were examined by mechanical inoculation to three *B. maritima* differential lines MR5 (or MR1) and MR12 (or MR2) and MR0. The isolate O11 (Japan-Obihiro) showed the resistance phenotype in MR5 and MR12 plants, whereas

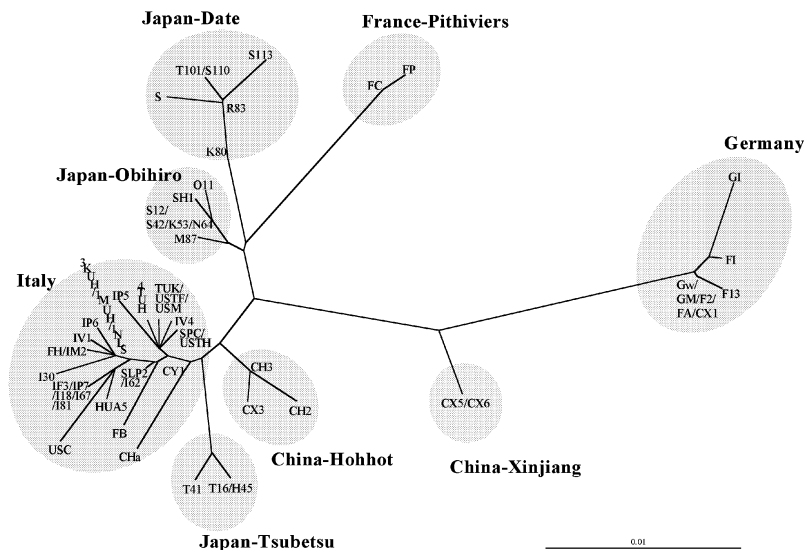

Fig. 1. Phylogenetic tree obtained from RNA3 nucleotide sequence alignment in BNYVV isolates using CLASTRU W. The scale bars represent the number of nucleotide replacements per site.

isolates S113 (Japan-Date) and FP (France-Pithiviers) showed the resistance phenotype in MR12 plants, but susceptible phenotype in MR5 plants. The other isolates (Japan-Tsubetsu, China-Hohhot, China-Xinjiang and Germany) showed the susceptible phenotype in both lines. However, phenotypes of isolates grouped in the Italy cluster were different, depending on single amino acid substitutions in the P25 protein. MR0 plants were susceptible to all isolates tested.

Discussion

The nature and geographic location of BNYVV variants not only illustrates the evolution of BNYVV genomes but also the possible route of its spread to various regions. It is only in the last 30 years that BNYVV has developed into a serious problem in many sugarbeet growing regions of the world. Here we present evidence for the existence of eight clusters of RNA3 variants, which were clearly associated with geographical origin. We would speculate that two types, A and B, were separated from an original population of BNYVV for long time ago, and thereafter, the A type virus branched into two variants, one of which accompanied with RNA5, and then each of these two variant separated further into three variants. At least three variants might have been introduced into Japan and have consequently spread from a single or a few locations. On the other hand, one variant, Italian original virus has been widely spread throughout the world. In these processes, higher positive selection was taking place in RNA3-encoded P25 protein, resulting in several amino acid changes or recombination between the genomes. Such a selection pressure may be affected by some environmental changes such as cultivation of resistant cultivars, because there were differences among clusters in pathogenicity in accessions of *B. maritima*.

Acknowledgements

We are grateful to Drs. M. Fattori, R. Resca, J. Horvath, V. Subikova, F. Ertunc, E. De Bruyne, and C. M. Rush for kindly providing with BNYVV samples.

References

- Asher, M. J. C. (1993). Rhizomania. *In: The Sugar Beet Crop: Science into Practice*. D. A. Cooke and R. K. Scott, eds. Chapman and Hall, London. pp. 311-346.
- Canova, A. (1959). Appunti di patologie della barbabietola. *Informatore Fitoopatologico* 9:390-396.
- Kruse, M., Koenig, R., Hoffmann, A., Kaufmann, A., Commandeur, U., Solovyev, A. G., Savenkov, I. and Burgermeister, W. (1994). Restriction fragment length polymorphism analysis of reverse transcription-PCR products reveals the existence of two major strain groups of *Beet necrotic yellow vein virus*. *J. Gen. Virol.* 75: 1835-1842.
- Miyanishi, M., Kusume, T., Saito, M. and Tamada, T. (1999). Evidence for three groups of sequence variants of *Beet necrotic yellow vein virus* RNA 5. *Arch. Virol.* 144: 879-892.
- Richards, K.E. and Tamada, T. (1992). Mapping functions on the multipartite genome of *Beet necrotic yellow vein virus*. *Annu. Rev. Phytopath.* 30: 291-313.
- Saito, M., Kiguchi, T., Kusume, T. and Tamada, T. (1996). Complete nucleotide sequence of the Japanese isolate S of *Beet necrotic yellow vein virus* RNA and comparison with European isolates. *Arch. Virol.* 141: 2163-2175.
- Tamada, T. (1999). Benyviruses. *In: Encyclopedia of Virology*. Second Edition. R. G. Webster and A. Granoff, eds. Academic Press, London. pp. 154-160.
- Tamada, T., Miyanishi, M., and Takemoto, M. (1999). Involvement of *Beet necrotic yellow vein virus* RNA 3 in restricted virus multiplication in resistant lines of *Beta vulgaris* ssp. *maritima*. *Proc. Symp. 4th Int. Working Group on Plant Viruses with Fungal Vectors* pp.127-130.

MUTATION OF PRO-73 IN THE ARM REGION OF THE *CUCUMBER NECROSIS VIRUS* COAT PROTEIN RESULTS IN PARTICLES WITH AN ALTERED SWOLLEN CONFORMATION AND LOSS OF FUNGUS TRANSMISSIBILITY

K. Kakani¹ and D'A. Rochon²

¹Faculty of Agricultural Sciences, University of British Columbia, Vancouver, B.C, V6T1Z4 and
²Agriculture and Agri-Food Canada, PARC, Summerland, B.C. V0H 1Z0

Summary

Soil transmission of *Cucumber necrosis virus* (WT CNV) occurs via zoospores of *Oligidium bornovanus*. Previous work from our lab has demonstrated that the virus quasi three-fold axis contains determinants for virus attachment to zoospores. In the present work we wanted to assess if other regions of coat protein are also important in transmission. Proline 73, predicted to be involved in arm exchange in the virus particle interior, was mutated to glycine (CPM). Interestingly, CPM particles were not transmitted by zoospores, despite the fact that they are infectious and accumulate well in plants. Agarose gel electrophoresis of native CPM and WT CNV showed identical mobilities, however, swollen virus particles had distinct mobilities and trypsin and chymotrypsin digestions of native and swollen CPM yielded distinct banding patterns following SDS/PAGE. Thus, it appears that both native and swollen CPM have different conformations than WT CNV. *In vitro* zoospore binding studies showed that swollen WT CNV binds more efficiently than native WT CNV, and similarly, that swollen CPM binds more efficiently than native CPM. Together, these results suggest that the swollen conformation of WT CNV may be important in the transmission process and that the low transmissibility of CPM may be due to its inability to form the proper swollen conformation.

Introduction

CNV, a member of the *Tombusvirus* genus, is naturally transmitted by zoospores of the root-inhabiting fungus *O. bornovanus*. During transmission, CNV binds to zoospores in the soil and bound virus enters roots upon zoospore encystment. We have recently shown that a cavity in the vicinity of the CNV coat protein trimer plays an important role in attachment of virus to zoospores during the transmission process (Kakani et al., 2001). The CNV particle is an icosahedron consisting of 180 identical coat protein subunits. Each subunit folds into three distinct domains: an inward facing RNA binding domain (R), the shell (S) and an outward facing protruding domain (P) (Fig. 1). The R and S domains are connected by a 34 amino acid arm (a) and the S and P domains by a 5 amino acid hinge (h). The coat protein trimer consists of three conformationally distinct subunits, A, B and C. In the C subunit, the arm is ordered and in the A and B subunits it is disordered. The C subunit arm interdigitates with two other C subunit arms on the particle 3-fold axis to form an internal scaffold called the β -annulus which determines the curvature of the particle during assembly. Two conserved proline residues in the tombusvirus arm (Fig. 1) have been proposed to play an important role in virus assembly (Bergdoll et al., 1997). Pro-73 is located where the arms come out from the C-subunit to form the B annulus and is proposed to be involved in arm exchange. Pro-85 controls the position of the arm relative to the rest of the subunit and is proposed to be involved in regulation of quasi-equivalence.

Tombusviruses are known to expand in size by about 10% when particles are treated with EDTA at high pH (Robinson and Harrison, 1982). Structural studies of the expanded particle show that the trimer interface is the portion of the capsid that is most affected during expansion. In the expanded state, negatively charged aspartate residues between adjacent trimer subunits repel each other resulting in the appearance of an 80 Å long and 20 Å wide opening at the

center of the trimer. In this state, the intersubunit opening is sufficiently large for the arms to come out from the virus, making the arms susceptible to proteolytic cleavage (Robinson and Harrison, 1982).

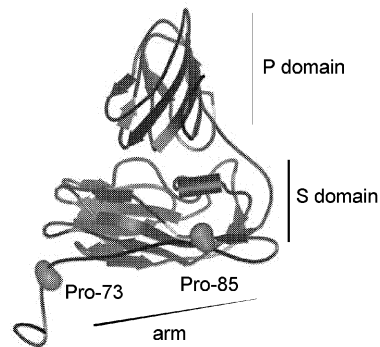

Figure 1. Structure of the CNV CP subunit. Locations of the protruding (P) and shell (S) domains are indicated. The arm region (a) is shown along with the positions of Pro-73 and Pro-85.

Recent work in our laboratory has shown that specific residues in the shell and protruding domains of the CNV capsid play important roles in transmission possibly through their contribution to features of the trimer cavity, a proposed zoospore binding site (Kakani *et al.*, 2001). In this study, we wished to examine if the arm region, particularly, residues Pro-73 and Pro-85, also play a role in transmission.

Materials and Methods

Transmission assays were conducted as previously described (Kakani *et al.*, 2001). Mutations were produced in infectious CNV cDNA clones using primer mutagenesis. Virus was swollen by adjusting the virus solution to pH 8.0 and by adding EDTA to a final concentration of 20-200 mM. Binding assays were as described by Rochon *et al.*, 2002 (this proceedings issue).

Results

A panel of CNV mutants with mutations in either Pro-73 or Pro-85 were prepared. Table 1 lists the mutants and indicates whether or not virus particles are produced and the relative virus yield. Of the five mutants, only mutant CPM, which contains a Gly substitution at Pro-73 and mutant CPA, which contains an Ala substitution at Pro-73 produced particles. Virus particle production in *N. benthamiana* by CPM was similar to that of WT virus whereas virus production by CPA was very poor (approximately 5% of WT CNV).

Mutant	Mutation	Virus particles	Virus Yield
CPM	Pro-73 to Gly	yes	Equal to WT CNV
CPM2	Pro-85 to Gly	no	-
CPA	Pro-73 to Ala	yes	Poor
CPC	Pro-73 to Cys	no	-
CPL	Pro-73 to Leu	no	-

Fungus transmission assays were conducted using purified CPM particles. CPM only transmitted in 1 of 20 inoculated pots whereas WT CNV transmitted in 20 of 20 inoculated pots. Further infectivity experiments using mechanical inoculation were conducted to assess the relative fitness levels of WT CNV and CPM. In these experiments, CPM had a dilution endpoint similar to that of WT CNV (approximately 5-20 picograms of virus/leaf) (data not shown) and produced similar symptoms on cucumber. CPM only accumulated to about 60% of WT CNV in cucumber, but it is unlikely that this slightly lower accumulation level accounts for the drastic reduction in fungus transmission.

Since Pro-73 is believed to play an important role in virus structure and assembly, we wanted to assess if CPM has an altered native or swollen conformation, and if so, if the altered conformation might be responsible for the loss of transmissibility.

Fig. 2 shows an agarose gel of native and swollen CPM and WT CNV. Native CPM comigrates with native WT CNV, however, the swollen forms of CPM and WT CNV have distinct migrations, suggesting that the swollen state of CPM is different from that of WT CNV. To further investigate this possibility, swollen CPM and WT CNV were incubated with low amounts of trypsin and chymotrypsin. Fig. 3 shows that the proteolytic digestion pattern of swollen CPM differs from that of WT CNV. Trypsin digested swollen WT CNV yields primarily two protein species of approximately 24- and 20-kDa, whereas that of CPM yields primarily the smaller 20-kDa protein. Similarly, chymotrypsin digested WT CNV yields two major proteins of about 26- and 22-kDa, whereas digestion of CPM gives rise to the 22-kDa species, but not the 26-kDa species, and also produces a 17-kDa species which is not observed in CNV digestions. Also, it is noted native CPM is susceptible to trypsin and chymotrypsin cleavage whereas native WT CNV

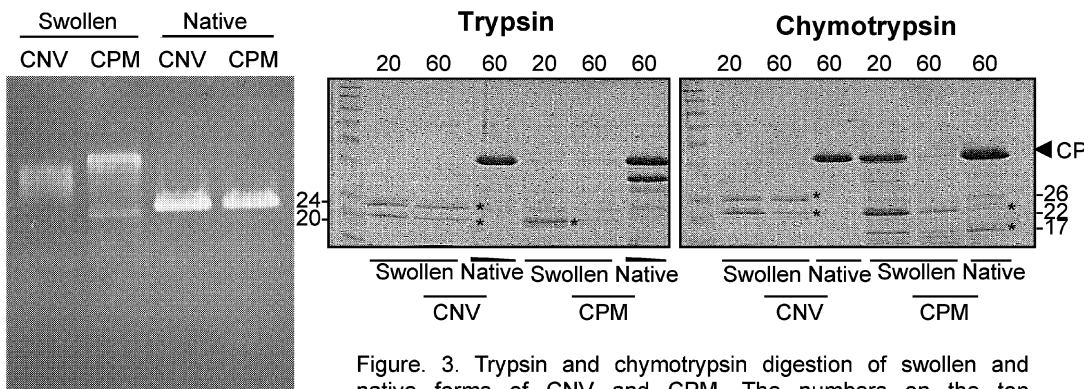

Figure 2. Agarose gel electrophoresis of swollen and native forms of CNV and CPM. Virus was electrophoresed through a 1% agarose gel and stained with ethidium bromide.

Figure 3. Trypsin and chymotrypsin digestion of swollen and native forms of CNV and CPM. The numbers on the top correspond to the time in minutes used for each digestion. The numbers on the left and right correspond to the sizes in kDa of digestion products of trypsin and chymotrypsin treatments, respectively. CP indicates the position of undigested coat protein. The asterisks highlight the positions of digestion products.

is not. These data support the conclusion that the native and swollen forms of CPM are structurally distinct from those of WT CNV.

The notable difference in the swollen conformation of CPM along with its inability to be transmitted prompted us to investigate the potential role of the swollen conformation in the transmission process. Results of parallel transmission tests showed that native CPM transmitted in 1 of 5 inoculated pots whereas swollen CPM transmitted in 4 of 5 inoculated pots (data not shown). Similar experiments, conducted with the native and swollen forms of WT CNV, showed that swollen WT CNV also transmits more efficiently than native WT CNV. In this case the number of pots that were infected following inoculation were similar (5 of 5), however, the ELISA values for pots inoculated with the swollen form were two-fold higher, indicating that more sites on roots were infected. Further experiments where we reduce inoculum concentration or the number of zoospores will help to establish the apparent higher transmission frequency of swollen WT CNV.

Previous work has shown that several CNV transmission mutants show reduced zoospore binding in *in vitro* assays. An *in vitro* microplate binding assay was conducted (see Rochon et al., 2002; this proceedings issue) to determine the relative zoospore binding efficiencies of the

native and swollen forms of WT CNV and CPM. Fig. 4 shows that the swollen forms of WT CNV and CPM both bind zoospores much more efficiently than the native forms with swollen WT CNV binding about 14 times more than native WT CNV and swollen CPM binding about 35 times more than native CPM. These results are consistent with the results of our transmission assays and, moreover, point to the possibility that the swollen form of WT CNV plays an important role in the transmission process. In addition, the results show that both the native and swollen forms of WT CNV bind zoospores much more efficiently than the native and swollen forms of CPM (5.7 times and 2.4 times, respectively). These results also mirror the transmission results and suggest that the altered conformation of native and/or swollen CPM affects transmissibility.

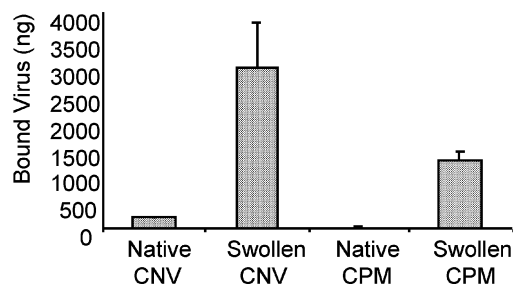

Figure 4. Binding of swollen and native forms of CNV and CPM to zoospores using a microtiter plate assay (ELBA). Binding is shown as ng CNV bound per 2.5×10^6 zoospores.

In conclusion, the data in this manuscript support the notion that the swollen form of CNV plays a role in the transmission process. The increased transmission and binding efficiency of CPM following swelling, reinforces the importance of swelling in the transmission process. However, the fact that CPM fails to achieve the high binding and transmission efficiencies of WT CNV even after swelling, points to aberrant swelling of CPM as a factor.

Previous studies have suggested that the swelling of spherical viruses known to occur *in vitro* may play a role in uncoating within infected host cells, *in vivo* (Robinson and Harrison, 1982). The results described here suggest a role for swelling in the transmission process. Poliovirus is known to undergo a conformational change similar to swelling during attachment to its cellular receptor (Fricks and Hogle, 1990). We propose that CNV may undergo a similar change during attachment to putative zoospore receptors and that the increased transmission and binding efficiencies that we observe upon *in vitro* swelling of CNV facilitate the subsequent stages of the zoospore attachment process.

References

- Bergdoll, M., Remy, M. H., Cagnon, C., Masson, J. M. and Dumas, P. (1997). Proline dependent oligomerization with arm exchange. *Structure* 5:391-401.
- Campbell, R.N. (1996) Fungal transmission of plant viruses. *Annu. Rev. Phytopath* 34, 87-108.
- Fricks, C. E. and Hogle, J. M. (1990). Cell-induced conformational change in poliovirus: Externalization of the amino terminus of VP1 is responsible for liposome binding. *J. Virol.* 64:1934-1945.
- Kakani, K., Sgro, J. Y. and Rochon, D. (2001) Identification of *Cucumber necrosis virus* coat protein amino acids affecting fungus transmission and zoospore attachment. *J. Virol.* 75, 5576-5583
- Olson, A. J., Bricogne, G. and Harrison, S. C. (1983). Structure of *Tomato bushy stunt virus* IV. *J. Mol. Biol.* 171:61-93.
- Robinson, I. K. and Harrison, S. C. (1982). Structure of expanded state of *Tomato bushy stunt virus*. *Nature.* 297:563-568.

ANALYSIS OF RNA1 OF *LETTUCE BIG-VEIN VIRUS*, GENUS *VARICOSAVIRUS* REVEALS ITS RELATION TO RHABDOVIRUSES

T. Sasaya¹, K. Ishikawa¹ and H. Koganezawa²

¹National Agricultural Research Center for Western Region, Zentsuji, Kagawa 765-8508, Japan and ²National Agricultural Research Center for Western Region, Fukuyama, Hiroshima 721-8514, Japan

Summary

Lettuce big-vein virus (LBVV) is a type member of the genus *Varicosavirus*. LBVV particles contain two species of single-stranded RNA, RNA1 and RNA2. The complete nucleotide sequence of RNA1 from LBVV was determined. LBVV RNA1 consists of 6797 nucleotides and one large ORF that encodes a protein with 2040 amino acids. Database searches showed that the predicted protein resembled the polymerases of mononegaviruses, nonsegmented negative-sense RNA viruses, especially rhabdoviruses. The alignment revealed that the functional domains were conserved in the polymerases among LBVV and mononegaviruses. phylogenetic analyses of the polymerases between LBVV and mononegaviruses also suggest that LBVV is more closely related to rhabdoviruses than other mononegaviruses. Transcription termination/polyadenylation signal-like poly(U) tracts that resemble those in mononegavirus RNAs were present upstream and downstream of the coding region.

Introduction

Lettuce big-vein virus (LBVV) was first reported in 1983 as a probable causative agent of lettuce big-vein (Kuwata *et al.*, 1983). However, the fact that LBVV is a causative agent of the disease came under question after the second virus; *Mirafiori lettuce virus* was recently isolated from lettuce with big-vein symptoms (Lot *et al.*, 2002; Roggero *et al.*, 2000). LBVV has labile, rod-shaped particles about 320 to 350 × 18nm with a coat protein (CP) of 48 kDa. LBVV particles have been reported to contain two ds-RNAs (Kuwata *et al.*, 1983). LBVV is transmitted by the obligate parasitic soil-inhabiting fungus *Olpidium brassicae* (Lot *et al.*, 2002). LBVV was designated a type virus in an unassigned genus *Varicosavirus* in the 7th Report of the International Committee on Taxonomy of Viruses (Mayo *et al.*, 2000).

Although LBVV has been believed to be the cause of the economically important disease for nearly two decades, molecular characterization of LBVV has been slow because of difficulties in obtaining a sufficient amount of the purified virions. However, we succeeded in purifying LBVV virions from LBVV-infected lettuce plants and demonstrated that LBVV particles contain two ss-RNAs. Furthermore, one of the ss-RNA, RNA2 harbors the CP gene and has a negative-sense nature (Sasaya *et al.*, 2001). In this paper, we report the complete nucleotide sequence of another ss-RNA, RNA1, and present evidence that the polymerase of LBVV resembles most closely those of rhabdovirus, even though LBVV has a two-segmented RNA genome and its particles are not enveloped.

Materials and Methods

LBVV was purified as described by Sasaya *et al.* (2001). Viral RNAs were extracted from the purified virus preparation by SDS-phenol methods. The RNAs were then electrophoresed through 1% nondenaturing agarose gel. Ribonuclease A treatment utilizing high- and low-salt buffers was used to differentiate ss-RNAs and ds-RNAs. The riboprobes of the partial LBVV

polymerase gene were prepared using RNA Labeling Kit (Amersham-Pharmacia). Northern blot hybridization was carried out according to the standard protocols.

The RNA1 was purified by separation on a low melting temperature-agarose gel. The PCR-based cDNA library of the LBVV RNA1 was constructed as described by Froussard (1992). Since the LBVV RNAs preparation contained positive- and negative-sense RNAs, both ends of the LBVV RNA1 were determined by a 5'RACE system and verified by the 3'RACE on the 3' polyadenylated LBVV RNAs.

The amino acid sequence of the LBVV polymerase was compared with those of mononegaviruses. Abbreviations and GenBank accession numbers of viruses used for the comparison of amino acid sequences are: *Borna disease virus* (BDV), U04608; *Zaire ebola virus* (ZEBOV), AF272001; *Sendai virus* (SeV), AB039658; *Vesicular stomatitis indiana virus* (VSIV), J02428; *Rabies virus* (RABV), M13215; *Bovine ephemeral fever virus* (BEFV), AF234533; *Infectious haematopoietic necrosis virus* (IHNV), L40883; *Northern cereal mosaic virus* (NCMV), AB030277; *Sonchus yellow net virus* (SYNV), L32603; and *Rice yellow stunt virus* (RYSV), AB011257. Alignment of the polymerases was generated by the program CLUSTAL W. The cluster dendrogram was generated by the neighbor-joining method and the pairwise distances between the sequences were calculated using the MEGA version 2 software.

Results and Discussion

Two species of RNAs (ss-RNA1 and ss-RNA2) were observed in nondenaturing gels following electrophoresis of nucleic acids extracted from purified LBVV virions (Fig. 1 (a)).

Ss-RNA1 and ss-RNA2 were shown to be single-stranded by their susceptibility to digestion by RNase A both at high and low salt concentration and resistance to digestion by DNase I (data not shown). The estimated sizes of ss-RNA1 and ss-RNA2 were approximately 7.5 kb and 6.6 kb under nondenaturing conditions, respectively. Analysis of the same LBVV RNA preparations after denaturation by heat (94 °C, 3min) and then annealing at room temperature showed two additional species (ds-RNA1 and ds-RNA2) that were resistant to RNase A in high salt concentration, indicating that the two additional species of RNA were double-stranded. To confirm the location of the LBVV polymerase gene and the relationships among these four RNA species, the LBVV RNA preparations after denaturation by heat and then annealing at room temperature were analyzed by Northern blot hybridization analysis using negative- and positive-sense riboprobes of the LBVV polymerase gene (Fig. 1(b)). Not only ss-RNA1 but also ds-RNA1 hybridized to a positive-sense riboprobe. In contrast only ds-RNA1 hybridized to a negative-sense riboprobe. These results indicate that the LBVV polymerase gene is located in ss-RNA1, and that the ds-RNA1 is the double stranded form of ss-RNA1.

The LBVV RNA1 consists of 6797 nucleotides (accession number AB075039) and contains one large ORF in the viral complementary RNA, which starts at an AUG codon at position 339-341 and ends at an UGA codon at position 6459-6461. The predicted protein encoded by the ORF comprised 2040 amino acids with an estimated molecular weight 232,092. FASTA searches using the deduced amino acid sequence consistently retrieved the polymerases of

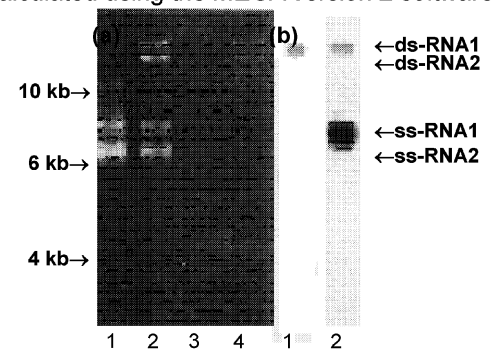

Fig. 1. (a) Analysis by agarose gel electrophoresis of LBVV RNAs. Lane 1 shows LBVV RNAs prepared from purified LBVV virions. Lane 2 shows the LBVV RNAs after heat-denaturation followed by annealing at room temperature. Lanes 3 and 4 show the effect of RNase A treatment in high salt concentration of the RNAs in lanes 1 and 2, respectively. (b) Northern blot hybridization with riboprobes of the partial LBVV polymerase gene. Lanes 1 and 2 were hybridization with negative - and positive - sense riboprobes, respectively. Single-strand RNA size markers (kb) are indicated on the left.

	Motif A	Motif B	Motif C	Motif D
LBVV	590 NINID FSK WNTNMR <54>	GHLGG F EGLRQKGWTVATVCLL <12>	LMGQ G DNQII <64>	LDGRQLPQWYKKT
NCMV	566 CINMD F EKWNLNMR <56>	GHIRG F EGLRQKGWTVFTVLI <12>	LMGQ G DNQVL <64>	YKGVPLCSSLKRI
VSIV	605 ANHID Y EKWNHQR <56>	GQEGG L EGLRQKWTILNLLVI <12>	VLAQ G DNQVI <63>	FRGVIRGLETKRW
RABV	618 AFHLD Y EKWNHQR <58>	GQDGG L EGLRQKGSLSLLMI <12>	VLAQ G DNQVL <63>	FRGNILVPESKRW
ZEBOV	632 SFVTD L EKYNLAFR <57>	GHMGG I EGLQKLWTSISCAQI <12>	SAVM G DNQCI <60>	LNGVQLPQSLKTA
SeV	663 FLTTD L KKYCLNWR <57>	NPRGG I EGYCQKLWTLISISAI <12>	AMVQ G DNQAI <60>	YDGKILPQCLKAL
BDV	447 VINLD Y SSWCNGFR <54>	GTKTMGEGMRQKLWTLTSCWE <12>	ILGQ G DNQTI <51>	FRGVPVPGCLKQL

Fig. 2. Alignment of conserved motifs of the polymerase of LBVV, three rhabdoviruses (NCMV, VSIV and RABV), one filovirus (ZEBOV), one paramyxovirus (SeV), and one bornavirus (BDV) within the order *Mononegavirales*. Numbers at the beginning of the lines indicate the position of the first displayed amino acid. Numbers within the brackets indicate the numbers of amino acids not represented in the figure. Conserved residues recognized previously for nonsegmented negative strand RNA virus polymerases (Tordo, *et al.*, 1992; Müller *et al.*, 1994) are shown in bold letters.

mononegaviruses, especially rhabdoviruses. The core region of the predicted protein of LBVV was aligned with polymerase of rhabdoviruses and representatives of other genera in the order *Mononegavirales* (Fig. 2). The alignment revealed the conservation of functional domains of RNA-dependent RNA polymerases (Poch *et al.*, 1989; Poch *et al.*, 1990; Müller *et al.*, 1994). The protein contained four motifs that correspond to the motifs A, B, C and D of block III (Poch *et al.*, 1989; Poch *et al.*, 1990; Müller *et al.*, 1994). A GDN at position 696 to 698 in motif C, and amino acids G at position 662 and W at position 671 in motif B, specific to mononegaviruses (Tordo *et al.*, 1992) were conserved. Other conserved motifs such as GHP motif in block I and a motif Kx₁₆₋₂₁GxGxG in block VI were also present.

The cluster dendrogram derived from alignments of the polymerase with LBVV and rhabdoviruses shows that the LBVV polymerase clustered with the polymerases of plant rhabdoviruses, and indicates that the polymerase of LBVV is more closely related to the polymerases of plant rhabdoviruses (genera *Cytorhabdovirus* and *Nucleorhabdovirus*) than to those of other rhabdoviruses (Fig. 3).

The 3' and 5' non-coding sequences of the RNA1 of LBVV is 338 and 336 nucleotides in length, respectively. The both end sequences of RNA1 had a high A + U content, similar to those of the 3'-leader and 5'-trailer sequences of mononegaviruses (Heaton *et al.*, 1989). Although complementarity between the 3' and 5' ends sequences is a common feature of the genomes of negative-sense RNA viruses, the complementarity between the extreme 3' and 5' ends of the LBVV RNA 1 was low. Downstream from the large ORF, a stretch of six uridine residues (poly(U)-tract), which resembles transcription termination/polyadenylation signals of mononegaviruses (Heaton *et al.*, 1989), was identified at positions 6541 to 6546. A similar poly(U)-tract was also identified at position 275 to 281 in the 3' non-coding region of LBVV

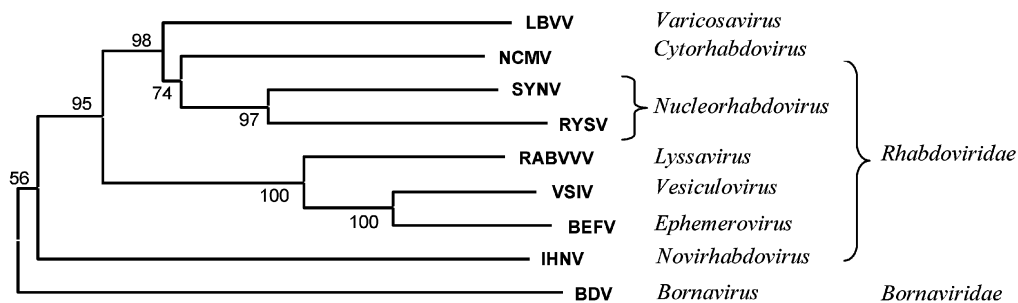

Fig. 3. Phylogenetic relationship between LBVV, seven rhabdoviruses (NCMV, SYN, RYSV, RABV, VSIV, BEFV and IHN) and one bornavirus (BDV). The phylogenetic tree was constructed based upon a CLUSTAL W multiple alignment of conserved region between the GHP motif and the motif D of the polymerase using the BLOSUM weighting matrix. The figures on the branches represent the percentage of trees containing each cluster out of 1000 bootstrap replicates. The branch lengths are proportional to the genetic distances between sequences.

RNA1 and at the end of the LBVV CP gene on the LBVV RNA2 (Sasaya *et al.*, 2001).

The virion structure of rhabdovirus is completely different from that of LBVV. The rhabdovirus has bullet-type or bacilliform structure and is enveloped, while LBVV is rod-shaped and has no envelope. Their vectors are also different essentially. However, present and previous data (Sasaya *et al.*, 2001) showed that amino acid sequences of coat protein and RNA polymerase of LBVV are homologous to corresponding proteins of rhabdovirus. Similar relationships are observed between the plant viruses in the genus *Tenuivirus* and the vertebrate viruses in the genus *Phlebovirus* of the family *Bunyaviridae*. The phleboviruses have envelopes, while tenuivirus virion is not enveloped. However, they share common properties in several respects (Falk and Tsai, 1998). It is tempting to speculate that tenuivirus and varicosavirus conserved the envelope proteins to other functional proteins, for example, adapting themselves to plant hosts and/or vectors.

References

- Falk, B. W. and Tsai, H. (1998). Biology and molecular biology of viruses in the genus *Tenuivirus*. *Ann. Rev. Phytopathol.* 36, 139-163.
- Froussard, P. (1992). A random-PCR method (rPCR) to construct whole cDNA library from low amounts of RNA. *Nucleic Acid. Res.* 20, 2900
- Heaton, L. A., Hillman, B. I., Hunter, B. G., Zuidema, D., and Jackson, A. O. (1989). Physical map of the genome of *Sonchus yellow net virus*, a plant rhabdovirus with six genes and conserved gene junction sequences. *Proc. Natl. Acad. Sci. USA* 86, 8665-8668.
- Kuwata, S., Kubo, S., Yamashita, S., and Doi, Y. (1983). Rod-shaped particles, a probable entity of *Lettuce big vein virus*. *Ann. Phytopathol. Soc. Jpn.* 49, 246-251
- Lot, H., Campbell, R. N., Souche, S., Milne, R. G., and Roggero, P. (2002). Transmission by *Olipidium brassicae* of *Mirafiori lettuce virus* and *Lettuce big-vein virus*, and their roles in lettuce big-vein etiology. *Phytopathology* 92, 288-293.
- Mayo, M. A. (2000). Genus *Varicosavirus*. In "Virus Taxonomy, Seventh Report of the International Committee on Taxonomy of Viruses" (M. H. V. van Regenmortel, C. M. Fauquet, D. H. L. Bishop, E. B. Carstens, M. K. Estes, S. M. Lemon, J. Maniloff, M. A. Mayo, D. J. McGeoch, C. R. Pringle, and R. B. Wickner, Eds), pp. 521-523. Academic Press, San Diego.
- Müller, R., Poch, O., Delarue, M., Bishop, D. H. L., and Bouloy, M. (1994). Rift valley fever virus L segment: correction of the sequence and possible functional role of newly identified regions conserved in RNA-dependent polymerases. *J. Gen. Virol.* 75, 1345-1352.
- Poch, O., Blumberg, B. M., Bougueleret, L., and Tordo, N. (1990). Sequence comparison of five polymerases (L proteins) of unsegmented negative-strand RNA viruses: theoretical assignment of functional domains. *J. Gen. Virol.* 71, 1153-1162.
- Poch, O., Sauvaget, I., Delarue, M., and Tordo, N. (1989). Identification of four conserved motifs among the RNA-dependent polymerase encoding elements. *EMBO J.* 8, 3867-3874.
- Roggero, P., Ciuffo, M., Vaira, A. M., Accotto, G. P., Masenga, V., and Milne R. G. (2000). An *Ophiovirus* isolated from lettuce with big-vein symptoms. *Arch. Virol.* 145, 2629-2642.
- Sasaya, T., Ishikawa, K., and Koganezawa, H. (2001). Nucleotide sequence of the coat protein gene of *Lettuce big-vein virus*. *J. Gen. Virol.* 82, 1509-1515.
- Tordo, N., de Haan, P., Goldbach, R., and Poch, O. (1992). Evolution of negative-stranded RNA genomes. *Semin. Virol.* 3, 341-357.

A DATABASE AND WEB SITE FOR PLANT VIRUS SEQUENCE ANALYSIS

M. J. Adams¹ and J. F. Antoniw²

¹Plant Pathogen Interactions Division and ²Scientific Systems and Bioinformatics Group, Rothamsted Research, Harpenden, Herts AL5 2JQ, UK

Summary

A database has been established that contains details of all sequences of viruses, viroids and satellites of plants, fungi and protozoa, classified by their current name. For all complete sequences and those that contain at least one complete gene, the start and end positions of each feature (genes, non-translated regions etc) are recorded and checked for accuracy. As far as possible, nomenclature for genes and proteins are standardised within genera and families. The database is updated for new sequences regularly and has been placed on a web site. A pilot application for analysis of codon use has been developed and some results are presented. We hope to add other types of analysis (e.g. multiple comparisons, primer design, secondary structure predictions) and welcome collaboration to help develop particular types of analysis.

Descriptions of Plant Viruses (DPV) on CD-ROM

In 1998, the Association of Applied Biologists (AAB) published the Descriptions of Plant Viruses on CD-ROM (Adams et al., 1998). This software (for PCs running Windows 3.1 or later) included in electronic form all 354 virus and group descriptions originally issued by the AAB in booklet form and a set of new virus descriptions. Descriptions were written by selected experts and edited by a team based at the Scottish Crop Research Institute. It also included taxonomic, genomic and sequence information based on the Plant Virus Notebook which was first demonstrated in prototype form at the 3rd IWGPV Symposium (Antoniw et al., 1996). We designed and created the database and other software to provide a package that contained complete and up-to-date taxonomic, genomic and sequence information for all plant viruses, viroids and satellites. This included lists of all available sequences for each virus which was checked to ensure that the correct current name was allocated to each sequence. Selected sequences of plant viruses, viroids and satellites were provided with the program and these could be displayed as interactive feature maps which facilitated the extraction of sequence features (e.g. coat proteins) for analysis. This was done by writing enhanced feature tables (EFT) for each sequence and the two files were used together in a separate DPVMap program. Any of the features from the map could be dragged into an editing box to display their nucleotide sequence (as RNA or DNA), or the predicted amino acid sequence of an open reading frame. Annotations provided for the correct display of reverse complementary sequences and of those incorporating a frameshift or intron. Since then, further descriptions have been added (to 389) and we have greatly increased the number of sequences provided, so that the program now includes all complete sequences and those that contain at least one complete gene. We now also include viruses of fungi and protozoa and there are also representative sequences for each completely sequenced animal virus in families with plant-infecting members (*Reoviridae*, *Rhabdoviridae*, *Bunyaviridae*) and of all other positive sense ssRNA animal virus genera. Sequence features are checked for accuracy and, as far as possible, nomenclature for genes and proteins are standardised within genera and families. In total, about 4900 sequences are now provided. Updates for users of the CD have been made available for downloading from the DPV web site. The program is being used enthusiastically in laboratories throughout the world, but with the greatly increased quantity of information, updating is now a rather unwieldy task.

DPV Web

Although we hope to continue supporting the PC version, we have now begun to provide the DPV databases on a dedicated web site (<http://www.dpvweb.net/>). The AAB, who sponsor the site, has agreed that the taxonomic and sequence data will remain freely available to all users. We expect to provide virtually all the facilities of the standalone version and in addition to develop a comprehensive facility for sequence analysis. At the time of writing, the site includes the virus descriptions and a pilot program for sequence analysis which is the subject of the current paper.

Sequence database and codon use analysis

The information contained in the individual EFT files has been transferred into a table of the DPV database which therefore contains the start and end positions of all significant features and genes in all plant virus sequences. A second table contains the nucleotide sequences from the standard EMBL/GenBank/DDBJ files. Linking these to the other tables in our database, we now have a powerful resource for many types of comparative analysis and we have developed a pilot application for analysis of codon use and bias. At present, this uses a stand alone program VirusCodon (written in Delphi) that is downloaded onto the user's PC but we are also developing a Java Webstart application that will operate seamlessly on all platforms from the web site.

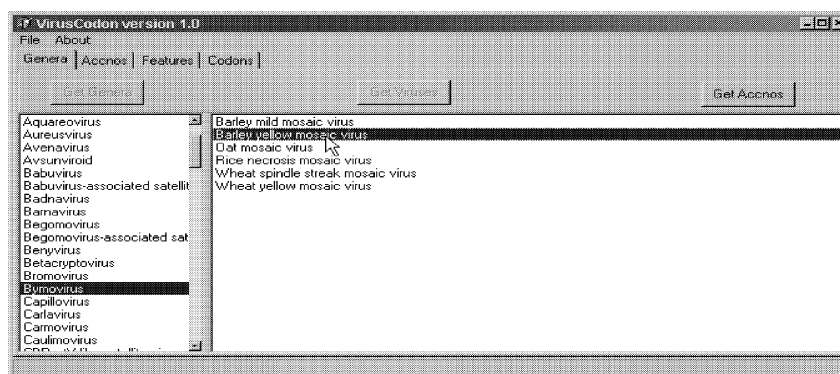

Fig. 1. Screenshot from the VirusCodon program showing the selection of a virus from the genus *Bymovirus*.

VirusCodon contains a series of pages that can be used to help select the sequences and features for analysis.

- **Genera:** This page is used to select the virus for analysis. A genus is selected in the left hand column and the Get Viruses button used to display the members (Fig. 1). One of these is selected by highlighting and submitted to the Accession page using the GetAccnos button.
- **Accnos:** This page lists all the available accessions of the virus previously selected with a brief description of each. One or more sequences are chosen and submitted to the Features page.
- **Features:** This page lists all the features detected in the sequences selected and one or more can be chosen and submitted for codon analysis (Fig. 2).

- **Codons:** This page provides the output, showing the numbers of each of the 64 possible codons and also the fraction for each codon within its synonymous family in a similar format to that of Codonfrequency in the GCG package (Genetics Computer Group, 2001). It also calculates the total number of codons, the GC content, the GC content of the third position in the codon and the Effective Number of Codons used (ENC), which is a simple overall measure of bias in synonymous codon use (Wright, 1990). This is done for each feature

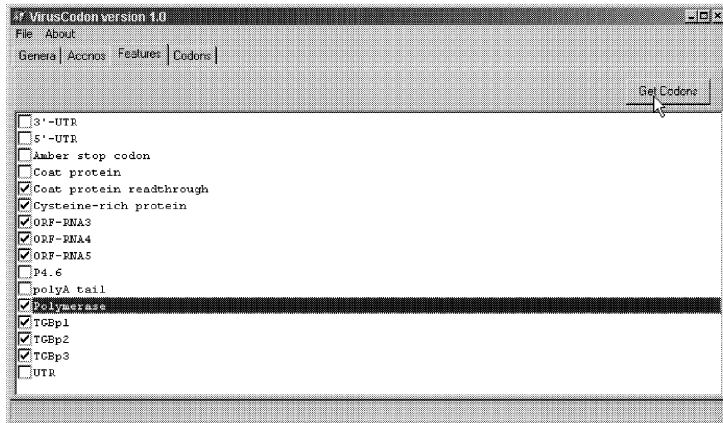

Fig. 2. Screenshot from the VirusCodon program showing selection of features from sequences of *Beet necrotic yellow vein virus*.

separately and for all features combined. The output can be copied and pasted into any Windows™ application for further processing.

Codon bias in fungally-transmitted viruses

Codon use has not been extensively studied in plant viruses and there are no reports exploring the possible relationships between codon statistics and the relative

abundance of the tRNAs in the host plant, the taxonomic position of the virus or the gene function. Understanding codon use is also potentially important in many molecular studies because natural or intro-duced differences between virus sequences might be classified as "silent" (because they do not affect the predicted amino acid sequence of the protein) but could have profound effects on gene expression if a commonly-used codon was substituted with one that was rarely-used.

Table 1. Effective Number of Codons (ENC) and GC content of third codon position for the complete coding sequences of all of the fully-sequenced viruses transmitted by fungi, arranged in increasing GC content.

Virus	ENC (range)	GC 3 rd	Virus	ENC (range)	GC 3 rd
BNYVV	45.6 (49.7-40.2)	32.0	CWMV	52.7 (53.0-45.5)	45.0
BSBMV	44.6 (59.9-41.9)	35.6	TNV-Sat	56.2 (56.2-56.2)	45.2
BVQ	53.0 (55.3-50.5)	38.4	SBWMV-J	51.9 (54.2-50.1)	45.7
BSBV	52.2 (55.0-49.6)	38.5	TNV-D	55.8 (56.2-51.6)	47.4
PMTV	51.5 (55.4-49.4)	41.9	OGSV	51.8 (55.8-51.2)	47.4
PCV	52.5 (58.5-50.8)	42.2	SrCSV	53.3 (53.4-52.2)	47.8
MNSV	55.0 (55.5-47.4)	43.5	OMV	55.4 (60.7-55.1)	49.2
IPCV	50.8 (67.2-49.0)	44.0	CuNV	58.8 (62.4-57.3)	50.0
SBWMV	50.9 (52.7-47.3)	44.3	WYMV	53.9 (53.9-53.4)	51.4
SBCMV	51.2 (50.6-40.3)	44.8	TNV-A	58.9 (59.3-57.1)	52.9
BaYMV	55.5 (55.3-55.3)	44.8	BaMMV	54.0 (54.9-53.5)	55.0

nucleotides in the genome and in particular to the GC content of the third codon position. This was not related to the taxonomic classification of the virus. The smallest GC content was found in the genomes of the sugar-beet infecting viruses but when data from other viruses (not transmitted by fungi) were examined, it was clear that viruses infecting a particular host plant varied greatly in their GC content (data not shown). There were interesting differences in the

Examples of some ENC data obtained from the fungally transmitted viruses are shown in Table 1. The ENC statistic varies from an extreme of 20, where only one codon is used for each amino acid to 61 when synonymous codons are used with equal frequency. There were usually few differences between genes of the same virus and the differences between viruses were related to the proportions of the four

patterns of individual amino acid codon usage, an example of which is shown for the furoviruses in Table 2, which demonstrates that the use of nucleotides in the third codon position is not consistent between different amino acids and is only partially related to their frequency in the genome as a whole.

Table 2. Frequencies of codons used for four amino acids in the genomes of the genus *Furovirus*. The numbers observed (O) are compared with those expected (E) if the third position base reflected its frequency (P) in the whole virus genome.

Base in 3 rd position	P	Gly (GGx)		Ala (GCx)		Thr (ACx)		Val (GTx)	
		O	E	O	E	O	E	O	E
G	27%	301	560	576	649	584	597	1039	775
A	28%	404	585	517	679	419	624	387	810
T	28%	1084	581	1068	673	947	619	1108	804
C	17%	291	354	251	411	269	378	345	490

Development

VirusCodon is intended primarily to demonstrate the usefulness of the databases. There is clearly the potential to use similar selection protocols and then provide different types of analyses either by locally provided software or by directing the output to other web-based analytical software. Some examples of analyses that could be provided are:

- Two-way comparisons between all the selected sequences
- Multiple sequence alignments and identification of common motifs
- Analysis of the nucleotide context of partially-suppressed stop codons or any other feature
- Design of PCR primers specific for a given taxonomic group of plant viruses
- BLAST searches amongst some, or all, of the plant virus sequences
- Protein prediction analyses for α -helices, β -sheets, transmembrane regions, antigenic sites or proteolytic cleavage sites

In order to develop these analyses in the most appropriate ways, we will welcome the opportunity to collaborate with researchers interested in particular types of analysis. We shall also welcome suggestions for improvement, to provide a central resource for plant virus taxonomic and genomic information and analysis.

We thank P. Jones (Rothamsted) and Drs H. Barker, A. T. Jones, A. F. Murrant and D. J. Robinson (Scottish Crop Research Institute, Dundee, Scotland) for their collaboration and suggestions and the Association of Applied Biologists for their support for the project. IACR receives grant-aided support from the Biotechnology and Biological Sciences Research Council of the United Kingdom.

References

- Adams M. J., Antoniw J. F., Barker H., Jones A. T., Murrant A. F. and Robinson D. (1998). Descriptions of Plant Viruses on CD-ROM. Wellesbourne, Warwick, UK: Association of Applied Biologists.
- Antoniw J. F., Cartwright, E. J. and Adams M. J. (1996). A Plant Virus Notebook for IBM-compatible computers. *Proc. 3rd Symp. Int. Working Group on Plant Viruses with Fungal Vectors*, Ed. J. Sherwood, pp. 189-192. Denver: American Society of Sugar Beet Technologists.
- Genetics Computer Group (2001). Wisconsin Package version 10.1. 575 Science Drive, Madison, Wisconsin 53711, USA.
- Wright, F. (1990). The 'effective number of codons' used in a gene. *Gene* 87, 23-29.

DEVELOPMENT OF DIAGNOSTICS FOR THE DETECTION AND QUANTIFICATION OF *OLPIDIUM BRASSICAE*.

L. Nott, J. Bambridge and J.A. Walsh

Horticulture Research International, Wellesbourne, Warwick, CV35 9EF, UK.

Summary

In order to avoid planting lettuce crops in areas infested with *Olpidium brassicae*, diagnostic tests are being developed for the detection and quantification of this fungus. Attempts are being made to produce a panel of monoclonal antibodies to *O. brassicae* zoospores. A second approach to develop a PCR-based test using primers that specifically amplify the ITS regions of *O. brassicae* is also being taken. We have collected a number of isolates of *O. brassicae* and *O. bornovanus* from different host plants and different countries and have sequenced and compared the ITS regions of some of these isolates. Primers have been designed to specifically amplify lettuce-infecting *O. brassicae* DNA. These have the potential to discriminate these isolates from other isolates that do not infect lettuce and from other fungi. The host ranges of the *O. brassicae* and *O. bornovanus* isolates are also being investigated, especially in respect of whether they infect lettuce.

Introduction

Olpidium brassicae is a member of the Chytridiomycetes and is a soilborne obligate zoosporic fungal parasite of plant roots. It has an important role as the vector of a number of plant viruses. It is the vector of the ophiovirus (Lot *et al.*, 2002) and varicosavirus (Huijberts *et al.*, 1990) associated with lettuce big-vein disease, the causal agent of *Lettuce ring necrosis* (Campbell and Lot, 1996) and a number of other plant viruses (Campbell, 1996). Lettuce big-vein disease is one of the most serious virus diseases of leafy vegetables in Europe. The main symptoms of the disease are vein-banding accompanied by crinkling and distortion of leaves. It can prevent or delay head formation, decrease head size and reduce the proportion of harvestable heads (Ryder, 1980). Control of the disease is virtually impossible once *O. brassicae* is established in lettuce fields, the resting spores can persist in soil for up to 22 years and retain the ability to transmit big-vein for up to 20 years (Campbell, 1985). Attempts to eradicate *O. brassicae* by soil sterilisation have proven mostly ineffective. We are attempting to develop diagnostics that will allow reliable detection and quantification of *O. brassicae* isolates capable of infecting different host plant species.

Materials and Methods

Lettuce plants were grown hydroponically in trays of nutrient solution and were inoculated with *O. brassicae* resting spores when they were three weeks old. When infection of the lettuce roots was established (usually four weeks after inoculation), the plants were harvested and left in plastic bags for 4-5 days at 4°C. Zoospores were extracted into a sucrose glycine solution (5g Sucrose, 1.9g Glycine/500ml distilled water) and concentrated by centrifugation (10 minutes at 500g). Harvested zoospores were used fresh as antigen for monoclonal antibody production, or the DNA was extracted, using the Qiagen Dneasy Plant mini DNA extraction kit, for the development of a DNA-based test to distinguish between *O. brassicae* isolates.

Results

Improvements were made in obtaining large quantities of clean zoospores by inoculating lettuce plants at a young age and growing them in nutrient solution rather than sand. Currently, cell lines are being screened for monoclonal antibodies to *O. brassicae* zoospores. Sequencing of the ITS1 region of several *O. brassicae* isolates and one *O. bornovanus* isolate has revealed large differences between brassica-infecting isolates and lettuce-infecting isolates. It has also shown that the *O. bornovanus* isolate from cucumber has a greater similarity to the lettuce-specific isolates than the brassica-specific isolates. This difference in the ITS1 region of brassica-specific isolates and lettuce-specific isolates has been utilised in the design of PCR primers that will specifically amplify only lettuce isolates. Experiments to test the specificity of these primers is underway.

Discussion

If sensitive and specific detection of *O. brassicae* can be achieved, then soil samples from lettuce fields, or the roots from bait plants grown in such samples, can be tested for the presence and quantity of *O. brassicae*. Eventually this should allow the risk of losses from big-vein to be predicted, so that growers can avoid planting in to fields where such risk is high.

References

- Huijberts, N., Blystad, D.-R., Bos, L. *Lettuce big-vein virus: mechanical transmission and relationships to Tobacco stunt virus. Ann. Appl. Biol.* 116, 463-475, 1990.
- Campbell, R.N. Longevity of *Olpidium brassicae* in air-dry soil and the persistence of the lettuce big-vein agent. *Can. J. Bot.* 63, 2288-2289, 1985.
- Campbell, R.N. Fungal transmission of plant viruses. *Annu. Rev. Phytopathol.* 34, 87-108, 1996.
- Campbell, R.N., Lot, H. *Lettuce ring necrosis, a virus-like disease of lettuce: evidence of transmission by Olpidium brassicae. Plant Disease* 80, 611-615, 1996.
- Lot, H., Campbell, R.N., Souche, S., Milne, R.G., Roggero, P. Transmission by *Olpidium brassicae* of *Mirafiori lettuce virus* *Lettuce big-vein virus* and their roles in lettuce big-vein etiology. *Phytopathology* 92, 288-293, 2002.
- Ryder, E. J. (1980). Studies on source and nature of big-vein resistance in lettuce and progress in breeding resistant cultivars. Proceedings of Eucarpia Meeting on Leafy Vegetables, Littlehampton, UK, 78-85.

THE DEVELOPMENT OF A QUANTITATIVE REAL-TIME PCR ASSAY FOR *SPONGOSPORA SUBTERRANEA* F.SP. *SUBTERRANEA* AND ITS USE IN EPIDEMIOLOGICAL STUDIES.

A.K. Lees, P. van de Graaf, D.W.Cullen and J.M.Duncan

Scottish Crop Research Institute, Invergowrie, Dundee, DD2 5DA, UK.

Summary

A sensitive specific real-time PCR (Taqman®) assay was developed for the detection and quantification of the potato pathogen *Spongospora subterranea* f.sp. *subterranea*. *S.subterranea* DNA was detected and quantified from sporeballs in soil and water, plasmodia and zoosporangia in bait plant roots and zoospores in nutrient solution. The assay consistently detected *S.subterranea* DNA at 0.025 sporeball equivalents. In combination with the tomato bait plant technique, the assay reliably detected inoculum at ≥ 0.5 sporeballs ml⁻¹ nutrient solution. The assay is a valuable tool for epidemiological studies of PMTV and its vector and can be used in studies of host resistance, survival in the field, latent tuber infections and alternative hosts.

Introduction

Powdery scab caused by *Spongospora subterranea* f.sp. *subterranea* (*S.s*), is characterised by galls on roots, and cankers and scabs on tubers, and results in extensive losses to seed and ware crops. Scabs on tubers contain masses of cystosori, which can survive in soil for many years. Under moist conditions cystosori release primary zoospores, which can infect potato and other plant hosts. Following host infection, plasmodia are formed in the roots and can develop into zoosporangia, which release secondary zoospores when mature. *S. s* is also the vector of *Potato Mop Top Virus* (PMTV), one of the causes of spraing (Stevenson *et al.*, 2001).

No effective disease control methods are available for powdery scab or spraing and many aspects of the biology of *S.s* are poorly understood. The quantification of *S.s* in soil, water and plant tissue is essential to allow detailed studies into the epidemiology and control of powdery scab and spraing. An Enzyme Linked Immunosorbent Assay (ELISA) for quantifying *S.s* is available, but cannot detect low levels of inoculum in soil (Walsh *et al.*, 1996). Quantification of *S.s* DNA is also possible by competitive PCR (Bell *et al.*, 1999; Qu *et al.*, 2000). However, a more rapid and accurate method such as Real-time (TaqMan®) PCR is needed for processing of large sample numbers. This method has been used with success for the detection and quantification of fungi (Cullen *et al.*, 2001), bacteria (Hyman *et al.*, 2000) and viruses (Boonham *et al.*). The objective of this work was to develop a sensitive and quantitative real-time PCR assay specific to *S. subterranea* f.sp. *subterranea* that could be used as a reliable tool for the detection and quantification of this important potato pathogen and virus vector in plant tissue, water and soil.

Materials and Methods

Cystosori of *S.s* were obtained from scabbed tubers grown in Scotland. For detection sensitivity experiments, soil was air dried, sieved and stored at room temperature before addition of cystosori at concentrations of 0, 1, 3, 5, 10, 30, 50, 100 and 500 per 10 g sample. Tomato bait plants were inoculated with *S.s* by addition of cystosori (0, 5, 15, 25, 50, 150, 250, 500 or 2500 per 50 ml) to the nutrient solution (Merz 1989) in which they were grown. After two weeks of baiting, tomato roots were washed, dried and frozen before DNA extraction. The nutrient solution remaining in each pot was filtered and frozen before DNA extraction. DNA was

extracted from cystosori in soil and water samples according to Bell et al. (1999) and from tomato root samples and zoospores using a Nucleon® PhytoPure plant DNA extraction kit.

Primer design

Putative *S.s* specific forward and reverse primers SBITS5F and SBITS4R and a TaqMan® fluorogenic probe SsTQP1 were designed from the ITS region for use in a real-time quantitative PCR assay. The probe was labelled at the 5' end with the fluorescent reporter dye FAM and at the 3' end with the quencher dye TAMRA.

Real-time PCR amplification

Real-time quantitative PCR reactions were performed using 1 µl template DNA, primers SBITS5F and SBITS4R and fluorogenic probe SsTQP1 according to the Applied Biosystems protocol. Controls and a range of standards (*S.s* DNA equivalent to 100000, 10000, 1000, 100, 25 and 10 cystosori ml⁻¹) were included. The Ct value was calculated for each unknown sample and compared to the Ct values of the standard series. The amount of *S. s* DNA in each unknown sample was expressed in cystosori equivalents. DNA extracted from cystosori collected from 16 different locations in N.Britain was amplified using the above method and the specificity of the TaqMan® primers and probe was tested using genomic DNA from a range of micro-organisms.

Results

Sensitivity and specificity

S.subterranea DNA equivalent to 100, 10, 1.0, 0.1 and 0.025 cystosori was consistently amplified using the real-time PCR assay. The non-template control was not detectable. The assay was able to detect DNA of *S. s* from all sixteen sources tested. DNA of other micro-organisms was not amplified in the real-time PCR assay.

Detection and quantification of cystosori in water and soil

The assay could reliably detect and quantify cystosori in water and soil. The average amount of DNA detectable from cystosori in water was consistent at concentrations >1 cystosorus ml⁻¹, and comparable to the numbers originally added (Table 1). The detection rate of cystosori in clay soil was high for most inoculum levels, possibly due to natural contamination of the soil. Quantification of cystosori in soil was less accurate than in water (Table 1).

Table 1. Detection and quantification of *Spongospora subterranea* f.sp. *subterranea* after direct extraction of DNA from cystosori in water and soil (n = 5). DNA was quantified by real-time PCR (TaqMan®) assay

Inoculum (cystosori ml ⁻¹ or g ⁻¹)	Extraction from cystosori in water			Extraction from cystosori in soil		
	% positive samples	Mean amount of DNA detected ± S.E.	(units ¹ per ml)	% positive samples	Mean amount of DNA detected(units per g) ± S.E.	
0	0	0	± 0	80	0.5	± 0.2
0.1	20	0.03	± 0.03	80	0.8	± 0.3
0.3	40	0.2	± 0.1	40	0.8	± 0.5
0.5	40	0.1	± 0.1	80	1.4	± 0.6
1	60	1.0	± 0.7	60	2.2	± 1.8
3	100	3.4	± 1.5	80	2.3	± 0.7
5	80	4.6	± 1.4	60	1.3	± 0.8
10	100	14.6	± 5.6	100	3.8	± 1.7
50	100	41.2	± 15.8	100	37.0	± 11.3

1. One unit equals the amount of DNA extracted from a single cystosorus of average size.

Detection and quantification of plasmodia, zoosporangia and zoospores

Plasmodia and zoosporangia of *S. s* formed in the roots of tomato plants during a bait test, were detectable (Table 2). Amplification was consistent at inoculum concentrations > 0.3 cystosori ml⁻¹ and *S. s* was detected in almost all plant samples inoculated with > 1 cystosorus ml⁻¹. The average quantity of *S. s* DNA detected in inoculated plants was always higher than the quantity present in the initial inoculum, showing that the pathogen had multiplied within the host tissues. The assay was able to detect zoospores of *S. s* in nutrient solution at all levels of added inoculum (Table 2). In the bait plant test, the quantity of *S. s* DNA detected in the roots and nutrient solution was greater in samples with initial inoculum concentrations of 5 or 10 cystosori ml⁻¹ than 50 cystosori ml⁻¹.

Table 2. Detection and quantification of DNA of *Spongospora subterranea* f.sp. *subterranea* after extraction from plasmodia and zoosporangia in tomato roots and zoospores in nutrient solution after a bait plant test (n = 5). DNA was quantified by real-time PCR (TaqMan®) assay

Inoculum (cystosori ml ⁻¹)	Extraction from plasmodia and zoosporangia in bait plant roots			Extraction from zoospores in bait plant nutrient solution		
	% positive samples	Average amount of DNA detected (units ¹ per mg dry weight) ± S.E.		% positive samples	Average amount of DNA detected (10 ⁻³ units per ml) ± S.E.	
0	0	0	± 0	0	0	± 0
0.1	40	1.3	± 0.8	20	0.6	± 0.6
0.3	60	1.5	± 1.2	40	1.9	± 1.2
0.5	80	4.8	± 1.5	60	2.1	± 0.9
1	60	8.1	± 5.1	20	1.4	± 1.4
3	80	88.5	± 31.3	60	7.7	± 4.5
5	100	1855.6	± 607.7	100	118.8	± 105.9
10	100	1683.2	± 671.8	100	114.0	± 51.7
50	100	1564.4	± 822.8	60	30.3	± 24.9

1. One unit equals the amount of DNA extracted from a single cystosorus of average size

Discussion

The real-time PCR assay could detect *S.subterranea* in water, soil and plant tissue. Specificity of the primers and probe was confirmed and DNA samples from 16 different locations in Northern Britain were all amplified. The assay was very sensitive with consistent amplification of standard DNA quantities equivalent to 0.025 cystosori (in 1 µl) in water. These results are similar to the minimum detection levels for conventional PCR (Bell et al. 1999) and ELISA (Walsh et al., 1996).

The assay was also able to detect and quantify *S. s* in contaminated soil at concentrations < 2 cystosori g⁻¹. Using the protocol of Bell et al. (1999), the *S.s* detection limit should be 2 cystosori g⁻¹ soil and these authors and Qu et al. (2000) reported detection of ≥ 5 and ≥ 4 cystosori g⁻¹ soil respectively using conventional PCR. ELISA can detect and reliably quantify high levels of cystosori in soil (> 2000 cystosori g⁻¹) (Walsh et al., 1996).

Bait plants can be used to test soil or other substrates for the presence of *S. s* (a detection sensitivity of 0.1 cystosori ml⁻¹ nutrient solution has been reported (Burnett, 1991)). However, detection and quantification relies on microscopic examination of stained bait plant roots, which is unreliable. This problem can be overcome by combining the bait plant test with a PCR assay. Conventional PCR has been used for the detection of *S. s* in bait plant roots, but without quantification of the level of infection of individual plants (Bouchek-Mechiche et al., 2000). The real-time PCR assay can reliably detect and quantify *S. s* in bait plant roots at initial inoculum concentrations ≥ 0.5 cystosori per ml, and can therefore be combined with the bait plant test.

Zoospores were successfully detected using the real-time PCR assay, but the results were less consistent than those for roots. This could be due to the fragile nature of the zoospores or to the fact that the majority of zoospores were already attached to the host roots at the time of sampling.

The real-time PCR assay described is a specific, sensitive and reliable method for the detection and quantification of the different life stages of *S. subterranea* f.sp. *subterranea* in a range of sample types. With this assay, a large number of samples can be processed quickly and easily. The detection limits of the real-time PCR assay are similar to or better than with existing detection methods such as visual examination of bait plant roots, ELISA and conventional PCR, and the method allows quantification in samples with varying levels of *S. s* DNA, either after DNA extraction directly from field samples or in combination with a bait plant test. Real-time PCR is a technique that could be applied in practice for diagnostics and disease risk assessment and can be used in epidemiological studies of *S. s*. For example to determine the relative importance of different sources of inoculum, the likelihood of PMTV transmission, to assess the susceptibility of potato varieties and alternative hosts to root infection and to detect latent and immature infections of seed tubers and the effect of environmental factors on the release of zoospores. In short, the real-time PCR assay would be a valuable tool in any future studies on the epidemiology and control of powdery scab caused by *S. subterranea* f.sp. *subterranea* or spraing caused by PMTV.

References

- Bell KS, Roberts J, Verrall S, Cullen DW, Williams NA, Harrison JG, Toth IK, Cooke DEL, Duncan JM and Claxton JR (1999) Detection and quantification of *Spongospora subterranea* f.sp. *subterranea* in soils and on tubers using specific PCR primers. *European Journal of Plant Pathology* 105: 905-915
- Boonham N, Walsh K, Mumford RA and Barker I (2000) Use of multiplex real-time PCR (Taqman) for the detection of potato viruses. *EPPO Bulletin* 30: 427-430
- Bouchek-Mechiche K, Ruer D, Andrivon D and Jouan B (2000) The detection of *Spongospora subterranea* by bioassays, molecular and serological methods. *Proceedings First European Powdery Scab Workshop, SAC, Aberdeen, Scotland, July 20-22, 2000*: 61-65
- Burnett FJ (1991) *The Biology and Control of Powdery Scab (Spongospora subterranea) of Potatoes*. PhD thesis, University of Aberdeen, Aberdeen, UK
- Cullen DW, Lees AK, Toth IK and Duncan JM (2001) Conventional PCR and real-time quantitative PCR detection of *Helminthosporium solani* in soil and on potato tubers. *European Journal of Plant Pathology* 107: 387-398
- Hyman LJ, Birch PRJ, Dellagi A, Avrova AO and Toth IK (2000) Development of a quantitative PCR-based detection system for *Erwinia carotovora* subsp. *atroseptica* on potato tubers. *EPPO Bulletin* 30: 409-411
- Merz U (1989) Infectivity, inoculum density and germination of *Spongospora subterranea* resting spores: a solution-culture test system. *EPPO Bulletin* 19: 585-
- Qu XS, Kavanagh JA and Egan D (2000) Quantification of the fungal cause of potato powdery scab in soil using a competitive polymerase chain reaction assay. *Faculty of Agriculture, University College Dublin, National University of Ireland. Research Report 1998-1999*: 74-76
- Stevenson WR, Loria R, Franc GD and Weingartner DP (2001) *Compendium of Potato Diseases*. 2nd ed. APS, St Paul, USA
- Walsh JA, Merz U and Harrison JG (1996) Serological detection of spore balls of *Spongospora subterranea* and quantification in soil. *Plant Pathology* 45: 884-895

IMPROVED IMMUNOLOGICAL DIAGNOSTICS FOR *SPONGOSPORA SUBTERRANEA*

U. Merz¹ and J.A. Walsh²

¹Institute of Plant Sciences, Phytopathology Group, Federal Institute of Technology, 8092 Zurich, Switzerland, ²Horticulture Research International, Wellesbourne, Warwick, UK

Summary

The genus *Spongospora* has two members which are important pathogens of vegetables, *S. subterranea* f.sp. *subterranea* (*Sss*) and *S. subterranea* f.sp. *nasturtii* (*Ssn*). The close taxonomical relationship is mainly based on similar cystosori morphology. The potato disease powdery scab, caused by *Sss*, is difficult to control. The key control measure is avoidance, aiming to plant clean seed into clean soil. For the development of routine tests for the presence of the pathogen on tubers and in soil, MAbs were produced using *Sss* cystosori as immunogen. These were able to detect as little as 0.068 *Sss* cystosori. They recognized *Sss* material from many parts of the world. No cross-reactions with other *Plasmodiophoromycetes* like *P. brassicae* or different *Streptomyces* species that cause common scab were observed. A standardized sample test method was developed using a kitchen peeling machine. This detected 1 tuber with 1 powdery scab lesion in a sample including 19 uninfected tubers. When soils were tested with the antiserum, different *Sss* infestation levels could be discriminated. *Ssn* cystosori gave absorbance values in ELISA as high as *Sss* cystosori, whereas fresh crook roots or mud from a watercress bed only gave low absorbance values or no reaction. The potential of these findings are discussed.

Introduction

The genus *Spongospora* together with eight other genera belongs to the division *Plasmodiophoromycota*, included in the Kingdom *Protozoa*, according to Braselton (1995). As there is much uncertainty about their systematic classification, the author introduces the informal term Plasmodiophorids. Several Plasmodiophorids are significant pathogens and most of the 'fungal' vectors belong to this group. The two important members of *Spongospora*, *S. subterranea* (Wallroth) Lagerheim f.sp. *subterranea* Tomlinson (*Sss*) and *S. subterranea* (Wallroth) Lagerheim f.sp. *nasturtii* Tomlinson (*Ssn*) are the only virus vectors which are also plant pathogens. Both are obligate parasites and spread with zoospores. Their resting spores (sporeballs, cystosori) have a characteristic spongiforme-like structure in common and enables them to survive for longtime.

A soil once infested with *Sss* will stay infective for up to ten years. No effective control measures, except avoidance, are available. The contamination levels of field soils are difficult to determine. Although bioassays involving the baiting of soil samples with tomato (Merz, 1989) or potato (Wale *et al.*, 1993) seedlings have been used they are very labour intensive, slow and results may not correlate well with disease levels observed in the field. Visual inspection of seed tubers normally unwashed has the risk of misidentification. Sensitive and rapid detection of resting spores of *Sss* both on tubers and in field soils and of *Ssn* spores in waterbed soil would be a great aid to the development of disease management strategies.

Serology and molecular markers have already been used to develop detection methods for *Sss* and *Ssn*. Harrison *et al.* (1993) and Walsh *et al.* (1996) described the development of an enzyme-linked immunosorbent assay (ELISA) with polyclonals for the detection of *Sss* resting spores on potato tubers and in field soil respectively. Monoclonal antiserum produced against zoospores did not detect resting spores (Wallace *et al.*, 1995). Bulman and Marshall (1998) and Bell *et al.* (1999) designed molecular primers which can detect *Sss* in small amounts but

detection and quantification in soil still needs improvement. Down and Clarkson (2002) developed a sensitive PCR-based detection system for *Ssn* but concentrated mainly on zoospores.

This paper describes the sensitivity and specificity of a new monoclonal antiserum, developed against the resting spores of *Sss*, and its potential for detection of *Sss* and *Ssn*.

Material and Methods

Production of monoclonal antiserum

The antiserum was produced by the company BIOREBA AG, Reinach, Switzerland. Cystosori preparation (40-80 µm fraction), as described in Merz (1989), was used for immunization.

ELISA

To test the antiserum performance, a double-antibody sandwich (DAS) ELISA was used. The IgG was diluted 1 in 1000 in 0.05mol L⁻¹ sodium carbonate buffer (pH 9.6) and pipetted into each of 2 wells (200 µl/well) of microtitre plates (Nunc-Immuno Plate Maxi Sorp F96; Gibco Ltd., Uxbridge, UK) and incubated overnight (16h) at 4°C. Subsequently the plates were incubated for 2h at 37°C with sample homogenates ground in extraction bags ('Universal') and a hand homogenizer (both BIOREBA AG, Reinach, Switzerland; cystosori, plant material) or with pestle and mortar (soil) in TRIS-buffered saline containing Tween 20 (0.05%) and PVP (2% w/v) (pH=7.4; 150 µl/well). This was followed by IgG conjugated to alkaline phosphatase diluted 1 in 1000 in TRIS-buffered saline containing Tween 20 (0.05% v/v), PVP (2% w/v), BSA (0.2% w/v) and MgCl₂ hexahydrate (0.02% w/v) (pH=7.4; 150 µl/well) for 3h at 37°C. Finally the plates were incubated with substrate (2-nitrophenyl phosphate (Sigma 104 phosphatase substrate tablets; 1/5 ml) in 10% diethanolamine adjusted to pH 9.8 with HCl) (150 µl/well) at room temperature and the optical adsorbance at 405 nm (A405) was measured with an Anthos Labtec HT2 microplate reader (Tech Gen International, London, UK) blanked against unused wells or appropriate uncontaminated material.

Sensitivity

A subsample of quantified cystosori material from potato cv Bintje was adjusted to a concentration of 100 cystosori/well in TRIS-buffered saline and further diluted to obtain the following concentrations: 42.5, 8.5, 1.7, 0.34, 0.086 and 0.013 cystosori/well.

The same cystosori material and uninfested soil were used to prepare a dilution series containing 8000, 6000, 4000, 2000, 1000, 500 and 100 cystosori/g soil. A sample of 1g of each dilution was ground in 2ml TRIS-buffered saline. Additionally a similar dilution series was made with cystosori alone.

The soil containing 500 cystosori/g was compared to a naturally infested field soil from a powdery scab trial site and a peat substrate used for minituber production, which turned out to be heavily infested.

Specificity

Equal amounts of cystosori material from Switzerland, Denmark, Sweden, Scotland, Japan, New Zealand USA and Peru and potato peelings from France, The Netherlands, Chile and Ecuador were ground in TRIS-buffered saline (0.1g/5ml)

Cross reaction of the antiserum was tested with different *Streptomyces* strains (pure cultures of *S. scabies*, *S. acidiscabies*, *S. stelliscabiei*, *S. europaeiscabieis*, *S. reticuliscabiei* and *S. turgidiscabieis*) as well as with peelings of tubers showing netted and common scab symptoms. Further samples of roots infected with the closely related Plasmodiophorid organisms *Plasmodiophora brassicae*, *Polymyxa betae* or *P. graminis* were tested. The ability to detect resting spores from *Ssn* was also tested. Crooks from infected watercress roots, dried, stored

and microscopically checked for the presence of sporeballs, crooks from fresh plants and soil from the same bed were ground.

Potato sample test procedure

To test a practical method for screening a sample of tubers for the presence of *Sss*, a commercial kitchen peeling machine was used. Different fractions of healthy tubers vs peeled tubers with one lesion left in a total of 20 tubers were processed: 20:0, 19:1, 18:2, 16:4, 12:8, 4:16. Each lot was treated for 12 sec while flushed with about 500ml of tap water. Two water samples of 200 μ l were then taken for ELISA.

Results

Sensitivity

The sample containing 0.068 cystosori gave an A_{405} value of 0.161 whereas 0.013 cystosori gave a value of 0.005. When artificially infested soil (spiked) was tested, the sample with 100 cystosori per gram was discriminated from the uninfested control but the A_{405} value was ten times lower than the A_{405} value of the equivalent amount of cystosori (Fig. 1). Samples from a heavily infested trial site (0.63) and from peat substrate (0.50) gave higher A_{405} values than the 500 cystosori/g soil sample (0.22).

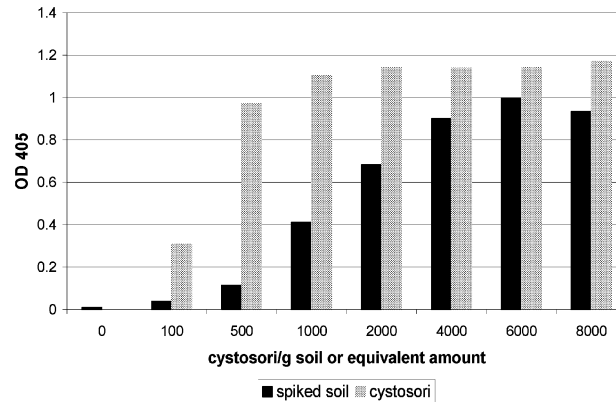

Fig. 1 The relationship between the concentration of sporeballs of *Sss* in spiked soil samples or the equivalent amount of sporeballs and A_{405} in a DAS ELISA test.

Specificity

The samples from Chile, Denmark, Ecuador, France, Japan, New Zealand, Peru, The Netherlands, Scotland, Sweden, Switzerland and USA gave similar A_{405} values.

There was no reaction between the antiserum and pure cultures of six *Streptomyces* species or peelings with common scab symptoms. Also the closely related micro-organisms *P. brassicae*, *P. graminis* and *P. betae* did not react with the antiserum.

Dried and stored crooks from watercress roots containing resting spores of *Ssn* gave a similar A_{405} value compared to a Swiss *Sss* cystosori homogenate ($Ssn=1.39$, $Sss=1.43$). Lower values were obtained when samples from fresh watercress roots with crook symptoms were tested (0.31 and 0.06). Soil samples from the beds where the infected plants have been taken, gave no reaction.

Potato sample test procedure

Only a slightly higher A_{405} value was obtained when 200 μ l of flushing water of the tuber sample with the lowest fraction (19 healthy and one tuber with a single lesion) were tested, compared to the healthy control (HC=0.022, 19:1=0.028) whereas two tubers with one lesion together with 18 healthy tubers gave a clear difference (18:2=0.10; Fig. 2).

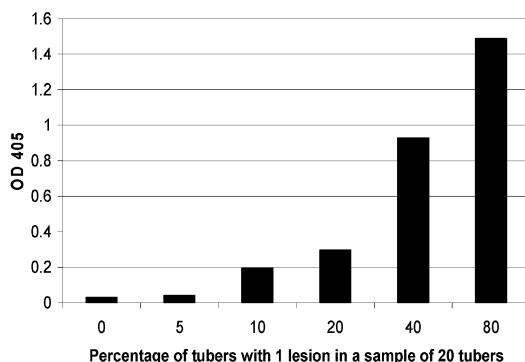

Fig. 2 The A_{405} values of lots with 20 tubers and an increasing percentage of peeled tubers with 1 powdery scab lesion left in a DAS ELISA test. The tubers were treated in a kitchen peeling machine and probes of the flushing water were tested.

Discussion

The results presented here show the potential of the monoclonal antiserum not only to detect *Sss* on tubers and in soil but also to verify the presence of resting spores of *Ssn*. Little is known about the role of the resting spores in the biology and epidemiology of *Ssn*. The new monoclonals will provide a useful tool in future studies.

The cystosori of *Sss* and *Ssn* show similarity in the immunological reaction. In contrast to this, both Bulman and Marshall (1998) and Bell *et al.* (1999) did not find much homology between the DNA sequences of parts of the ITS region. The recognized epitope could be a wall protein common in both types of resting spores.

The antibody is sensitive enough to detect e.g. tuber infection levels much below the powdery scab infection limit for seed tuber lots in Switzerland (not more than 1% with more than 5 lesions).

Acknowledgements

We would like to thank BIOREBA AG, Reinach, Switzerland, for providing the antibody and K. Bouček, INRA, Rennes, France, for providing the *Streptomyces* data.

References

- Bell K.S., J. Roberts, S. Verrall, D.W. Cullen, N.A. Williams, J.G. Harrison, I.K. Toth, D.E.L. Cooke, J.M. Duncan and J.R. Claxton, 1999. Detection and quantification of *Spongospora subterranea* f.sp. *subterranea* in soils and on tubers using specific PCR primers. *European Journal of Plant Pathology* 105, 905-915.
- Braselton J.P., 1995, Current status of the Plasmodiophorids. *Critical Reviews in Microbiology* 21 (4), 263-275.
- Bulman S.R. and J.W. Marshall, 1998. Detection of *Spongospora subterranea* in potato tuber lesions using the polymerase chain reaction (PCR). *Plant Pathology* 47 (6), 759-766.
- Down G.J. and J.M. Clarkson, 2002, Development of a PCR-based diagnostic test for *Spongospora subterranea* f.sp. *nasturtii*, the causal agent of crook root of watercress (*Rorippa nasturtium-aquaticum*). *Plant Pathology* 51, 275-280.
- Merz U. (1989). Infectivity, inoculum density and germination of *Spongospora subterranea* resting spores: a solution-culture test system. *EPPO Bulletin* 19, 585-592.
- Harrison J.G., Rees E.A., Barker H. & Lowe R. (1993). Detection of spore balls of *Spongospora subterranea* on potato tubers by enzyme-linked immunosorbent assay. *Plant Pathology* 42, 181-186.

- Wale S.J., Burgess P.J. & Burnett F. (1993). Bioassay for *Spongospora subterranea* detection in soil and its potential use in predicting powdery scab in the field. Proceedings of 6th International Congress of Plant Pathology, Abstract 16.4.2, p.281.
- Wallace A., N.A. Williams, R. Lowe and J.G. Harrison, 1995, Detection of *Spongospora subterranea* using monoclonal antibodies in ELISA. Plant Pathology 44 (2), 355-365.

BROAD-SPECTRUM DETECTION OF *POLYMYXA* SPECIES AND FORM SPECIES BY POLYMERASE CHAIN REACTION.

A. Legrève¹, P. Delfosse², V. Van Hese¹, C. Bragard¹ and H. Maraite¹

¹Unité de Phytopathologie, Université catholique de Louvain, Croix du Sud, 2bte 3, B-1348 Louvain-la-Neuve, Belgium; ²ICRISAT, BP 12 404 Niamey, Niger

Summary

The plasmodiophorids *Polymyxa graminis* and *P. betae* are vectors of beny-, bymo-, furo-, peclu- and pomoviruses causing severe diseases on major crops. These two species share an identical morphology, but are distinguished on the basis of their ability to develop or not in *Gramineae*. Recently five special forms were described within *P. graminis* based on the ecotypes and the genotypes associated with various viruses. Control measures for *Polymyxa*-transmitted viral diseases are based on knowledge of ecological requirements and inoculum potential of the vector. The latter is difficult to assess because it is based on the use of bait plants combined with tedious microscopic observations. In order to avoid this difficulty, a broad-spectrum detection method by molecular tools has been developed in two steps: 1/ a total DNA extraction including DNA from the resting spores and 2/ a PCR with primers designed from known *Polymyxa* spp. and f. sp. sequences. This method is highly reliable for the detection of *Polymyxa* in roots. Its use for the detection of *Polymyxa* directly from soil provides encouraging results. This method is used for studies on the epidemiology of *Polymyxa*-transmitted diseases.

Introduction

Polymyxa graminis and *P. betae* are obligate root endoparasites. Despite that both species are morphologically similar, they are considered as distinct based on their separate host ranges. *P. graminis* is a parasite of Poaceae to which it transmits viruses belonging to *Beny*-, *Bymo*-, *Furo*-, and *Pecluvirus*. *P. betae* infects mainly Chenopodiaceae and vectors *Beny*- and *Pomovirus*. *Polymyxa* spp. are not truly considered as pathogens but as vectors of phytoviruses, and they play crucial role in the epidemiology of viral diseases. Survival and transmission of the viruses entirely rely on the vector's development. *Polymyxa* spp. survives as clusters of resting spores released in the soil after roots decomposition. Provided with a very resistant wall, the spores may survive for several decades.

The management of the *Polymyxa*-transmitted diseases and the control of their spread require knowledge on infection rate in cultivated plants species and varieties. Despite the importance of this information for sustainable agriculture and the great interest for the breeders, relatively little has been done in this field because of the difficulties to study it. As an obligate parasite, it is not possible to grow *Polymyxa* on artificial medium. Its infection does not induce particular symptoms and its detection requires tedious microscopic observations of stained roots. There is therefore a clear need for alternative detection methods.

The sequences of nuclear ribosomal DNA regions from isolates of *P. graminis* and *P. betae* obtained by Ward and Adams (1998) led them to suggest specific primer pairs for the detection of *Polymyxa* spp. Molecular studies have shown that the polymorphism within *P. graminis* was greater than previously thought (Morales *et al.*, 1999, Legrève *et al.*, 2002). These genomic characteristics in combination with specific host range and temperature requirements were even the basis of the description of five special forms within this species (Legrève *et al.*, 2002). Here we report a routine method for the detection of *Polymyxa* species and form species by PCR using total DNA extract from infected roots. This method was successfully applied for the detection of *P. graminis* associated with the peanut clump disease in West Africa. Its use for the detection of *Polymyxa* from other areas or directly from the soil was also attempted.

Materials and Methods

Plant and soil material

Reference *Polymyxa* isolates stored in dried roots of barley, pearl millet, sorghum, and sugar beet were used for adjusting the PCR conditions. Roots of maize, pearl millet, sorghum and wheat grown for 3 to 8 months at 23-30°C on soils collected in West Africa then stored at -20°C before being used to assess the detection by PCR. The presence of *Polymyxa* was controlled by microscopic observation of another part of the roots (Table 2). *Polymyxa* presence was also assessed in a dried root of wheat collected by M. Henry (CIMMYT) at Toluca in Mexico. Seven soil samples infested by *Polymyxa* were used for assessing the possibility to detect it directly from the soil.

DNA extraction

The extraction of total DNA from roots was done using the FastPrep® System (Qbiogene, Appligene, France). *Polymyxa* infected roots were added to a micro-tube containing the Lysing Matrix Combination 1/4" Sphere + Garnet Matrix of the FastDNA® Kit. The extraction was made following the manufacturer's instructions, using CLS-Y as cell lysis solution. The shaking in the FastPrep® Instrument was processed twice for 45 seconds at speed 6 with a break of 5 minutes. The DNA extract was ten-fold diluted in di-ethyl pyrocarbonate (DEPC) treated water and stored at -20°C for further PCR reaction. The extraction of DNA from the soil was done following the same protocol using 600 µg of soil per sample. Three cell lysis solutions were tested (CLS-VF+PPS, CLS-TC and CLS-Y) and concluded to the using of the CLS-VF+PPS. The shaking in the FastPrep® Instrument was processed twice at speed 5.5 and for 40 seconds.

Table 1. Expected length of the DNA fragments after amplification with primer pairs ITS5-Pxrev7 and Psp1-Psp2rev

<i>Polymyxa</i> spp and f. sp	ITS5-Pxrev7	Psp1-Psp2rev
<i>P. betae</i>	307	454
<i>P. graminis</i> f. sp. <i>colombiana</i>	352	499
<i>P. graminis</i> f. sp. <i>temperata</i>	325	472
<i>P. graminis</i> f. sp. <i>tepida</i>	353	500
<i>P. graminis</i> f. sp. <i>tropicalis</i>	320-322	467-469
<i>P. graminis</i> f. sp. <i>subtropicalis</i>	361	~508

Design of primers and PCR conditions

Two primer pairs were chosen for broad-spectrum and specific detection of *Polymyxa* on the basis of nuclear ribosomal DNA sequences obtained from a set of isolates from various origins along the world. The first one consisted in the ITS5 (White *et al.*, 1990) and Pxrev7 primers (Ward and Adams, 1998) (Table 1). ITS5 is a non-specific primer commonly used in mycology for studying nuclear rDNA. In combination with the primer Pxrev-7 annealing with a part of the 5.8S gene specific to *Polymyxa* and common to further *Polymyxa* sequences described after, it allowed the detection of *P. betae* and the 5 special forms of *P. graminis* currently described (Legrève *et al.*, 2002). The length of the fragment amplified varied from 307 to 361 bp (Table 1). The other pair of primers Psp1 (TAGACGCAGGTCATCAACCT, in nuclear small rDNA region) and Psp2rev (AGGGCTCTCGAAAGCGCAA, in 5.8s gene) was designed for amplifying a longer region from 454 to 509 bp, by annealing specifically with *Polymyxa* sequences at both sides. The specificity of these primers to *Polymyxa* was assessed by BLAST (Altschul *et al.*, 1990).

PCR protocol

The PCR was carried out in 200 µl microtubes filled with 25 or 50 µl reaction volume. Each 50 µl mixture was prepared with 31 µl DEPC water, 5 µl 10x thermophilic DNA polymerase buffer Promega (Madison, USA), 5 µl MgCl₂ 25mM Promega, 1 µl of each primer at 20 picomoles/µl, 1.5 µl dNTPs, 0.5 µl Taq DNA polymerase Promega 5 U/µl and 5 µl of DNA extract. The PCR was performed in the Applied Biosystems GeneAmp® PCR system 2700. A first denaturation was performed at 94°C for 2 minutes. Then 35 cycles including denaturation of 30 seconds at 94°C, annealing at 52°C for primers ITS5-Pxrev7 or 60°C for primers Psp1-Psp2rev and

elongation at 72°C for 30 or 35 seconds, for ITS5-Pxrev7 or Psp1-Psp2rev, respectively, were carried out. A final elongation was completed at 72°C for 7 minutes. For each set of primers, a gradient of annealing temperatures was previously tested with the iCycler of Bio-Rad® on a set of template DNA samples. After PCR amplification, 2 µl of loading buffer was added to the PCR products. The samples were loaded on 1.75% agarose gel in Tris Borate-EDTA buffer and the electrophoresis was performed in Sub-Cell® GT Agarose Gel Electrophoresis Systems Bio-Rad. After ethidium bromide staining, the bands were visualized using the Gel Doc 2000 of Bio-Rad®.

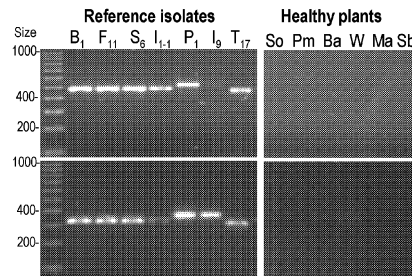

Fig. 1. PCR amplification using the primers Psp1-Psprev2 (above) or ITS5-Pxrev7 (below) of isolates of *P. betae* (T₁₇) from Turkey on sugar beet (SB), *P. graminis* f. sp. *temperata* from Belgium (B₁) and France (F₁₁) on barley (Ba), *P. graminis* f. sp. *tropicalis* from Senegal (S₆) on pearl millet (Pm), and India (I₁₋₁) on sorghum (So) and *P. graminis* f. sp. *subtropicalis* (P₁) from Pakistan and (I₉) India on So, and healthy roots of 6 species (Ma = maize, W = wheat)

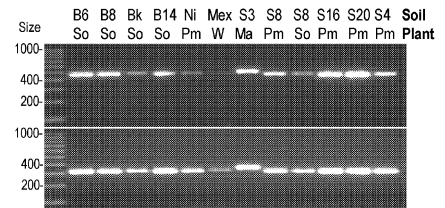

Fig. 2. Detection of *Polymyxa* by PCR using the primers Psp1-Psprev2 (above) or ITS5-Pxrev7 (below) in roots of maize (Ma), sorghum (So), pearl millet (Pm), or wheat (W) grown on soils from Burkina Faso (B), Mexico (Mex), Niger (N) and Senegal (S)

Results

Both primer pairs tested amplified the DNA sequence of the reference *Polymyxa* isolates (Fig. 1). The fragment sizes corresponded to those expected from the sequences of the homologous species or form. The detection by PCR using these primers was assessed on roots of cereal plants used for baiting

Polymyxa from soils originating from Burkina Faso (BF), Mali, Niger and Senegal collected in peanut clump-infested areas (Table 2). *Polymyxa* was detected by PCR using both primer pairs in 37 out of the 85 analyzed roots (Fig. 2). The presence of *Polymyxa* sporosori was confirmed by microscopic observation for 32 out of these 37 roots but some fungal structures looking like plasmodia were scarcely seen in the other roots, without allowing a clear identification. *Polymyxa* was not detected in 44 of the 85 root samples whatever the method used (PCR detection method with both sets of primers and microscopy). Divergent results between the PCR performed with one or the other primer pair were obtained for four DNA extracts. The microscopic observation of root samples corresponding with these DNA extracts confirmed the PCR diagnostic in one out of these four. The infection within this root system was very restricted. *Polymyxa* was detected from the six soils collected in BF, 14 out of the 18 soils from Senegal and on the soil from Niger. The PCR method using both pairs of primers was also successfully applied for detecting *Polymyxa* in wheat roots collected from Toluca in Mexico (Fig. 2). In a few cases, a slight band of higher size than the ones assessed for *Polymyxa* has been

Table 2. Results and correlation between the detection of *Polymyxa* by PCR using primers pairs ITS5-Pxrev7 (A) or Psp1-Psprev2 (B) and by microscopy (C).

Origin of the soils*	Total tested root samples	Number of samples with positive result using			
		A, B & C	A only	B only	A & B B & C
Burkina Faso (6)	10	10	0	0	0
Mali (1)	2	0	0	0	0
Niger (1)	2	2	0	0	0
Senegal (18)	71	20	1	2	5
Total (26)	85	32	1	2	5

*Under brackets the number of soil samples tested

observed when the PCR was processed using DNA extracted from pearl millet not infected by *Polymyxa* (Fig. 1). This band was not always present and not observed when *Polymyxa* was present in pearl millet samples. *P. betae* was detected by PCR using Psp1-Psp2rev on DNA extracts made directly from 3 Belgian soils affected by rhizomania (Beclers, Malèves-Ste-Marie and Mazy). This method allowed the detection of *P. graminis* from a soil from Thisnes collected by S. Steyer in Belgium, but not from 3 other soils expected to be infested.

Discussion

A method for detection of *Polymyxa* by PCR from root and soil samples using the FastPrep System and DNA amplification with two different pairs of primers was successfully developed. It allowed the amplification of *P. graminis* and *P. betae* DNA in dried or fresh roots. This method was applied for screening *Polymyxa* infection in bait-plants grown in soils. The correlation between the detection by PCR and the microscopic observation was excellent (90%). The higher detection rate obtained with the PCR method compared to visual observation suggests that the detection by PCR is more sensitive. This method is a useful tool for *Polymyxa* studies and for facilitating selection of resistant varieties. Detection of *Polymyxa* by DNA extraction directly from the soil hastens detection of the parasite by skipping the step required for baiting *Polymyxa* in plants. The optimization of the DNA extraction from soil samples, by a pretreatment of the soil or by using more complex extraction process may improve the detection threshold. For example, soil humectation for 24 hours before extraction increased the detection. The PCR method will be beneficial for *Polymyxa* characterization. The size of the amplified fragment provides an indication of the species or the form species present. Different sets of primer pairs designed for their specific detection are under development.

Acknowledgements

The authors wish to thank the Directorate General International Cooperation Brussels, Belgium for funding the research project.

References

- Altschul, S.F., Madden, T. L., Schäffer, A. A., Zhang, J., Zhang, Z., Miller, W. and Lipman, D.J. (1997). Gapped BLAST and PSI-BLAST: a new generation of protein database search programs. *Nucleic Acids Res.* 25, 3389-3402.
- Legrève, A., Delfosse, P., and Maraite, H. (2002). Phylogenetic analysis of *Polymyxa* species based on nuclear 5.8S and internal transcribed spacers ribosomal DNA sequences. *Mycological Research* 106,138-147.
- Morales, F. J., Ward, E., Castano, M., Arroyave, J. A., Lozano, I. and Adams, M.J. (1999). Emergence and partial characterization of rice stripe necrosis virus and its fungus vector in South America. *European Journal of Plant Pathology* 105, 643-650.
- Ward, E. and Adams, M. J. (1998). Analysis of ribosomal DNA sequences of *Polymyxa* species and related fungi and the development of genus- and species- specific PCR primers. *Mycological Research* 102, 965-974.
- White, T.J., Bruns T., Lee, S. and Taylor, J. (1990). Amplification and direct sequencing of fungal ribosomal RNA genes for phylogenetics. In "*PCR protocols. A Guide to Methods and Applications*" (M. A. Innis, D. H. Gelfand, J. J. Sninsky and T. J. White, Eds), pp. 315-322. Academic Press: San Diego, U.S.A.

THE USE OF LOW ALTITUDE AERIAL PHOTOGRAPHY AND REMOTE SENSING TO STUDY THE SPATIAL DISTRIBUTION OF SOILBORNE VIRUSES.

P. Delfosse¹, B. Gérard¹, A.S. Reddy², S. Schnock³, A. Legrève³ and C Bragard³

¹ICRISAT BP 12 404, Niamey, Niger, ²ICRISAT Patancheru, 502 324, Andhra Pradesh, India,

³Unité de Phytopathologie, Croix du Sud, 2bte 3, B-1348 Louvain-la-Neuve, Belgium.

Summary

Viruses with fungal vectors have typical patchy distribution in the field. Their soilborne vectors comprise the genera *Polymyxa*, *Spongospora* and *Olpidium*. A similar situation exists with nematode transmitted viruses. *Peanut clump virus* (PCV) was identified as one of the agents responsible for crop growth variability in groundnut crops in the Sahel. Low altitude aerial photography and remote sensing have been used in the past to study this variability at field scale. The spatial distribution of PCV and an unidentified virus with isometric particles was studied in Niger during the 2000 and 2001 rainy season. The work presented here links the image analysis of aerial photographs, NDVI measurements recorded with a prototype radiometer coupled with a differential GPS, ELISA and yield data. The results showed a high correlation between above ground groundnut biomass and vegetation indices derived both from aerial photographs and radiometer. The main symptom caused by PCV and the new virus was a strong growth reduction in groundnut. The remote sensing tools proved extremely useful to identify reduction in plant mass and have a potential to ease and hasten mapping of disease patches at low cost.

Introduction

Spatial variation of crop growth over short distance is a constraint to pearl millet (*Pennisetum glaucum*) and groundnut (*Arachis hypogaea*) production in most sandy soils of the West African Sahel (Stein *et al.*, 1997; Subrahmanyam *et al.*, 1993). There were several attempts to explain the cause-and-effect relationship between the short distance differences in crop yield and soil chemical and physical properties or changes in meso-topography (Manu *et al.*, 1996). Other studies looked at a pathological origin to explain this spatial microvariability (Subrahmanyam *et al.*, 1993) and *Peanut clump virus* and nematodes were found to be involved in the spatial variability of groundnut growth. Digital analysis of low altitude aerial photography (Buerkert *et al.*, 1996) and the use of a GPS-based radiometer (Lawrence *et al.*, 2000) were found to be simple non-destructive methods to study the spatial variability in pearl millet growth in the Sahel. PCV and an undescribed virus with isometric particles, possibly vectored by nematodes and tentatively named *Peanut dwarf virus* (PDV) (Delfosse *et al.*, unpubl.) were found to occur on the ICRISAT farm at Sadoré, Niger. Since both viruses cause a severe reduction in crop growth, the low-altitude aerial photography and measurement of vegetation index with a GPS-based radiometer were evaluated to ease and hasten the mapping of the diseases.

Materials and Methods

Experimental fields

The field 3B (1.16 ha) of the ICRISAT Sahelian Centre farm at Sadoré, Niger, was sown with groundnut (cv. UGA-2) intercropped with pearl millet (Sadoré local landrace) on 28 June 2001 with a 0.75 m distance between lines. It was divided according to a 3 x 3 m grid into 1296 square plots of 9m² each containing 2 rows of groundnut bordered by two rows of millet. At harvest the dry yield components were measured for both the crops. The field 6F2 was sown on

the 30 June 2000 with four groundnut cultivars (55-437, TS 32-1, Fleur 11, UGA-2). After radiometric measurements made on 30 individual plants for each cultivar, the aerial dry matter was measured for each plant.

Aerial photography

True color 35 mm low-altitude (50-500 m) aerial photographs were taken approximately two months after sowing using a Zeppelin-shape balloon or a 4m² multi-flare kite as described by Buerkert *et al.* (1996). After standard processing, the Kodak GOLD 100 ISO color negatives were digitized at a 4000 dpi resolution using a 35 mm CanonScan FS-4000US scanner. The image was geometrically rectified and georeferenced according to ground control points using the Image Wrap extension for ArcView®. All geographic information was projected in UTM31N coordinate system to allow spatial analysis in metric units (Gérard & Buerkert, 2001).

Radiometer measurements

During the 2000 rainy season, radiometric measurements were taken 60 DAS at 0.5m above soil surface over 30 individual plants showing various size for each of the 4 cultivars grown in field 6F2. The electronic equipment and the equations used, were described by Lawrence *et al.* (2000). The normalized difference vegetation index ($NDVI = (NIR-RED) / (NIR+RED)$), where RED and NIR are the reflectances in the red and infrared wavelengths, (Tucker *et al.*, 1985) were adjusted ($NDVI_a$) according to the following equation $NDVI_a = (NDVI - NDVI_s) / (1 - NDVI_s)$, where $NDVI_s$ is the NDVI measurement of bare soil.

ELISA

A homologous antiserum to *PDV* was produced in a rabbit using purified virus multiplied in *Phaseolus vulgaris*. The ALP based, double antibody system of ELISA was used for routine detection in groundnut. The entire field 3B was sampled 3 months after sowing according to a 3x3 m grid representing a total of 1296 composite samples of 10 plants each. One composite sample was used for each well of the ELISA plate. Since 14 ELISA plates were used, the A_{405} values were calculated as percentages of the positive controls.

Results

Radiometer measurements.

Regression analysis $\{\log(Y)=A+B\cdot\log(X)\}$ after grouping data by groundnut cultivar showed that the aerial dry matter was highly correlated with $NDVI_a$. (R^2 ranged from 0.69 for UGA-2 to 0.92 for TS 32-1). Differences between cultivars were observed. The cultivar UGA-2 has a spreading port, a long duration cycle and plants darker green in color than other cv. It showed relatively high $NDVI_a$ values for plants showing relatively smaller aerial dry matter than those of the other cultivars.

Aerial photography

The georeferenced aerial photography of the field 3B and image analysis allowed the mapping of the crop growth spatial variability for both the crop (Fig.2).

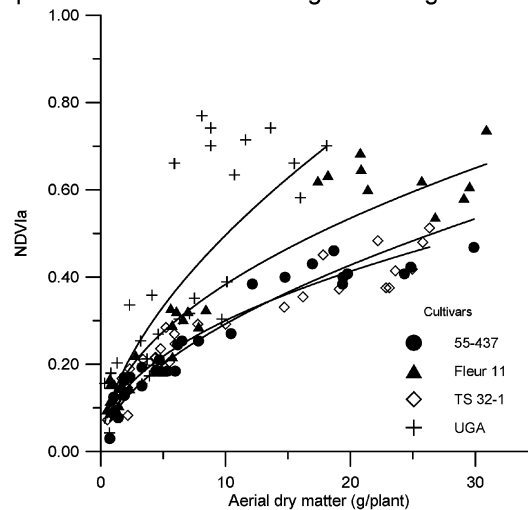

Fig. 1. Relationship between the adjusted vegetation index ($NDVI_a$) measured by the home-made radiometer and the aerial dry weight of 4 groundnut cultivars (field 6F2, rainy season 2000)

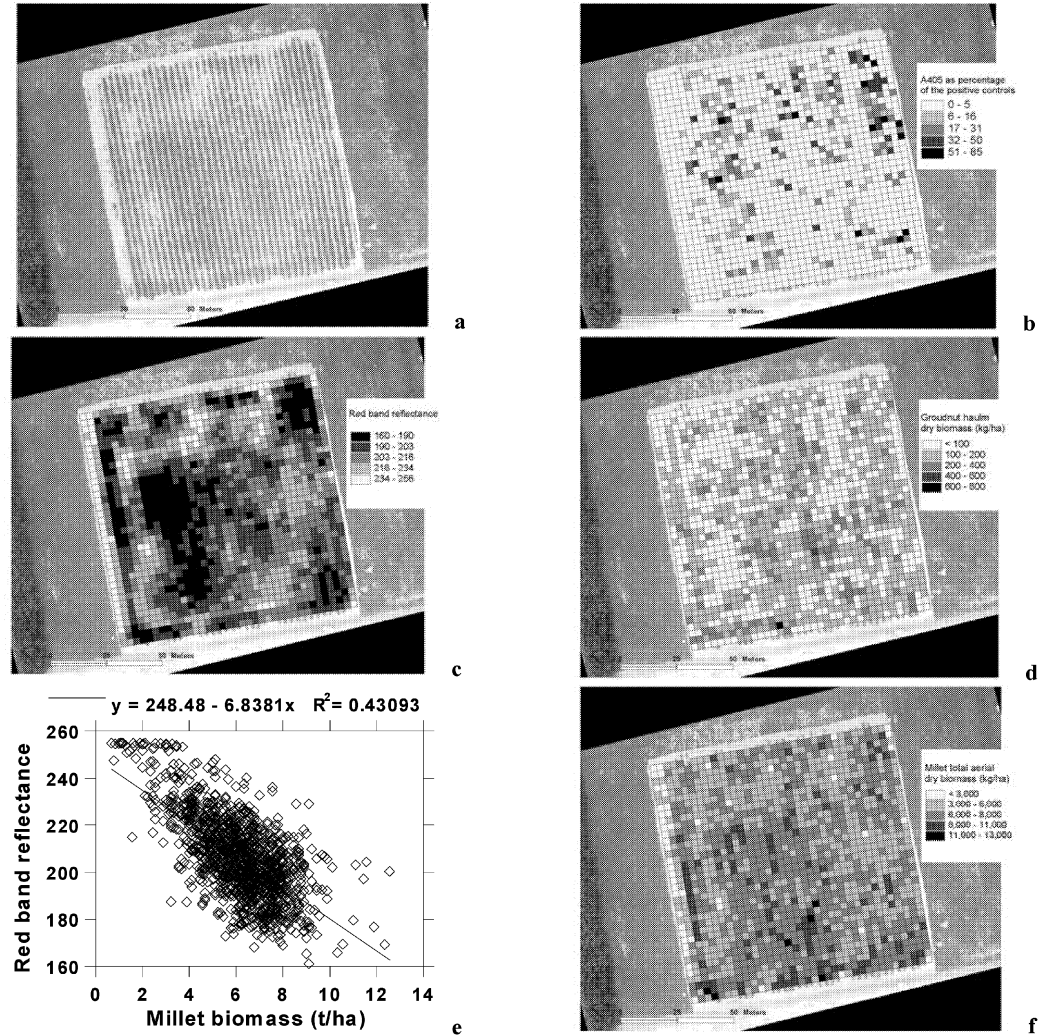

Fig. 2. Aerial photograph of field 3B taken 2 months after sowing in September 2001 (a), maps designed in ArcView showing: (b) the *PDV* distribution obtain by ELISA tests (A_{405} as percentages of the positive controls), (c) the red band reflectance derived from the color photograph, (d) the groundnut haulm dry biomass (kg/ha) and, (e) the relationship between the aerial millet biomass and the red band reflectance values. All destructive and non-destructive values were aggregated on a 3x3 m grid (f) the pearl millet aerial dry biomass (kg/ha).

The best correlation was observed between the red band reflectance and pearl millet aerial biomass (Fig. 2e). Usually the areas showing poor millet growth also showed poor groundnut growth (Fig. 2d and 2f). *PDV* presence assessed by the ELISA tests was mapped on the field grid. The areas with high A_{405} values corresponded to some extent to the areas showing poor groundnut pod yield (Fig. 2b and 2d). A majority (78%) of plots were free of virus infection ($A_{405}=0.140\pm 0.040$, less or equal to 5% of the positive control $A_{405}=2.850\pm 0.300$) and plots showing high A_{405} values were generally not high yielding plots (Fig. 3). Among the 44 plots showing a A_{405} at least equal to 30 % of the positive control there was no obvious correlation between A_{405} and groundnut yield (Fig.4).

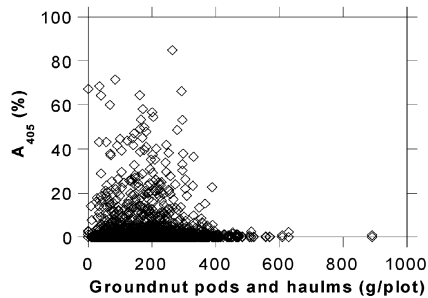

Fig. 3. Relationship between A_{405} (%) and groundnut pods and haulms dry matter for 1296 plots of 9m² each (field 3B, 2001)

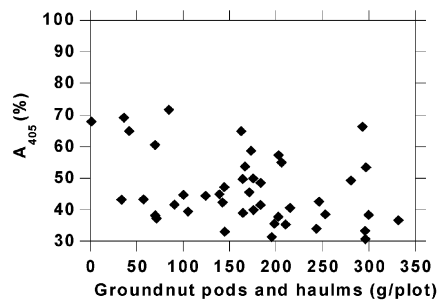

Fig.4. Relationship between A_{405} (%) and groundnut pods and haulms dry matter for 44 plots of 9m² each showing A_{405} values of at least 30% of the positive control.

Discussion

The aerial photography proved extremely useful to identify the reduction in plant mass for both groundnut and pearl millet crops. The radiometric measurements allowed a good estimation of the aerial plant biomass and, if coupled to a differential GPS, should therefore be useful to map growth reduction caused by viruses such as *PCV* and *PDV*. On the other hand, the image analysis of field 3B indicated that growth reduction cannot be explained only by the presence of *PDV*. This field showed a negligible incidence of *PCV* (5 plants in 2000) and seeing the correspondence between millet and groundnut growth it is highly probable that poor soil fertility is also responsible for the poor crop development. Intercropping did not facilitate specific analysis for each species and aggregation on a larger grid should reduce the variability due to imprecision when georeferencing the image. In the near future, the remote sensing tools will be used to map *PCV* disease which occur with high incidence in Maradi area in Niger.

Acknowledgements.

This research was funded by DGCI, Brussels, Belgium. The authors are grateful to Souleymane Adamou, Amadou Mounkaila, Tahirou Saley and Zakari Soumana, for their technical assistance

References

- Buerkert, A., Mahler E., Marschner, H. 1996. Soil productivity management and plant growth in the Sahel: potential of an aerial monitoring technique. *Plant and Soil* 180:29-38
- Gérard, B., Buerkert, A. 2001. Estimation of spatial variability in pearl millet growth with non-destructive methods. *Expl. Agric* 37:373-389.
- Lawrence, P.R., Gérard, B., Moreau C., Lhérieau, F., and Buerkert, A. 2000. Design and testing of a GPS-based reflectometer for precision mapping of pearl millet total dry matter in the Sahel. *Agronomy Journal* 92: 1086-1095.
- Manu, A., Pfordresher, A.A., Geiger, S.C., Wilding, L.P., Hossner, L.R. 1996. Soil parameters related to crop growth variability in Western Niger, West Africa. *Soil Science Society of America Journal* 60 (1): 283-288.
- Stein, A., Brouwer, J., and Bouma, J. 1997. Methods in comparing spatial variability patterns of millet yield and soil data. *Soil Science Society of America Journal* 61: 861-870.
- Subrahmanyam, P., Ndunguru, B.J., Sharma, S.B., Sahrawat K.L., Greenberg, D.C., and Van Riel, H. 1993. Etiology of crop growth variability in groundnut in Niger. *Plant and soil* 150: 139-146.

ANALYSIS OF SOILBORNE WHEAT MOSAIC VIRUS 37K AND COAT PROTEIN: VIRUS MOVEMENT AND TRANSGENIC RESISTANCE.

H. An¹, A. Guenzi² and J. Verchot-Lubicz¹

Oklahoma State University, ¹Department of Entomology and Plant Pathology, ²Department of Plant and Soil Sciences, Stillwater, OK 74078. Corresponding author: Jeanmarie Verchot-Lubicz. Verchot@okstate.edu.

Abstract

In recent years, soilborne plant viruses have played a significant role in advancing research into mechanisms of plasmodesmata transport, gene silencing, and engineered resistance to plant pathogens. The potential use of pathogen-derived resistance to control soilborne viruses is currently being explored in several laboratories. The mechanism for movement of furoviruses has not been explored until now. In this report initial experiments are described, using the furovirus *Soilborne wheat mosaic virus* 37K protein and coat protein to explore the requirements for virus movement and to determine the effectiveness of pathogen derived resistance as a means to control disease.

Introduction

Soilborne wheat mosaic virus (SBWMV) is the type species of the *Furovirus* genus (Mayo, 1999). SBWMV is a rigid rod-shaped virus that has a positive-strand bipartite RNA genome and is transmitted by *Polymyxa graminis*, which is a soil-inhabiting plasmodiophorid.

SBWMV RNA1 is 7.1 kb and encodes three proteins. Two proteins of 150-kDa and 209-kDa are produced from overlapping open reading frames (ORF) and share amino acid sequence homology with the *Tobacco mosaic virus* (TMV) replicase (Shirako, 1993). The 3' proximal ORF of RNA1 encodes a 37-kDa protein that shares amino acid sequence similarity with the dianthovirus movement protein (Shirako and Wilson, 1993). SBWMV RNA2 is approximately 3.6 kb and encodes four proteins. The 5' proximal ORF of RNA2 encodes a 28-kDa protein that is produced from a non-AUG start codon (Shirako, 1998) and its function is not known. The 28-kDa protein ORF overlaps a downstream ORF that encodes the 19-kDa coat protein (CP). The CP ORF has an opal translational termination codon. Readthrough of this codon produces an 84-kDa protein (Hsu, 1985), called the readthrough domain (RT), that is required for plasmodiophorid transmission of the virus ((Koenig et al., 1997; Tamada and Kusume, 1991). The 3' proximal ORF of RNA2 encodes a 19-kDa protein and its function is not known.

The SBWMV 37K protein has been assigned to the 30K superfamily of viral movement proteins based on amino acid sequence alignments (Melcher, 2000). In a previous study, consensus movement protein sequences were generated for each virus family and compared in a multiple sequence alignment to discover conserved amino acid sequence motifs and secondary structural elements. In this study experiments were conducted to determine if the 37K protein, like other members of the 30K superfamily, has the ability to induce plasmodesmata gating and move cell-to-cell in host plants. Transgenic wheat plants expressing the 37K protein or CP were prepared and preliminary data suggests these plants may be resistant to virus infection.

Materials and Methods

Plasmid constructs.

Four plasmids, pGFP, pGFP:37K, pCP:GFP, and pGFP:RT, were prepared. The plasmid pAHC25 contains two expression cassettes: one contains the *bar* gene fused to the *ubi*

promoter and terminator, and the second contains the *uidA* gene also fused to the *ubi* promoter and terminator.

Plant Material and Biolistic Bombardment.

Leaves of the hard red winter wheat (cv. Vona), and tobacco (cv. Petit Havana) were used for these experiments. Leaves were bombarded with 10 μ g plasmids mixed with 1 mg of 1 μ m gold particles as described previously (Yang et al., 2000). Leaves were observed 1 and 3 day post bombardment (dpb) using epifluorescence microscopy to detect GFP expression (Yang et al., 2000).

Transformation of wheat embryos and regeneration of transgenic plants

Immature embryos of the wheat variety Bobwhite were cultured for 5 days in the dark on a callus induction medium (CIM) containing 4.3g l⁻¹MS salts, 1X MS Vitamins, 2% Sucrose, 1.5mg l⁻¹ 2,4-D, 0.150 g l⁻¹ L-asparagine, and 2.5g l⁻¹ Phytigel (all chemicals from Sigma, St. Louis, Mo) before microprojectile bombardment. Osmotic treatment before and after bombardment was performed on CIM medium with 0.4 M mannitol. The PDS-1000/He apparatus (BioRad, Hercules, CA) was used for biolistic transformation. Following the bombardment, immature embryos were transferred to callus selection medium (CIM medium with 1.5 mg l⁻¹ bialaphos) for 5-6 weeks at 20°C in the dark. Bialaphos-resistant callus was transferred to shoot initiation medium (which is MS medium containing 2% sucrose, 0.5mg l⁻¹ Dicamba and 1.5 mg l⁻¹ bialaphos and 2.5g l⁻¹ Phytigel) for 3-4 weeks at 20°C under a 16 h photoperiod. The regenerated shoots were transferred to Magenta boxes with root induction medium (containing half-strength CIM medium and lacking 2,4-D) for 4-5 weeks at 20°C under the above light conditions. Plantlets were transferred from root induction medium to greenhouse. T0 plants were self-pollinated and grown to maturity. T1, T2 and T3 seeds were collected from self-pollinated T0, T1, and T2 plants, respectively.

Results and Discussion

Cell-to-cell movement of SBWMV proteins

To determine if the SBWMV 37K, CP, or RT domains can traffic between adjacent cells, GFP was fused to each open reading frame and inserted into pAHC25 plasmids. The *ubi* promoter drives expression of the fused genes. The plasmid pGFP:37K contains GFP fused to the 5' end of the SBWMV 37K gene. In the plasmid pCP:GFP, GFP was fused to the 3' end of the CP gene, replacing the coding sequence for the RT domain. In the plasmid pGFP:RT, GFP was fused to the 5' end of the RT domain replacing the CP open reading frame. Plasmids containing only GFP (pGFP) were also prepared.

These plasmids were delivered to single epidermal cells of winter wheat (cv. Vona) or tobacco leaves by biolistic bombardment. Epifluorescence microscopy was used to study protein cell-to-cell movement at 1 and 3 dpb. In wheat and tobacco leaves bombarded with pGFP plasmids, GFP accumulated primarily in single epidermal cells (Table 1). On rare occasions GFP was detected in two adjacent cells. Similar background levels were reported in related studies, and might occur on occasions when plasmids were delivered to neighboring cells (Itaya, 1997; Yang, 2000).

Between 24 and 30% of sites (at 1 and 3 dpb) containing GFP:37K were multiple cell clusters in winter wheat and those percentages were significantly greater than the proportions of sites containing GFP in adjacent cells at 1 and 3 dpb. GFP:37K containing cell clusters ranged in size between 2 to 8 cells (Table 1). The proportion of sites containing fluorescence in multiple cell clusters increased over time indicating that protein movement occurred during the three-day observation period. In tobacco leaves, GFP:37K accumulated primarily in single cells, indicating that cell-to-cell movement of GFP:37K was host specific.

Cell-to-cell movement of CP:GFP or GFP:RT was not observed. CP:GFP and GFP:RT were

detected primarily in single cells in wheat and tobacco leaves at 1 and 3dpb (Table 1).

These results suggest that the SBWMV 37K protein, like other members of the 30K superfamily, have the ability to induce plasmodesmata gating and move cell-to-cell in host plants.

Table 1. Cell-to-cell movement of GFP, GFP:37K, CP:GFP, and GFP:RT in tobacco and wheat leaves following PDS1000/He plasmid delivery

Plants	Proportion of sites containing GFP activity in multiple cells ^a			
	GFP	GFP:37K	CP:GFP	GFP:RT
Tobacco				
1dpb	11.4% (1/88)	0.0% (0/42)	3.3% (2/60)	0.0% (0/44)
3dpb	2.0% (2/96)	0.0 (0/41)	3.7 (2/54)	0.0 (0/44)
Winter wheat				
1dpb	6.1 (32/523)	24.2 (62/256)	7.0 (7/100)	6.8 (9/132)
3dpb	6.0 (32/526)	30.0 (87/290)	7.0 (7/100)	6.2 (8/130)

^a Percentages of fluorescent cell clusters observed 1 and 3 dpb in tobacco and wheat leaves are indicated. "Cell clusters" are defined as two or more adjacent cells. The total numbers of cell clusters relative to the total number of fluorescent sites are in parentheses. The total sites indicated were obtained from two to six leaves and were bombarded with pAHC25-GFP, -GFP:37K, -CP:GFP, or -GFP:RT.

Transgenic resistance to SBWMV

Control of soilborne viruses in agricultural fields has relied primarily on using chemical nematicides or fungicides that reduce the vector populations but are not highly effective in limiting virus infection. Soil application of agrochemicals is now being restricted in many countries throughout Europe and the USA leaving farmers few alternatives to control soilborne viral diseases. One option is to develop improved varieties by incorporating new sources of natural or engineered resistance into breeding programs. Within the last decade studies have been conducted to determine whether pathogen-derived resistance could allow control of soilborne viruses.

Transgenic wheat expressing SBWMV genes were prepared and tested for virus resistance. Transgenic wheat expressing CP:GFP or 37K open reading frames were prepared. Regenerated plants were tested by Southern analysis and by PCR to detect the transgene. RT-PCR and Western analysis was used to confirm transgene expression primarily in CP:GFP and 37K transgenic plants. In this study, the transformation frequencies in wheat were approximately 2-3%. Transgenic lines expressing CP:GFP were labeled 103-112 and lines expressing 37K were labeled 301-316 (Table 2).

T2 transgenic plants were tested for virus resistance. Plants were inoculated with purified virus and grown for 4 weeks. Plants were scored for the presence or absence of symptoms. In all cases symptoms were reduced in transgenic plants. Leaf extracts were analyzed for the presence of virus. Transgenic plants that were resistant to SBWMV were identified (Table 2).

The data presented in this study are still preliminary and further research is needed to determine whether resistance is RNA- or protein-mediated. We do not yet know if resistance is effective under field conditions. Research is currently underway to explore the effectiveness of pathogen-derived resistance following root and foliar inoculation of the virus.

Table 2. Western blot analysis of CP:GFP or 37K transgenic wheat 4 weeks post inoculation with SBWMV

CP:GFP transgenic plants	Infected plants	37K plants	Infected plants
103	0/10	301	0/20
104	0/5	302	0/7
105	5/19	305	0/5
106	0/10	306	0/6
108	0/10	308	0/6
109	6/10	310	0/7
110	2/9	311	0/12
111	0/10	312	0/15
112	0/10	313	0/13
Nontransgenic	7/10	314	0/23
		315	0/8
		316	0/5

T1 transgenic plants were inoculated with SBWMV and grown for 4 weeks. Transgenic lines 103-112 expressing GFP:CP. Transgenic lines 301-316 express 37K. Western analysis was conducted to confirm the presence or absence of virus. Proportions indicate the number of plants that were SBWMV infected relative to the total number of plants inoculated.

References

- Hsu, Y. H. and Brakke, M.K. (1985). Cell-free translation of *Soilborne wheat mosaic virus* RNAs. *Virology* 143, 272-279.
- Itaya, A., Hickman, H., Bao, Y., Nelson, R., and Ding, B. (1997). Cell-to-cell trafficking of *Cucumber mosaic virus* movement protein: Green fluorescent protein fusion produced by biolistic gene bombardment in tobacco. *Plant J.* 12, 1223-1230.
- Koenig, R., Commandeur, U., Loss, S., Beier, C., Kaufmann, A., Lesemann, D.-E. (1997). *Beet soilborne virus* RNA3: a further example of heterogeneity of the gene content of *Furovirus* genomes and of triple gene block-carrying RNAs. *Virology* 216, 202-207.
- Mayo, M. A. (1999). Developments in plant virus taxonomy since the publication of the 6th ICTV report. *Arch. Virol.* 144, 1659-1666.
- Melcher, U. (2000). The '30K' superfamily of viral movement proteins. *J. Gen. Virol.* 81, 257-266.
- Shirako, Y. (1998). Non-AUG translation initiation in a plant RNA virus: a forty-amino-acid extension is added to the N terminus of the *Soilborne wheat mosaic virus* capsid protein. *J. Virology* 72, 1677-1682.
- Shirako, Y., and Wilson, T.M.A. (1993). Complete nucleotide sequence and organization of the bipartite RNA genome of *Soilborne wheat mosaic virus*. *Virology* 195, 16-32.
- Tamada, T., and Kusume, T. (1991). Evidence that the 75K readthrough protein of *Beet necrotic yellow vein virus* RNA-2 is essential for transmission by the fungus *Polymyxa betae*. *J. Gen. Virol.* 72, 1497-1504.
- Yang, Y., Ding, B., Baulcombe, D.C. and Verchot, J. (2000). Cell-to-cell movement of the 25K protein of *Potato virus X* is regulated by three other viral proteins. *Molec. Plant Microbe Interact* 13, 599-605.

REACTIONS TO SBWMV OF DURUM WHEAT CULTIVARS GROWN DURING 2000/2001 IN NORTHERN ITALY

V. Vallega¹, C. Rubies Autonell² and C. Ratti²

¹Istituto Sperimentale per la Cerealicoltura, Via Cassia 176, 00191 Rome, Italy, ²DiSTA, University of Bologna, Via Filippo Re 8, 40126 Bologna

Summary

Thirty-one durum wheat cultivars were grown in a severely SBWMV-infested field near Bologna, and evaluated for resistance to SBWMV on the basis of symptom severity, DAS-ELISA readings, and agronomic performance. Cultivars Colorado, Neodur and Provenzal, expressed very mild symptoms, gave null ELISA values, and produced relatively high grain yields. Most other cultivars proved susceptible or moderately susceptible. Regression analysis indicated that the five cvs. with the highest disease scores suffered grain losses attributable to SBWMV of about 48% and severe reductions in plant height (17%), test weight (4 %) and 1000-kernel weight (15%).

Introduction

Soilborne wheat mosaic virus (SBWMV) is widespread in Italy (Canova and Quaglia 1960; Rubies-Autonell and Vallega 1985; Vallega and Rubies-Autonell 1989; Ratti et al. 2002), where it may cause grain yield reductions of about 50-70% (Rubies et al.; Vallega and Rubies-Autonell 1985; Vallega et al. 1997, 1999a, 1999b). SBWMV can be controlled only by growing genetically resistant cvs.

According to some authors the SBWMV-like viruses thus far identified in Italy and other countries in Europe are distinct from the SBWMV originally described in the U.S., and should be denominated either *European wheat mosaic furovirus* or *Soilborne cereal mosaic furovirus* (Diao et al., 1999; Koenig et al., 1999; Koenig and Huth, 2000); other authors opine that the differences observed between isolates do not warrant a change in nomenclature (Shirako et al 2000).

Materials and Methods

The trial comprised 31 cultivars of durum wheat (*Triticum durum* Desf.) sown October 26 (2000) in a field with SBWMV situated near Minerbio, in northern Italy. Only twelve of these wheats had been previously tested for SBWMV-resistance. Cultivars were grown in plots of 10-m² distributed according to a randomized-block design with three replicates. Symptom severity was evaluated using a 0-4 scale, where 0.0-1.0 = slight or no symptoms; 1.1-2.0 = mild mottling and stunting; 2.1-3.0 = mottling and stunting; and 3.1-4.0 = severe mottling and stunting, with virus-killed plants. Symptom scores, assigned on March 5 and March 21, were averaged for presentation and computations. Agronomic performance was evaluated in terms of grain yield, 1000-kernel weight, test weight and plant height at maturity. Ten plants were collected from each plot March 21 to perform DAS-ELISA as described in Vallega et al. (1999a). Extracts were prepared with the distal half portion of the youngest leaf of each plant.

Linear regression equations between disease severity and each of the plant characters considered were used to estimate the effects of SBWMV. Estimates for test weight and 1000-kernel weight reduction should be considered merely indicative in that correlations with these two seed characteristics were statistically not significant; indeed, an epidemic of yellow rust

(*Puccinia striiformis* f. sp. *tritici*) differentially affected the performance of the wheat assayed, especially grain filling.

Results and Discussion

None of the 31 durum cvs. analysed was symptomless (Table 1), and only Colorado, Neodur and Provenzal gave null ELISA values. These three wheats expressed very mild symptoms (disease score = 0.6) and produced relatively high grain yields (4.53 – 5.53 t/ha); cv. Neodur had proven highly resistant to SBWMV in previous trials (Vallega et al. 1999a, 1999b). Cultivars Lloyd, Nefer and Vitron expressed mild symptoms and produced high grain yields but showed a somewhat lesser degree of resistance in terms of foliar virus concentration (ELISA values between 0.100 and 0.201); cv. Lloyd had shown moderately high levels of resistance to SBWMV in a previous trial (Vallega et al. 1999b).

The most severe symptoms were recorded for cvs. Vesuvio (mean disease score = 3.0), Cirillo (2.8), Simeto (2.8), Claudio (2.3) and Portorico (2.0). As expected, these wheats had high ELISA values (= 1.049) and produced relatively poor yields (1.15 – 3.82 t/ha).

Correlations between either ELISA values or symptom severity scores and each of the plant characters considered were mostly significant (Table 1, Figs. 1 and 2), but markedly lower than in previous experiments (Rubies et al. 2002; Vallega and Rubies-Autonell 1985; Vallega et al. 1997, 1999a, 1999b), most probably because of the confounding effects of the concomitant yellow rust epidemic. The correlation between ELISA value and disease severity (Fig. 2), as expected, was statistically highly significant (0.630**).

Table 1. Simple correlation coefficients between disease severity, ELISA values and various plant characters, for 31 cultivars of durum wheat grown in a field with SBWMV near Bologna, Italy, in 2000-2001.

	Mean	Range	Disease severity	ELISA values
Grain yield (t/ha)	4.26	1.15 - 5.97	- 0.630**	- 0.570**
Test weight (kg/hl)	76.2	68.4 - 81.7	- 0.303	- 0.371*
Plant height (cm)	89	71 - 102	- 0.665**	- 0.404*
1000-kernel weight (g)	39.2	29.1 - 55.7	- 0.303	- 0.079
Disease severity (0-4)	1.1	0.1 - 3.0	-	0.762**
ELISA values	0.585	0.000 - 1.159	0.762**	-

* = significant at P = 0.05; ** = significant at P = 0.01*

Table 2. Estimated mean effects of SBWMV on durum wheat cultivars with different disease severity grown in a field near Bologna, Italy during 2000-2001.

Disease severity	Grain yield loss		Test weight reduction		Plant height reduction		1000-kernel weight reduction	
	Actual (t/ha)	%	Actual (kg/hl)	%	Actual (cm)	%	Actual (g)	%
0 - 1	0.49	10 %	1.0	1 %	3	3 %	1.2	3 %
1.1 - 2	1.09	21 %	1.3	2 %	7	7 %	2.0	5 %
2.1 - 3	2.49	48 %	3.3	4 %	16	17 %	6.2	15 %

Figure 1: Relationship between disease severity (scale 0 - 4) and grain yield observed for 31 cvs. of durum wheat in a field with SBWMV near Bologna, Italy, in 2000-2001).

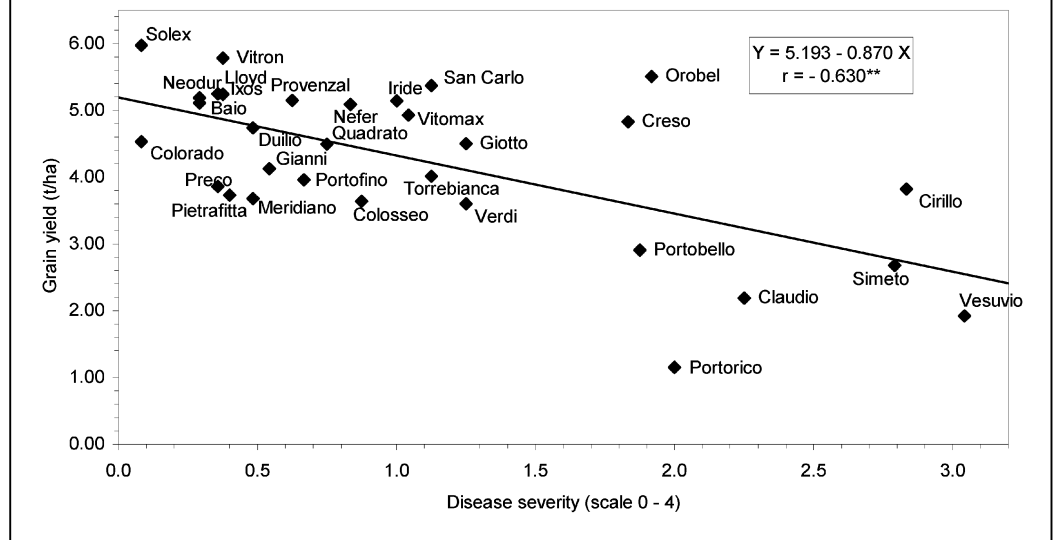
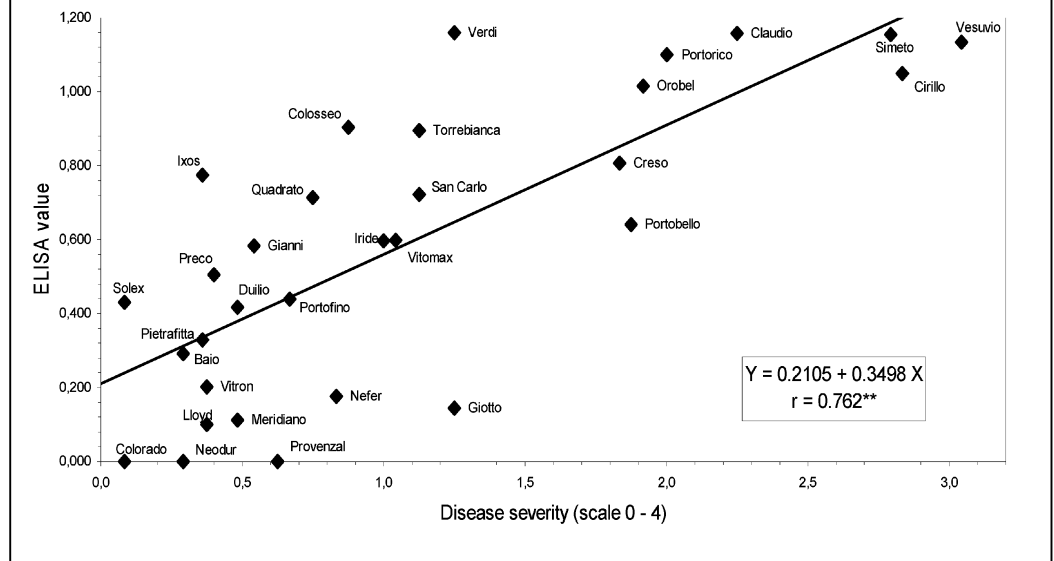

Figure 2: Relationship between ELISA values and disease severity (scale 0 - 4) observed for 31 cvs. of durum wheat in a field with SBWMV near Bologna, Italy, in 2000-2001).



Linear regression equations between disease severity and each of the plant characters considered showed that the five cultivars with disease scores equal or above 2.0 (Table 2) suffered grain yield losses of about 48% and noticeable reductions in plant height (15%), test weight (4%) and 1000-kernel weight (17%). Cultivars with relatively mild symptoms (1.1 – 2.0) also suffered grain yield and 1000-kernel weight reductions, of about 21% and 5%, respectively.

Among the durum wheat cvs. tested in this and previous experiments (Vallega et al. 1997, 1999a, 1999b), only two have been rated as highly resistant to SBWMV, i.e. cvs. Ionio (not included in this experiment) and Neodur.

References

- Canova, A. and Quaglia, A. (1960). Il mosaico del frumento. *Inf. Fitopatol.* 10, 206-208.
- Diao, A.P., Chen J.P., Ye R., Zheng T., Yu S.Q., Antoniw J.F. and Adams M.J. (1999). Complete sequence and genome properties of *Chinese wheat mosaic virus*, a new furovirus from China. *J. Gen. Virol.* 80: 1141-11451.
- Koenig, R, Pleij C.W.A. and Huth W. (1999). Molecular characterization of a new furovirus mainly infecting rye. *Arch. Virol.* 144: 2125-2140.
- Koenig, R., and Huth W. (2000). Soilborne rye mosaic and *European wheat mosaic virus*: two names for a furovirus with variable genome properties which is widely distributed in several cereal crops in Europe. *Arch. Virol.* 145: 689-697.
- Ratti, C., Rubies-Autonell, C., Canova A., Montanari O., and Vallega V. (2002). Caratterizzazione molecolare di isolati italiani del mosaico comune del frumento (SBWMV). In "Proc. Giornate Fitopatologiche 2002" (A. Brunelli, A. Canova Eds), Vol II, pp. 585-592.
- Rubies-Autonell, C. and Vallega, V. (1985). Il mosaico comune del frumento riscontrato anche nel Lazio. *Inf. Fitopat.* 35, 39-42.
- Rubies-Autonell, C., Vallega, V. and Ratti, C. (2002). Reactions to SBWMV of cultivars of common wheat in northern Italy during 1996-97. *Z. PflKrankh. PflSchutz.* (in press).
- Shirako, Y., Suzuki N., French R.C. (2000). Similarity and divergence among viruses in the genus Furovirus. *Virology*, 270, 201-207.
- Vallega, V. and Rubies-Autonell, C. (1989). Ulteriori indagini sulla diffusione del virus del mosaico comune in Italia. *Inf. Fitopat.* 39, 57-58.
- Vallega, V. and Rubies-Autonell, C. (1985). Reactions of Italian *Triticum durum* cultivars to *Soilborne wheat mosaic*. *Plant Dis.* 69, 64-66.
- Vallega, V., Rubies-Autonell C., Ratti C., and Turina, M. (1997). Reactions of 36 common wheat cultivars to *Soilborne wheat mosaic virus* during 1995-1996. In "Proc. 10th Cong. Medit. Phytopath. Union" (ed. Soc. Française de Phytopat.), pp. 627-631.
- Vallega, V., Rubies-Autonell, C., Turina M., Ratti C., and Contoli, S. (1999a). Reactions of durum wheat cultivars to infections by SBWMV grown in northern Italy during 1995-96. *Z. PflKrankh. PflSchutz.* 106, 284-290.
- Vallega, V., Rubies-Autonell C., Ratti C., Turina, M., and Contoli, S. (1999b). Reactions of durum wheat (*Triticum durum* Desf.) cultivars (cvs) to *Soilborne wheat mosaic furovirus* (SBWMV) in northern Italy during 1996-97. In "Proc. Fourth Symp. International Working Group on Plant Viruses with Fungal Vectors" (J.L. Sherwood and C.M. Rush Eds), pp. 131-134.

INTERACTIONS BETWEEN BEET NECROTIC YELLOW VEIN VIRUS AND BEET SOILBORNE MOSAIC VIRUS AND THEIR EFFECT ON VIRUS LEVELS IN SUGAR BEET

G. C. Wisler¹, R. T. Lewellen², J. L. Sears², H.-Y. Liu², J. W. Wasson² and W. M. Wintermantel²

¹University of Florida, Department of Plant Pathology, P.O. Box 110680, Gainesville, FL 32611,

²USDA-ARS, 1636 E. Alisal St., Salinas, CA 93905

Summary

Soils naturally infested with cultures of aviruliferous *Polymyxa betae* and viruliferous *P. betae* carrying two sugar beet benyviruses BNYVV and BSBMV, alone and in combination, were compared to non-infested soil for their effects on virus content. Two sugar beet varieties were used: a diploid (*Rzrz*) that carries resistance to rhizomania caused by BNYVV, and a triploid rhizomania-susceptible variety (*rzrzrz*). The *Rz* resistance gene to BNYVV did not confer resistance to BSBMV. Titers of BSBMV were significantly higher in single infections than in mixed infections with BNYVV, in both the rhizomania-resistant and susceptible varieties. In contrast, titers of BNYVV were high (8 to 14 times the healthy mean) in single and in mixed infections in the rhizomania-susceptible variety, but were low (ca. three times the healthy mean) in the rhizomania-resistant variety. Therefore, in the absence of BNYVV, titers of BSBMV are high, regardless of the resistance genotype. However, in the presence of BNYVV, titers of BSBMV are low in both varieties, with absorbance (A_{405nm}) readings similar to those of plants grown in non-infested soils. BNYVV may either out-compete or suppress BSBMV in mixed infections, even in rhizomania-resistant varieties in which titers of BNYVV are extremely low.

Introduction

Beet necrotic yellow vein virus (BNYVV) and *Beet soilborne mosaic virus* (BSBMV) are members of the genus *Benyvirus* in the *Furoviridae* (13,15). Both viruses infect members of the *Chenopodiaceae*, most notably sugarbeet (*Beta vulgaris* L.), and both are transmitted by *Polymyxa betae* (1,2). BNYVV has been shown to be the cause of rhizomania (4,12). BSBMV was first described in the United States by Duffus and Liu in 1987 (5), and has been shown to have a sequence similarity to BNYVV that ranged from 30-90% in RNA2 and a genome organization similar to BNYVV (7). Based on these and other studies (17), and the fact that BSBMV does not cause rhizomania, BSBMV is considered to be a distinct member of the genus *Benyvirus*.

Because of the international significance and economic losses caused by BNYVV on sugar beet production, a breeding program has been in place in the U.S. since 1984 (3,8,9,10). A gene that induces resistance to rhizomania in sugar beet (*Rz*) was identified in 1983 from sugar beet and subsequently from wild beet (*B. maritima*) (3,10). Breeding programs have improved rhizomania resistance to a point where, even under conditions of high inoculum (i.e., the San Joaquin Valley, California), yields and sugar production are equal to those of high-yielding, susceptible sugar beet varieties in the absence of rhizomania (Lewellen, unpublished data). Furthermore, the level of resistance is significantly correlated with the dose of the *Rz* allele as measured by (i) root weight, (ii) the rhizomania disease index (DI) rating (from 1-9, where a low DI indicates resistance and lack of symptoms, and a high DI indicates susceptibility and the presence of hairy roots, a wine glass-shaped root and internal necrosis), and (iii) sugar yield. For example, a strong negative correlation was shown between a decreasing dosage of the *Rz* allele and absorbance and the DI rating (*Rzrz*<*Rzrzrz*<*rzrzrz*). However, a positive correlation was shown between a decreasing dosage of the *Rz* allele and root weight (*Rzrz*>*Rzrzrz*>*rzrzrz*) (16). A diploid rhizomania-resistant variety (*Rzrz*) has a lower virus titer and DI rating but a

higher root weight than a triploid resistant variety (*Rzrzrz*), and a susceptible triploid variety (*rzrzrz*). Homozygous resistance (*RzRz*) usually conditions a higher level of resistance than the heterozygous (*Rzrz*) genotype (Lewellen, unpublished data).

In contrast to BNYVV, little is known about the effect of BSBMV on yield and sugar production in sugar beet. The objectives of this study were: (i) to determine if the *Rz* gene confers resistance to BSBMV, and (ii) to determine the effects of BNYVV and BSBMV, alone and in combination, on the relative virus titers in sugar beet. Our goal in this study was to determine the effect of single and mixed infections of benyvirus in naturally infested soils.

Materials and Methods

Methods to test soils for rhizomania have been described by Gerik et al. (6). Soil samples previously identified as being singly infested with BNYVV, BSBMV, or aviruliferous *P. betae* have been increased and stored at 4C for this study. BNYVV-infested soil was taken from the sugar beet fields that had been infested since the late 1980's and consistently used in rhizomania variety trials at the USDA-ARS in Salinas, CA. Tests are routinely made in these rhizomania fields for the presence of BSBMV, and it has never been detected. BSBMV-infested soil was obtained from sugar beet fields in Nebraska and was submitted by Dr. Eric Kerr (University of Nebraska). Aviruliferous, *P. betae*-infested soil was obtained from river sand provided by Dr. Gary D. Franc (University of Wyoming). To increase the quantities of infested soil samples, roots from pot cultures were air dried, homogenized in mortars and pestles, and thoroughly mixed into respective soil samples. Non-infested soil consisted of loamy sand collected from the nearby dry bed of the Salinas River, and that was autoclaved prior to use. A list of computer-generated random numbers was used to determine the placement of each pot on the greenhouse benches for a completely random design. Varieties used in tests 1, 2, and 3 were *Beta4330R* (*Rzrz*; resistant) and *KWS6770* (*rzrzrz*; susceptible).

Test 1 consisted of the following treatments: (1) non-infested soil, (2) BSBMV-infested soil, (3) BNYVV-infested soil and (4) BNYVV- and BSBMV-infested soil, mixed in equal parts. In this test, only the rhizomania-susceptible variety (*KWS6770*) was used. Samples were harvested weekly for 6 weeks starting 2 weeks post emergence of seedlings. Each treatment combination (soil × harvest date) consisted of six pots each for a total of 24 pots weekly.

In tests 2 and 3, aviruliferous *P. betae* was added as a treatment, and a rhizomania-resistant variety (*Beta 4430R*) was also included. In these two tests, each treatment combination (soil × variety × harvest date) consisted of three pots each. Roots from these pots were harvested and tested at weekly intervals for 6 weeks, for a total of 30 pots weekly.

In previous studies (11,14) a clear relationship was obtained between virus concentrations in BNYVV-infected plants and absorbance values with ELISA. A triple antibody sandwich (TAS)-ELISA was developed in collaboration with Agdia, Inc. (Elkhart, IN) that was specific for BNYVV. The double antibody sandwich (DAS)-ELISA test was used to test for BSBMV. Antiserum to BSBMV was provided by H.-Y. Liu. Absorbance readings (A_{405nm}) from the average of paired wells were made with a Bio-Tek EL312e microplate reader (Winooski, VT). All reported ELISA values were for the 2 hr period and represent the ratio of the test sample absorbance at A_{405nm} divided by the absorbance of the healthy sample. Ratios of ≥ 3 times the healthy mean were considered to be positive. Data were obtained for each individual pot and used in statistical analyses

Results

Resistance to rhizomania caused by BNYVV and conferred by the *Rz* allele did not confer resistance to BSBMV in sugar beet in greenhouse pot cultures (Fig. 1). Titers of BNYVV in the rhizomania susceptible variety (7-11 times the healthy mean) were significantly higher than in the resistant variety (<2 times the healthy mean). Slight differences occurred for the titers of

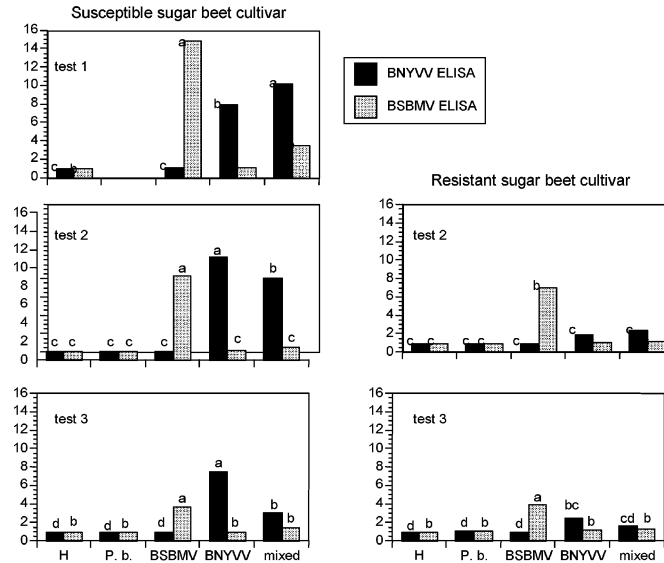

Fig. 1. Absorbance values (A_{405nm}) of test samples divided by the healthy means for susceptible ($r/rz/rz$) and resistant ($R/rz/rz$) sugar beet cultivars. Test 1 consists of four soil treatments and tests 2 and 3 consist of five soil treatments. Bars with letters in common are not significantly different within a test at the $p=0.05$ level.

BSBMV between these varieties when tested as single infections across all six harvest dates. A significant variety \times soil treatment interaction occurred for BNYVV but not for BSBMV.

In test 1, where only the rhizomania-susceptible variety was used, titers of BSBMV were significantly reduced from strongly positive as single infections (almost 15 times the healthy mean), to values only 3.5 times higher than healthy mean values when in mixed infections with BNYVV. In contrast, titers of BNYVV were 7.9 times the healthy mean in single infections and 10.2 times in mixed infections. In tests 2 and 3, titers of BSBMV were significantly reduced in mixed infection soil compared to single infections with either rhizomania-susceptible or resistant varieties (Figure 1). Titrers of BNYVV were positive in the susceptible variety. In test 3, the titers of BNYVV are decreased from 7.5 to 3.1 times the healthy mean between single and mixed infections, but readings were still considered positive in both cases. For the resistant variety, BNYVV ELISA ratios were consistently in the negative range (1.7 to 2.5 times the healthy mean), regardless of whether they existed as single or as mixed infections.

Discussion

Several conclusions were made for the effects of (i) BSBMV, and (ii) mixed infections of BNYVV and BSBMV on sugar beet in greenhouse pot culture. The three tests reported here were conducted sequentially over one year, with different day-lengths and growth potential throughout the year. Nevertheless, the same significant effects were observed.

BSBMV alone replicates to high levels in both resistant and susceptible rhizomania varieties. However, when BSBMV exists as mixed infections with BNYVV, the levels of BSBMV are significantly reduced, even when BNYVV levels are extremely low, as seen in the rhizomania resistant variety. Titrers of BSBMV were significantly reduced in the rhizomania resistant variety as well even with extremely low titers of BNYVV. The titers of BNYVV were also reduced in tests 2 and 3 in the susceptible variety, when in combination with BSBMV, but the titers of BNYVV observed are still considered positive. The significant reduction of BSBMV when in combination with BNYVV could be due to several factors. There may be competition for infection sites by viruliferous *P. betae*. Alternatively, BNYVV-infected zoospores of *P. betae* may be more

aggressive than BSBMV-infected *P. betae*. The viruses may have a competitive advantage once inside the host cells. Another possible explanation for the relationship between these two viruses in mixed infections involves competition for replicative or movement proteins inside the host cells. Regardless of how these two viruses interact in sugar beet, attention should be paid to the negative effect that BSBMV has on beet production. Efforts should be made to determine the extent of the effect of this virus on field production to find resistance to BSBMV.

Acknowledgements

This work has been supported in part by grants from the Beet Sugar Development Foundation, California Beet Growers' Association, Western Sugar Research and Development Foundation.

References

- Abe, H., and Tamada, T. 1986. Association of *Beet necrotic yellow vein virus* with isolates of *Polymyxa betae* Keskin. Ann. Phytopathol. Soc. Japan 52:235-247.
- Barr, D. J. S. 1992. Evolution and kingdoms of organisms from the perspective of a mycologist. Mycologia 84(1):1-11.
- Biancardi, E., Lewellen, R. T., DeBiaggi, M., Erichsen, A. W., and Stevanato, P. 2002. The origin of rhizomania resistance in sugar beet. Euphytica. (in press).
- Canova, A. 1966. Ricerche virologiche nella rizomania della bietola. Annali Accademica Nazionale di Agricoltura 78:37-46.
- Duffus, J. E., and Liu, H.-Y. 1987. First report of rhizomania of sugar beet from Texas. Plant Dis. 71:557.
- Gerik, J. S., Jensen, C. S., and Duffus, J. E. 1987. Soil testing for Rhizomania. The California Sugar Beet 1987:17-28.
- Lee, L., Tedford, E. B., Batten, J. S., Sholthof, K.-B. G., and Rush, C. M. 1999. Nucleotide sequence of *Beet soilborne mosaic virus*. Proc. Fourth Symp. Intl. Working Group on Plant Viruses with Fungal Vectors, pp. 49-52. Monterey, California, October 5-8, 1999.
- Lewellen, R. T. 1995. Performance of near-isolines of sugarbeet with resistance to rhizomania from different sources. Proc. 58th I.I.R.B Congress, pp. 83-91. Beaune, France.
- Lewellen, R. T., and Biancardi, E. 1990. Breeding and performance of rhizomania resistant sugarbeet. Proc. 53rd Winter Congress, I.I.R.B., pp. 69-87. Brussels, Belgium.
- Lewellen, R. T., Skoyen, I. O., and Erichsen, A. W. 1987. Breeding sugarbeet for resistance to rhizomania: evaluation of host-plant reactions and selection for and inheritance of resistance. Proc. 50th Winter Congress, I.I.R.B., pp. 139-156. Brussels, Belgium.
- Obermeier, C. 1998. DNA-gestützte Nachweisverfahren für den Virusübertragenden Bodenpilz *Polymyxa betae* und ihr Einsatz im Rizomania-Resistenztest bei Zuckerrüben. Ph. D. thesis. Technischen Universität Carolo-Wilhelmina zu Braunschweig, Germany.
- Tamada, T., and Baba, T. 1973. *Beet necrotic yellow vein virus* from rhizomania-affected sugar beet in Japan. Annals of the Phytopathological Society of Japan 39:325-332.
- Torrance, L. and Mayo M. A. 1997. Proposed re-classification of furoviruses. Arch. Virol. 142:435-439.
- Tuitert, G., Musters-Van Oorschot, P. M. M., and Hiejbroek, W. 1994. Effect of sugar beet cultivars with different levels of resistance to *Beet necrotic yellow vein virus* on transmission of virus by *Polymyxa betae*. Eur. J. Plant Pathol. 100:201-220.

EXPERIENCES IN THE SEARCH FOR POSSIBLY OCCURRING RECOMBINATIONS BETWEEN A AND B TYPE BEET NECROTIC YELLOW VEIN VIRUS IN TRANSGENIC AND MIXED INFECTED SUGARBEETS.

R. Koenig¹, G. Büttner² and S. Loss¹

¹c/o Biologische Bundesanstalt für Land- und Forstwirtschaft, Messeweg 11, D-38104 Braunschweig, ²Institut für Zuckerrübenforschung, D-37079 Göttingen, Germany.

Summary

In attempts to detect genome recombinations between the closely related A and B types of *Beet necrotic yellow vein virus* (BNYVV) in doubly-infected non-transgenic beets and in transgenic beets which express the coat protein gene of A type BNYVV and are grown in soil containing B type BNYVV, we originally found many potential recombinants in the doubly-infected though not in the transgenic plants. These recombinants, however, proved to be PCR-mediated artifacts. Using modified methods which are able to recognize one recombinant molecule in one million of pure B type molecules we detected BNYVV with a recombined genome neither in transgenic plants in a greenhouse model experiment nor in soil samples from a previous field release experiment.

Introduction

The expression of viral genome sequences has a high potential for establishing virus resistance in transgenic plants. The main argument against the use of this approach under field conditions is that it may foster the development of new viruses due to recombination events that might occur between the transgene-derived viral sequences and the genomes of other viruses or virus strains which infect the transgenic plants (deZoeten, 1992; Rubio et al., 1999). Such recombinations have been observed for DNA as well as for RNA viruses. The recombinations so far described for RNA viruses occurred under high selection pressure. Virus mutants with a weakened pathogenicity due to deletions in their genomes were found to acquire the missing genome parts from transgene-derived RNAs. No data are so far available for economically important crops as to whether in the absence of a selection pressure recombinants between infecting virus- and transgene-derived RNAs may emerge and compete successfully with their well-adapted naturally occurring progenitor viruses. In the present study we have attempted to obtain such information for sugarbeets expressing the coat protein gene of *Beet necrotic yellow vein virus* (BNYVV).

In the *Polymyxa* populations in Europe two major variants of BNYVV have been detected (Kruse et al., 1994; Koenig et al., 1995). The A type is prevalent in Southern and Eastern Europe and surprisingly also in The Netherlands, whereas the B type occurs in Germany, France and adjacent areas. The RNAs of A and B type BNYVV differ in about 3% of their nucleotides. The nucleotide sequences of each of the two types are remarkably stable. Several transgenic sugarbeet lines expressing the coat protein gene of A type BNYVV proved to be highly resistant or almost immune against infections not only by A type but also by B type BNYVV (Büttner and Mangold, 1998). We have examined whether *Polymyxa* populations carrying BNYVV with a recombined genome emerge when A type coat protein-expressing beets are grown in soil containing B type BNYVV. To this aim non-transgenic bait plants were cultivated in soil samples from fields containing B type BNYVV where in previous years A type coat protein gene-expressing sugarbeets had been grown. In addition, a greenhouse model experiment was set up in which measures were taken to increase the likelihood for the appearance and the detection of possibly rarely occurring recombination events. Two transgenic

lines expressing BNYVV A type coat protein were selected which are still fairly susceptible to BNYVV infections. The chances for recombinations to occur are, therefore, much higher than in the commercially interesting lines which are almost immune against the virus. In one of these transgenic lines the resistance was RNA-mediated, in the other one protein-mediated. We also searched for recombinations in non-transgenic plants growing in soil with A and B type BNYVV-carrying *Polymyxa betae*. In order to speed up the possible evolution of recombinants in the *Polymyxa* populations, seven successive crops of were grown in the same soil samples during a period of 28 months. Under natural field conditions with a three year crop rotation this would take more than twenty years. For the sensitive detection of recombinants we originally followed the procedure described in the upper part of Fig. 1. Virus particles from transgenic or mixed infected plants were immuno-captured, their RNA was reversed transcribed (Koenig et al., 1995) and after a 'conservation' PCR with type-independent primers two further 'nested' PCRs were done using the sense primers A1 and A2 and the antisense primers B1 and B2. A1 and A2 are preferentially extended on the A type sequence, because their 3' terminal nucleotide matches this sequence, but mismatches the B type sequence. B1 and B2 are extended preferentially on B type sequences. A1 and A2 bind in regions which are present also in the transgen, whereas B1 and B2 bind in regions which are not present in the transgene. By this means we expected a preferential amplification of A type/B type recombinant sequences.

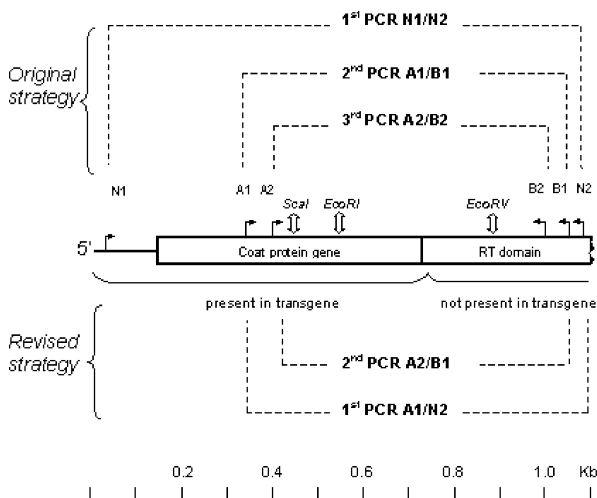

Fig. 1. Schematic representation of the 5' end of BNYVV RNA 2 showing the 5' untranslated region, the coat protein gene and part of the readthrough (RT) domain. The portions of the sequence which are or are not present in the transgene, the location of primers N1, A1, A2, R1, B2, R2, B1 and N2 and of three enzyme cleavage sites which are present only in the A type BNYVV RNA 2 sequence as well as the primer combinations used in PCRs in the original and the revised detection strategies (see text) are also indicated.

Results and Discussion

By means of our original strategy many potential recombinants were found in the doubly-infected though not in the transgenic plants. However, mixed extracts from plants which were singly infected only by A type and only by B type BNYVV, respectively, also yielded recombinants suggesting that these must be PCR-mediated artifacts. Their formation is due to the fact that in each PCR cycle in addition to the full length cDNA copies of the templates also a few incomplete cDNA copies are produced (Fig. 2). The incomplete copy of a BNYVV A type strand may reanneal in the following PCR cycle with a B type strand and its sequence will then be extended as a B type sequence and vice versa. Incomplete cDNA copies may already be formed during reverse transcription. Using an A type-specific primer on one site and a B type-specific primer on the other, as we have done in our original strategy, favours the production of recombination artifacts when both templates are present. The production of abundant amounts

of A type sense strands to which the incomplete B type antisense strands reanneal and of abundant amounts of B type antisense strands to which the incomplete A type sense strands reanneal will lead, upon elongation of the mispaired strands, to the formation of large amounts of recombination artifacts.

We have tried several measures to alleviate the problem of recombination artifacts and

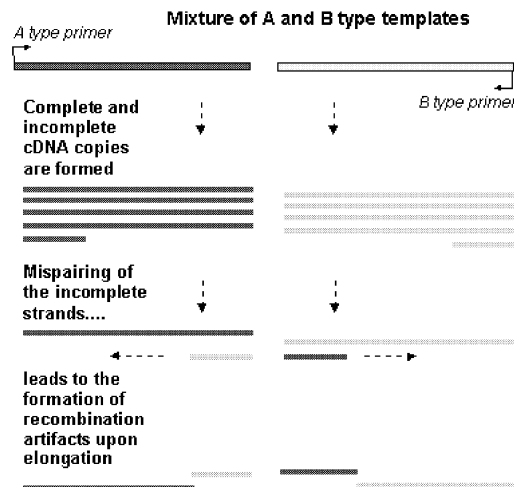

Fig. 2. Formation of PCR-mediated recombination artifacts due to the formation of incomplete cDNA copies which reanneal with the sequence of the other virus type. The phenomenon is favoured by using an A type-specific primer on one and a B type-specific primer on the other end of the sequence to be amplified. The A type primer on the 5'end produces abundant amounts of A type sense strands to which the incomplete B type antisense reanneal. The B type primer on the 3'end produces abundant B type antisense strands to which the incomplete sense strands of the A type reanneal. Recombinants are formed upon elongation. A type strands are highlighted by a dark grey, B types by a light grey.

eventually have adopted a revised strategy (Fig. 1, lower part). The number of PCRs was reduced, because each PCR cycle increases the chances for recombination artifacts to be formed. We omitted the first ('conservation') PCR and used the 'neutral' antisense primer N1 for the 3'end and the A type-specific primer A1 for the 5'end in the first PCR. By this means, in a mixture of A type sequences, A type /B type recombinants and B type sequences, the former two will be amplified preferentially. A second nested PCR with the A type-specific primer A2 on the 5'end and the B type specific primer B1 on the 3'end will selectively amplify the recombinants when B type sequences have not or only to a low extent been amplified in the first PCR. The size of the region to be amplified was reduced (Fig. 1, lower part) and the extension time in the PCR was prolonged from one to three minutes, in order to promote the formation of full length cDNA copies. By means of the revised strategy we were able to detect an artificially produced A type/B type recombinant sequence in an excess of a B type sequence up to a dilution of 10^6 , i.e. 0.0005 ng recombinant plasmid were detected in 500 ng B type plasmid (result not shown).

Despite this high sensitivity we have found no recombinations in any of the experiments which were designed to detect such events due to the cultivation of transgenic plants, i.e. in seven successive crops in the model experiment and in non-transgenic beets which were raised in the soil samples from fields in a B type area in which A type transgenic sugarbeet had been grown previously. We cannot exclude the possibility though that recombinants, especially between the closely related A and B type sequences of BNYVV, might have developed in our experiments in concentrations of less than one to a million, but they have obviously not been able to compete successfully with the naturally occurring progenitor viruses which seem to be well adapted and genetically very stable. As mentioned above, the genome sequences of A type or B type virus sources, respectively, from different parts of Europe are highly conserved (Koenig et al., 1995; Koenig and Lennefors, 2000). If, in the absence of a selection pressure, recombinations between transgene-derived A type sequences and virus-derived B type sequences occur at all, which we could not demonstrate here, the likelihood for such events to take place should decrease with an increasing degree of resistance of the transgenic plants

towards BNYVV infections. Several transgenic lines have proved to be almost immune against BNYVV infections (Büttner and Mangold, 1998, and unpublished observations) and are therefore unlikely to enable recombinations between transgene- and virus-derived BNYVV sequences.

The fact that we readily found recombination artifacts by means of our original strategy (Fig. 1, upper part) indicates that, if recombinants are found, they should be interpreted with great care to make sure that they are not PCR-mediated.

A detailed description of this work will appear elsewhere.

Acknowledgement

We are greatly indebted to the German Bundesministerium für Bildung und Forschung (grant 0312167) for financially supporting this work.

References

- Büttner G, Mangold B (1998) Toleranz, Resistenz, Immunität - Versuch einer Begriffsdefinition für Rizomania. *Zuckerindustrie* 123: 694-701
- de Zoeten GA (1991) Risk assessment: do we let history repeat itself? *Phytopathology* 81: 585-586
- Gibbs RA, Nguyen P, Caskey CT (1989) Detection of single base differences by competitive oligonucleotide priming. *Nucleic Acids Research* 17: 2437-2448
- Koenig R, Lennefors B-L (2000) Molecular analyses of European A, B and P type sources of *Beet necrotic yellow vein virus* and detection of the rare P type in Kazakhstan. *Archives of Virology* 145: 1561-1570
- Koenig R, Lüddecke P, Haeberlé AM (1995) Detection of *Beet necrotic yellow vein virus* strains, variants and mixed infections by examining single-strand conformation polymorphisms of immunocapture RT-PCR products. *Journal of General Virology* 76: 2051-2055
- Kruse M, Koenig R, Hoffmann A, Kaufmann A, Commandeur U, Solovyev AG, Savenkov I, Burgermeister W (1994) RFLP analysis of RT-PCR products reveals the existence of two major strain groups of *Beet necrotic yellow vein virus*. *Journal of General Virology* 75: 1835-1842
- Michaels SD, Amasino RM (1998) A robust method for detecting single-nucleotide changes as polymorphic markers by PCR. *The Plant Journal* 14: 381-385
- Newton CR, Graham A, Heptinstall LE, Powell SJ, Summers C, Kalsheker N, Smith JC, Markham AF (1989) Analysis of any point *Nucleic Acids Research* 17: 2503-2516
- Rubio T, Borja M, Scholthof HB, Jackson AO (1999) Recombination with host transgenes and effects on virus evolution: an overview and opinion *Molecular Plant-Microbe Interactions* 12: 87-92

PARTIAL CHARACTERIZATION OF CUCUMBER NECROSIS VIRUS BINDING SITES ON ZOOSPORES OF THE FUNGAL VECTOR *Olipidium Bornovanus*

D'A. Rochon¹, K. Kakani² and R. Reade¹

¹Agriculture and Agri-Food Canada, Pacific Agri-Food Research Centre, Summerland, B.C., V0H 1Z0 and ²Faculty of Agricultural Sciences, University of British Columbia, Vancouver, B.C., V6T1Z4

Summary

Cucumber necrosis virus (CNV), a member of *Tombusvirus* genus, is naturally transmitted by zoospores of *O.bornovanus*. Previous work from our lab has shown that the coat protein is required for transmission and that the quasi three-fold axis of virus capsid contains determinants involved in virus attachment to zoospores. In the present work we describe the biochemical nature and partial characterization of putative receptors on the zoospore surface. *In vitro* binding studies show that pretreatment of zoospores with trypsin and periodate each decrease CNV binding whereas no reduction in binding was found when zoospores were treated with phospholipase C. These studies suggest the role of zoospore glycoprotein(s) in virus attachment. Virus overlay assays were conducted to see whether any zoospore proteins are involved in virus attachment. CNV bound to several specific-sized proteins, but CNV transmission mutants showed reduced binding or no binding at all. Sugar inhibition studies were done and it was found that several mannose containing sugars inhibited CNV binding to zoospores whereas several other sugars did not. These studies suggest that the putative zoospore receptor may be a mannose containing glycoprotein.

Introduction

Several viruses within the family *Tombusviridae* are transmitted by *Olipidium spp.* Transmission occurs following release of zoospores and virus from different plants into the soil and subsequent adsorption of virus particles onto the zoospore surface (Adams, 1991, Campbell, 1996). Several studies have shown that the transmission process is highly specific. This includes the observation that different *Olipidium spp.* transmit different viruses and that different isolates of *O. bornovanus* vary in transmission efficiency of a given virus (Adams, 1991; Campbell, 1996). Electron microscopy studies have shown that adsorption of virus to the zoospore plasmalemma is specific and reflects the virus/vector associations observed in nature (Temmink et al., 1970). Recently, we have shown that a particular region of the CNV capsid (a cavity near the trimer), is involved in binding zoospores (Kakani et al., 2001). In this study we investigate the possibility that zoospores of *O. bornovanus* contain specific receptors for attachment of CNV and describe results of the preliminary characterization of the biochemical nature of the receptor.

Materials and Methods

O.bornovanus (isolate SS196), kindly provided by R.N. Campbell, was maintained on the roots of cucumber (*C. sativis*, cv. *Poinsette 76*) as described by Campbell et al. (1995). *In vitro* zoospore binding assays were as described previously (Kakani et al., 2001). Treatment of *O.bornovanus* zoospores utilized 5×10^5 *O. bornovanus* zoospores and either 10 mM sodium periodate, 0.1% trypsin or 500 U of phospholipase C. Incubations were for 15 min at room temperature. Treated zoospores were washed prior to the addition of virus (100 ug). Virus overlay assays were essentially as described by Salas-Benito and del Angel (1997) using 2 X

10^6 zoospores per well, 100 μ g of virus as probe and a CNV-specific monoclonal antibody or the respective virus polyclonal antibody for detection. Antigen-antibody complexes were detected using peroxidase-labeled secondary antibody. The microtitre plate binding assay was conducted as follows (McCoy et al., 1983). One hundred μ l of *O. bornovanus* zoospores (2.5×10^4 zoospores) were coated onto 96 well microtitre plates and incubated overnight. Plates were washed with distilled water and blocked at 2 hrs in PBS containing 5% milk powder and 5% BSA. Plates were washed and then incubated with CNV in binding buffer or CNV pre-incubated with sugar solution. Plates were washed as above and the amount of CNV bound determined using a CNV monoclonal antibody followed by detection with goat anti-mouse antibody conjugated to alkaline phosphatase. The relative amounts of bound virus were determined by measuring absorbance at 405 nm. Sugars were tested for ability to inhibit CNV binding to *O. bornovanus* zoospores using several 10-fold and/or 3-fold serial dilutions beginning with 0.2 M sugar. Dilutions of α 3, α 6-mannopentase and mannotriose were as above beginning with 1067 μ M and 538 μ M solutions, respectively.

Results and Discussion

In vitro binding of CNV to zoospores

Previous work has shown that binding of CNV to *O. bornovanus* zoospores is both saturable and specific (Robbins et al., 1999). An analysis of the saturation binding curve in Fig. 1 indicates that approximately 0.018 pmoles of CNV are required to saturate all of the binding sites (B_{max}) present on 4×10^5 zoospores suggesting that 2.7×10^4 binding sites are present on zoospores. This number of binding sites is within the range of virus receptor sites normally found on eukaryotic cells (Wickham et al., 1990). The saturation binding curve in Fig. 1 was also used to calculate the dissociation constant (K_D) for binding of CNV to zoospores. A K_D of 5.7×10^{-9} M was obtained, indicating a very tight association between virus and zoospores. *Sodium periodate, trypsin and phospholipase C treatment of O. bornovanus zoospores*

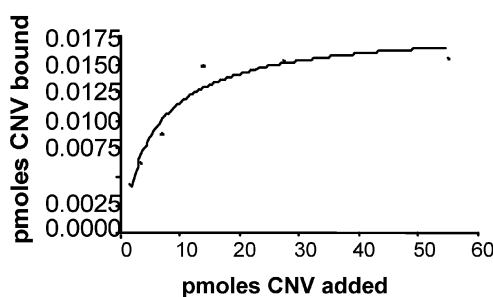

Fig. 1 Zoospore saturation binding curve using CNV virions.

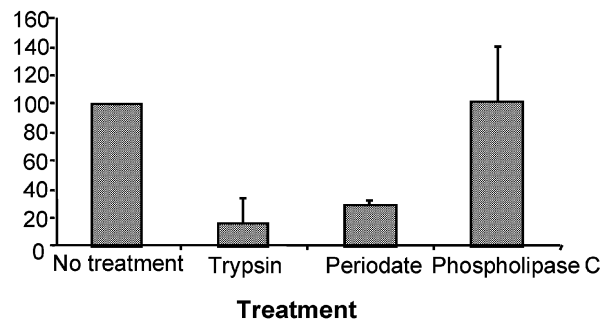

Fig. 2 Effect of trypsin, periodate and phospholipase C treatment on binding of CNV to zoospores. The percentage of binding of CNV to treated versus untreated (defined as 100%) zoospores is shown. Values represent the average of two experiments with three replicates per experiment.

To initially characterize the biochemical nature of the molecule(s) on the surface of *O. bornovanus* zoospores involved in recognizing CNV, 5×10^5 zoospores were treated with either 10 mM sodium periodate, 0.1% trypsin or 500 μ U of phospholipase C. Treated zoospores were washed and subsequently used in an *in vitro* binding assay with CNV virions. Fig. 2 shows that periodate treatment of zoospores decreased CNV binding by 72%, suggesting that carbohydrates are important for CNV binding to zoospores. Trypsin digestion of zoospores reduced virus binding by 84% indicating the protein nature of zoospore binding molecules. No decrease in CNV binding was observed using phospholipase C treated zoospores. Together,

these results suggest that carbohydrate and protein or glycoprotein on the zoospore surface play an important role in CNV binding.

CNV binds to specific-sized proteins in *O. bornovanus* zoospore extracts

Virus overlay assays were conducted to further investigate the possibility that CNV recognizes specific proteins or glycoproteins present on zoospores. Total proteins from 2×10^6 zoospores (Fig. 3A) were subjected to SDS-PAGE, transferred to nitrocellulose membrane, and incubated with 100 μ g of CNV. Bound virus was detected using a monoclonal antibody raised to CNV virions. Fig. 3B shows that CNV bound predominantly to five low molecular weight proteins and several high molecular weight proteins. The binding pattern shown in Fig. 3B was observed repeatedly using different batches of zoospore preparations but slight variations in relative banding intensity were observed. The complexity of the banding pattern suggests that CNV virions may be recognizing a family of proteins or a common residue on multiple proteins such as a specific carbohydrate moiety.

The specificity of the interaction between CNV and zoospore proteins in virus overlay assays was assessed using three previously characterized CNV transmission mutants (LL5, LLK10 and LLK63; Kakani et al., 2001). Fig. 3C shows that LL5 binds with reduced efficiency in virus overlay assays and that little or no binding is observed when LLK10 and LLK63 are used. The

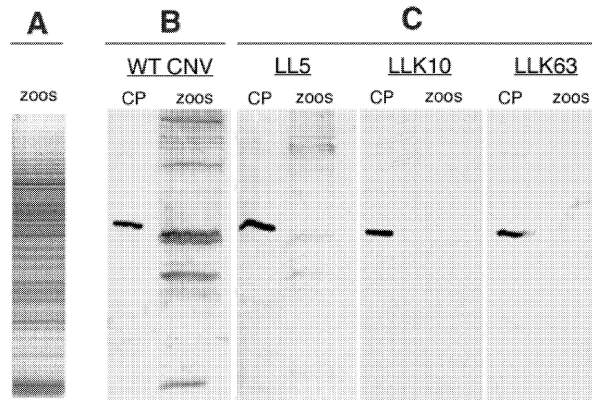

Fig.3 Binding of CNV to zoospore proteins in overlay assays. (A) Coomassie blue-stained total zoospore extracts used in overlay assays. (B) Zoospore proteins that bind to CNV in overlay assays. (C) Binding of three CNV transmission mutants, LL5, LLK10 and LLK63 to zoospore extracts. CP=100 ng CNV CP; zoos = total zoospore extract from 2×10^6 zoospores.

data reinforce the specificity of the interaction between WT CNV and the multiple zoospore species and further suggest that the transmission mutants are deficient in recognizing a common residue present on zoospore proteins such as a specific carbohydrate. CNV binding to *O. bornovanus* zoospores is competitively inhibited by several mannose containing sugars

The possibility that CNV may be recognizing a carbohydrate moiety present on multiple glycoproteins in zoospores was examined using a modified microtitre plate-based enzyme-linked binding assay (McCoy et al., 1983). In this assay, zoospores are bound to microtitre plates, and then incubated with virus in the presence or absence of a specific sugar. The level of bound virus is detected using antibody as in ELISA. Several sugars were tested for inhibitory potential (Table 1). Sugars with an EC50 value less than 10 mM were considered inhibitory. Table 1 shows that mannotriose, α 3, α 6-mannopentaose, methyl α -D-mannopyranoside, mannan, L(-)-fucose and D-mannosamine are each inhibitory.

Table 1. Sugars classified as inhibitors and non-inhibitors in CNV/zoospore binding assays.

Inhibitors ^a	Noninhibitors
Mannotriose (128 μ M)	D(+)-Glucose
α 3, α 6-Mannopentaose (157 μ M)	L(+)-Arabinose
Methyl α -D-mannopyranoside (1.9 mM)	D(+)-Galactose
Mannan (2.0 mM)	N-Acetyl-D-glucosamine
L(-)-Fucose (2.3 mM)	L(-)-Sorbose
D-Mannosamine (2.7 mM)	N-Acetyl-D-mannosamine
	D(+)-Xylose
	D(+)-Mannose
	D(-)-Fructose

^aThe EC50 of each inhibitor is shown in parentheses following the inhibitor.

Taken together, our studies suggest that mannose-containing oligosaccharide(s) play an important role in recognition of zoospores by CNV and, furthermore, that CNV may have lectin-like properties which contribute to its ability to bind its vector. It is known that several animal viruses bind sugars as all or part of the cell recognition process (Wickam et al., 1990) and that, in general, carbohydrates play a significant role in cell recognition and pathogenesis (Sharon and Lis, 1993). Structural studies of the coat protein subunit of tomato bushy stunt (a close relative of CNV) have shown that the shell domain folds into a jellyroll type structure (Chelvanayagam et al., 1992). Interestingly, the lectin, concanavalin A also folds into a jellyroll structure (Chelvanayagam et al., 1992). Indeed, it has been suggested (Argos et al., 1980) that the overall similarity in structural topology between the tombusvirus capsid and ConA may indicate that tombusviruses (as well as other small spherical viruses) have evolved from lectins. The studies described here support the hypothesis that the tombusvirus, CNV, has lectin-like properties that may play a key role in recognition of its vector.

References

- Argos, P., Tsukihara, T. and Rossmann, M.G. (1980) A structural comparison of concanavalin A and *Tomato bushy stunt virus* protein. *J. Mol. Evol.* 15, 169-179.
- Adams, M. J. (1991) Transmission of plant viruses by Fungi. *Ann. Appl. Biol.* 118, 479-492.
- Campbell, R.N. (1996) Fungal transmission of plant viruses. *Annu. Rev. Phytopathol.* 34, 87-108.
- Chelvanayagam, G. Heringa, J and Argos, A. (1992). Anatomy and evolution of proteins displaying the viral jellyroll topology. *J. Mol. Biol.* 228: 220-242.
- Kakani, K., Sgro, J. Y. and Rochon, D. (2001) Identification of *Cucumber necrosis virus* coat protein amino acids affecting fungus transmission and zoospore attachment. *J. Virol.* 75, 5576-5583
- McCoy, J. P., Varani, J. and Goldstein, I. J. (1983) Enzyme-linked lectin assay: use of alkaline phosphatase conjugated *Griffonia simplicifolia* B₄ isolectin for the detection of α -D-galactopyranosyl end groups. *Anal. Biochem.* 130,437-444.
- Robbins, M., Kakani, K. and Rochon, D. (1999) Evidence that fungal zoospores contain specific receptors for transmission of *Cucumber necrosis virus*. Proceedings of the 4th Symposium of the IWGPV. Monterey, CA (eds. J.L. Sherwood and C.M. Rush)
- Salas-Benito, J. S. and Del Angel, R. M. (1997) Identification of two surface proteins from 6/36 cells that bind *Dengue type 4 virus*. *J. Virol.* 71,7246-7252.
- Sharon, N. and Lis, H. (1993). Carbohydrates in cell recognition. *Sci. Am.* 268,82-89.
- Wickham, T.J., Granados, R.R., Wood, H.A., Hammer, D.A. and Shuler, M.L. (1990). General analysis of receptor-mediated viral attachment to cell surfaces. *Biophys. J.* 58, 1501-1515.

OPHIOVIRUSES: HIDING IN THE BACKGROUND, EMERGING FROM THE UNDERGROUND

Robert G. Milne

Istituto di Virologia Vegetale, I-10135 Torino, Italy

Summary

Ophioviruses have combined low concentration and instability *in vitro*, variable and unviru-like EM appearance, and unremarkable reactions in test plants to successfully deceive virologists until quite recently, but evidence now indicates that three diseases are caused by them: citrus psorosis, lettuce big-vein (BV) and tulip mild mottle mosaic. Ophioviruses are associated with three other diseases, ranunculus white mottle, freesia leaf necrosis and *Lettuce ring necrosis*. Classical work on *Olpidium brassicae* (OB) transmission of BV through the soil has recently been confirmed except in one important detail: two viruses, the ophiovirus *Mirafiori lettuce virus* (MiLV) and the varicosavirus *Lettuce big-vein virus* (LBVV) are there for the price of one. Both are transmitted in the same manner, but present data indicate that only MiLV causes BV, and LBVV causes no symptom in lettuce. *Tulip mild mottle mosaic virus* from Japan, serologically related to MiLV, is also transmitted by OB, as are the agents of *Lettuce ring necrosis* and freesia leaf necrosis. Other emerging properties of the genus *Ophiovirus* are: genome of at least 3, probably 4 ssRNAs, all negative-stranded, of about 8, 1.7, 1.5 and 1.4 kb; finely filamentous particles 3 nm in diameter and of different contour lengths. Homologies in the RNA polymerase gene (at amino-acid level) place ophioviruses close to other negative-stranded but monopartite viruses in the Order Mononegavirales.

Introduction

It is only now becoming clear that viruses in the genus *Ophiovirus* can be important pathogens, and that at least some of them are soil-transmitted by the fungus *Olpidium brassicae*. Developments in this new and fast-moving field suggested that a short review of the ophioviruses might be appropriate at the present meeting, but in writing the text I have also included some of the latest developments that came out at the Joint Conference of the International Working Groups on Legume and Vegetable Viruses, Bonn, August 2002. Incidentally, and in the context of *Quis custodiet ipsos custodes?* (Who is to guard the guardians themselves?) (Juvenal, AD 60- ~130), it is an interesting piece of pathology that some of the leading plant virologists were hoodwinked for so long as to the nature of an important world-wide 'text-book' disease such as lettuce big-vein.

Taxonomy and nomenclature

At present, the genus *Ophiovirus*, not assigned to any family, officially contains three species, *Citrus psorosis virus* (CPsV), *Ranunculus white mottle virus* (RWMV) and *Tulip mild mottle mosaic virus* (TMMMV) (Milne *et al.*, 2000). Candidate species are an unnamed ophiovirus from freesia associated with freesia leaf necrosis (Bouwen, 1994; V. Lisa, R. G. Milne and A. Vaira, unpublished), Mirafiori lettuce virus (MiLV) (Roggero *et al.*, 2000; Lot *et al.*, 2002; van der Wilk *et al.*, 2002), and a virus associated with *Lettuce ring necrosis* (Torok and Vetten, 2002).

There appears to be one coat protein (CP) of about 48 kDa, and 3 genomic ssRNAs have been described, but it now seems that there are 4 (van der Wilk *et al.*, 2002; Torok and Vetten, 2002), with the polymerase encoded by RNA1 and the CP by RNA3. All functional open reading frames detected are in the negative strand.

The particles of ophioviruses resemble those of tenuiviruses (a genus of cereal and grass viruses that multiply in their planthopper vectors) and also resemble the nucleocapsids of members of the *Bunyaviridae* such as *Tomato spotted wilt virus*. However, data now emerging on amino acid sequence domains in the polymerases of ophioviruses indicate no similarities with the above viruses, but significant homologies with viruses in the Order *Mononegavirales*, comprising viruses such as the rhabdoviruses, with monopartite entirely negative-stranded genomes. These data (all in agreement) come from CPsV (group of M. L. Garcia, unpublished) MiLV (van der Wilk *et al.*, 2002) and RWMV (Vaira *et al.*, 2002). Moreover, new sequence data on the polymerase of the varicosavirus *Lettuce big-vein virus* (LBVV; Sasaya *et al.*, 2002) also place it taxonomically close to the rhabdoviruses. If all these early results are confirmed, a new taxon will have to be invented for viruses with similarities to the *Mononegavirales*, but with divided genomes. They might form a new Family that could be named the *Ophioviridae* within the Order *Oligonegavirales*.

Hiding in the background

Experience with the nucleocapsids of tospoviruses might have taught electron microscopists how to see ophiovirus particles, but almost nobody has this experience, and to my knowledge there is no widely published micrograph (but see Kikkert, 1999, p. 12). Likewise, experience with the particles of tenuiviruses might have helped, but those working on cereals generally do not also work on citrus, ornamentals or vegetables. And the only tenuivirus known in Europe, *European wheat striate mosaic virus*, is something of a rarity, worked on hardly at all. In any case, the particles of ophioviruses remained unrecognised, almost certainly passing across the retinas of virologists without firing any neurones in the optical cortex. If noticed, they were probably written off as host contaminants, and their very variable appearance certainly did not help them to be considered as virions, especially as other viruses with more easily recognised particles were often also present, and a seemingly sufficient cause of the disease. It is not helpful that ophiovirus particles have never been seen in thin sections, even when specifically looked for, as with CPsV, RWMV and MiLV; this is probably because the thin randomly oriented filaments, of low contrast and not highly concentrated, make a poor target.

And it turns out that The Lord does play jokes: He/She placed before us a nice disease (lettuce big-vein) with an intriguing mode of transmission through the soil via *Olpidium*, and an obvious virus transmitted in this way, plus a second much less obvious virus transmitted in the identical manner. The two (unrelated) viruses have coat proteins of essentially the same size, 48 kDa. Who among mortals was to suppose that the first virus was innocent and the second (undetected) virus the guilty party, especially as Koch's postulates, as applicable to viruses, proved difficult to perform? Purified and infectious preparations could not consistently be obtained (Vetten *et al.*, 1987; Huijberts *et al.*, 1990). Even the symptoms produced by the two viruses upon mechanical inoculation of test plants are very similar and were not distinguished. It is curious that another varicosa-ophio joke may be being played in the case of freesia leaf necrosis disease.

Luckily a situation arose, with citrus psorosis, where only one virus was present, and after partial purification, the contents of the tube was consistently infectious on test plants. Something had to be in there, and thus the first ophiovirus particles were detected (Derrick *et al.*, 1988; Garcia *et al.*, 1994; Milne *et al.*, 1996).

Emerging from the underground

Freesia leaf necrosis is a disease transmitted by *Olpidium* (Bouwen, 1994) and ascribed to a varicosavirus, *Freesia leaf necrosis virus* (Brunt *et al.*, 1996). At a symposium in Wageningen in 1998 we saw electron micrographs (I. Bouwen, unpublished) of partially purified preparations of this 'virus', apparently containing varicosavirus and ophiovirus particles. Subsequently we confirmed the presence of an ophiovirus associated with freesia leaf necrosis in Liguria, Italy (A. Costantini, V. Lisa, R. G. Milne and A. M. Vaira, unpublished).

Morikawa *et al.* (1995) had already published that the soil-transmitted tulip mild mottle mosaic disease was associated with an ophiovirus, and later reported (unpublished) that the vector was *Olpidium brassicae*. These clues led us to detect (Roggero *et al.*, 2000) the presence of an ophiovirus in big-vein affected lettuces; at least sometimes, this virus was capable of causing big-vein. We were then fortunate to persuade Bob Campbell and Herve Lot to do the real work of showing that MiLV and not LBVV was the agent causing big-vein, although both viruses were transmitted in the same manner (Lot *et al.*, 2002). This was possible because we could recognise the distinct particle morphologies and had obtained specific antisera. This work awaits confirmation, but the interesting news (Torok and Vetten, 2002) is that the *Olpidium*-transmitted *Lettuce ring necrosis* disease (Bos and Huijberts, 1996; Campbell and Lot, 1996) is associated with an ophiovirus, different from MiLV.

Thus we have MiLV, TMMMV, and ophioviruses associated with freesia leaf necrosis and with *Lettuce ring necrosis*, all *Olpidium*-transmitted. Citrus psorosis, caused by CPsV, is found worldwide where citrus is grown, and there are reports, although not confirmed, of limited natural field spread. The virus has probably been vegetatively propagated for centuries, and it could have lost any putative original capacity to be transmitted by *Olpidium*.

Discussion

The year 2002 has witnessed definitive addition of the ophioviruses to the interesting category of plant viruses with fungal vectors, and has resolved in dramatic fashion the very curious question of exactly what was transmitted from lettuce to lettuce, causing big-vein. These viruses are no longer hiding, but definitely emerging.

Acknowledgements

Thanks to Maria Laura Garcia, University of La Plata, Argentina, and Vittoria Lisa and Anna Maria Vaira, Plant Virus Institute, Turin, Italy, for sharing their unpublished data.

References

- Bos, L., and Huijberts, N. (1996). *Lettuce ring necrosis*, caused by a chytrid-borne agent distinct from lettuce big-vein 'virus'. *Eur. J. Pl. Pathol.* 102, 867-873.
- Bouwen, I. (1994). Freesia leaf necrosis: Some of its mysteries revealed. *Acta Hort.* 377, 311-318.
- Brunt, A. A., Crabtree, K., Dallwitz, M. J., Gibbs, A.J., and Watson, L. (1996). *Viruses of Plants. Descriptions and Lists from the VIDE Database.* CAB International, Wallingford, Oxford.
- Campbell, R. N., and Lot, H. (1996). *Lettuce ring necrosis*, a virus-like disease of lettuce: evidence of transmission by *Olpidium brassicae*. *Plant Disease* 80, 611-615.
- Derrick, K. S., Brlansky, R. H., Da Graca, J. V., Lee, R. F., Timmer, L. W., and Nguyen, T. K. (1988). Partial characterization of a virus associated with *Citrus ringspot*. *Phytopathology* 78, 1298-1301.

- Garcia, M. L., Dal Bo, E., Grau, O., and Milne, R. G. (1994). The closely related *Citrus ringspot* and *Citrus psorosis viruses* have particles of novel filamentous morphology. *J. Gen. Virol.* 75, 3585-3590.
- Huijberts, N., Blystad, D. R., and Bos, L. (1990). *Lettuce big-vein virus*: Mechanical transmission and relationships to *Tobacco stunt virus*. *Ann. Appl. Biol.* 116, 463-475.
- Juvenal (AD 60- ~130). Satires iii, English translation by Lewis Evans, p. 347 (Oxford Dictionary of Quotations 1954, p. 283).
- Kikkert, M. (1999). Role of the envelope glycoproteins in the infection cycle of *Tomato spotted wilt virus*. Doctoral thesis, Agricultural University Wageningen, The Netherlands.
- Lot, H., Campbell, R. N., Souche, S., Milne, R. G., and Roggero, P. (2002). Transmission by *Olpidium brassicae* of *Mirafiori lettuce virus* and *Lettuce big-vein virus*, and their roles in *Lettuce big-vein* etiology. *Phytopathology* 92, 288-293.
- Milne, R. G., Djelouah, K., Garcia, M. L., Dal Bo, E., and Grau, O. (1996). Structure of *Citrus ringspot-psorosis*-associated virus particles: Implications for diagnosis and taxonomy. In "Proceedings of the Thirteenth Conference, International Organization of Citrus Virologists", (J. V. da Graca, P. Moreno and Y. Yokomi, Eds.), pp. 189-197, IOCV, Riverside, CA.
- Milne, R. G., Garcia, M. L., and Grau, O. (2000). Genus *Ophiovirus*. In *Virus Taxonomy*. Seventh Report of the International Committee on Taxonomy of Viruses (M. H. V. van Regenmortel *et al.*, Eds.) pp. 627-631. Academic Press, New York.
- Morikawa, T., Nomura, Y., Yamamoto, T., and Natsuaki, T. (1995). Partial characterization of virus-like particles associated with *Tulip mild mottle mosaic*. *Ann. Phytopathol. Soc. Japan* 61, 578-581.
- Roggero, P., Ciuffo, M., Vaira, A. M., Accotto, G. P., Masenga, V., and Milne, R. G. (2000). An *Ophiovirus* isolated from lettuce with big-vein symptoms. *Arch. Virol.* 145, 2629-2642.
- Sasaya, T., Ishikawa, K., and Koganezawa, H. (2002). Analysis of RNA1 of *Lettuce big-vein virus*, genus *Varicosavirus*, reveals its relation to *Rhabdoviruses*. Abstracts, "Fifth Symposium, International Working Group of Plant Viruses with Fungal Vectors", Zurich, July 2002, p. 4.
- Torok, V. A., and Vetten, H. J. (2002). Characterisation of an ophiovirus associated with *Lettuce ring necrosis*. In Abstracts, "First Joint Conference, International Working Groups on Legume and Vegetable Viruses" Bonn, August 2002 (D.-E. Lesemann and H. J. Vetten, Eds.), p. 4.
- Vaira, A. M., Costantini, A., and Accotto, G. P. (2002). A partial sequence of the putative RNA polymerase gene of *Ranunculus white mottle ophiovirus*. Abstracts, "IUBMB Symposium on Genome Replication of RNA Viruses" Helsinki, Finland, June 2002, p. 53.
- van der Wilk, F., Dullemans, A. M., Verbeek, M., van den Heuvel, J. F. J. M., and van der Vlugt, R. A. A. (2002). Nucleotide sequence and genomic organization of an ophiovirus associated with *Lettuce big vein* disease. In Abstracts, "First Joint Conference, International Working Groups on Legume and Vegetable Viruses" Bonn, August 2002 (D.-E. Lesemann and H. J. Vetten, Eds.), p. 2.
- Vetten, H. J., Lesemann, D. E., and Dalchow, J. (1987). Electron microscopical and serological detection of virus-like particles associated with *Lettuce big vein* disease. *J. Phytopathol.* 120, 53-59.

CHARACTERISATION OF RESISTANCE TO BARLEY MILD MOSAIC VIRUS

G.R.D. McGrann and M.J. Adams

Plant Pathogens Interactions Division, IACR-Rothamsted, Harpenden, Herts, AL5 2JQ, UK

Summary

Many genes have been identified that confer resistance to components of soilborne barley mosaic disease but little is known concerning the mechanisms of resistance. Several barley genotypes and breeding lines carrying resistance genes have been tested by mechanical and fungal inoculation for their resistance reaction to *Barley mild mosaic virus* (BaMMV). The genes rym 1, rYm 2, rym 5 and rym 11 all confer immunity to BaMMV similar to that of rym 4. BaMMV could be detected in the tissues of lines carrying rym 3, rym 6, rym 7, rym 8, rym 9 and rym 10 and was transmitted to susceptible test plants by zoospores propagated on plants carrying these genes. Studies demonstrated that rym 7 and rym 8 are temperature sensitive, conferring BaMMV resistance at 12°C but not 20°C following mechanical inoculation of leaves.

Introduction

Barley mild mosaic virus (BaMMV) is one of the two viruses that cause soilborne barley mosaic disease, a serious threat to European and East Asian winter barley production. Because the disease is soilborne, control is only possible by using resistant varieties. Resistance to the European strains of BaMMV and *Barley yellow mosaic virus* (BaYMV) has been based on a single recessive gene, rym 4, which conferred immunity to the disease. However in the late 1980s a strain of BaYMV, (BaYMV-2), able to infect rym 4 varieties was described, forcing plant breeders to look for novel sources of resistance (Huth 1989; Huth and Adams 1990). Extensive screening of exotic barley germplasms has identified 13 genes that confer resistance to all or part of the disease complex but little is known regarding the resistance mechanism of these genes (Ordon and Friedt 1993). In this report we describe the resistance reaction conferred by the resistance genes rym 1, rYm 2, rym 3, rym 4, rym 5, rym 6, rym 7, rym 8, rym 9, rym 10 and rym 11 to BaMMV and the plant tissues in which BaMMV can be detected after inoculation.

Materials and Methods

Cultivars and breeding lines used in this report and the resistance genes they carry were: F3 501 230 60 (rym 1), Mokusekko 3 (rym 1 + rym 5), Mihori Hadaka 3 (rYm 2), Ea 52 (rym 3), Jewel (rym 4), Resistant Ym No. 1 (rym 5), Miho Golden (rym 6), Hhorr 3365 (rym 7), 10247 (rym 8), Bulgarian 347 (rym 9), Hiberna (rym 10) and Russia 57 (rym 11). The cultivars Regina and Fanfare, carrying no known resistance gene, were used as susceptible controls.

Plants were mechanically inoculated with BaMMV using an air brush (Adams, Swaby, and Macfarlane 1986), grown at 12°C or 20°C and scored for virus symptoms 42 and 28 days after inoculation (dai) respectively. Seedling roots were inoculated with viruliferous resting spores of Streatley, Bedfordshire, UK and Gottingen, Germany isolates of *Polymyxa graminis* Led.. After growing in sand culture for 28 days, zoospores were collected, counted and inoculated onto the roots of 2-3 day old seedlings of susceptible cultivars, which were then grown at 20°C and cut back 28 dai to stimulate systemic virus movement and symptom production. Zoospores propagated on a susceptible variety were used to inoculate lines carrying resistance genes as described.

Root and leaf tissues from plants inoculated with resting spores were tested for the presence of BaMMV by ELISA and RT-PCR. Antiserum prepared to a UK isolate of BaMMV was used in

an indirect F(ab')₂ ELISA as described by Adams (1991). A positive result was recorded when a sample had an absorbance (A_{405nm}) in excess of twice that of the relevant healthy control. Total RNA was extracted from 0.2g plant tissue and used in RT-PCR reactions using primers designed to regions of homology in published sequences of RNA-1 of UK, German and Japanese isolates of BaMMV. The forward primer M3 (5'-ACAGAGCACGAGGAA-3') and reverse primer M4 (5'-GCATGAGAGATCTACCGG-3') amplify an 899bp DNA fragment from the 3' end of RNA-1 including the capsid protein region (Schenk *et al.* 1995). The PCR products were analysed by electrophoresis in 1.4% agarose gels.

Results

Following mechanical inoculation and growth at either 12°C or 20°C, plants containing rym 1, rym 4, rym 9 and rym 11 remained free of symptoms (apart from a few plants that were considered false positives caused by seed contamination) whereas those with rym 3 and rym 6 showed typical BaMMV symptoms at both temperatures. Plants with rym 7 and rym 8 developed symptoms at 20°C but not at 12°C. Lines carrying rym 5 and rym 10 were only tested at 20°C with rym 5 plants free of virus symptoms and rym 10 plants susceptible (Table 1).

Table 1. BaMMV symptom development on plants containing different resistance genes after different types of inoculation, and viral transmission from such plants to test seedlings.

Gene	Mechanical inoculation ^a		Resting spore inoculation ^b		Zoospore inoculation ^c	Zoospore count ^d	BaMMV Transmission ^e
	12°C	20°C	L	R			
rym 1	0.0	0.0	0.0	0.0	0.0	6.06	0.0
rym 1 + rym 5	0.0	0.0	0.0	0.0	0.0	6.15	0.0
rYm 2	nt	nt	0.0	0.0	nt	6.25	0.0
rym 3	51.6	65.0	66.6	100.0	47.5	6.64	31.7
rym 4	2.5	0.2	0.0	0.0	0.0	6.29	4.8
rym 5	nt	1.9	0.0	0.0	0.0	6.43	0.0
rym 6	33.3	50.7	0.0	80.0	0.0	6.42	51.9
rym 7	0.0	68.7	100.0	100.0	50.0	6.38	47.6
rym 8	0.0	13.0	8.3	100.0	0.0	6.48	58.8
rym 9	0.0	0.0	0.0	70.0	0.0	6.37	63.3
rym 10	nt	74.8	0.0	50.0	42.9	6.31	63.0
rym 11	0.0	0.0	0.0	0.0	0.0	6.45	0.0
None	61.3	63.1	41.6	100.0	46.3	6.52	60.6

^a Percentage plants with symptoms 42 dai at 12°C and 28 dai at 20°C

^b Percentage plants positive in ELISA 70 dai, L = leaf tissue, R= root tissue

^c Percentage plants with symptoms 84 dai (119 dai for rym 3)

^d Log₁₀ transformation of spores/ml

^e Percentage test plants with symptoms 112 dai

nt Not tested

The results from the resting spore inoculations were similar with either the German or UK isolates of viruliferous *Polymyxa graminis* and they have therefore been combined. BaMMV could not be detected in either leaf or root tissue of plants with genes rym 1, rYm 2, rym 4, rym 5 or rym 11 but was detected in both tissues of susceptible controls and plants with genes rym 3, rym 7 and rym 8. In plants with rym 6, rym 9 and rym 10, BaMMV could only be detected in

root tissue. The presence of BaMMV in root tissues was confirmed by RT-PCR (Fig. 1). Following inoculation with a viruliferous zoospore suspension (2.92×10^6 spore/ml), symptoms were seen on the leaves of plants with rym 3 and rym 7 (as with resting spore inoculation). Symptoms were also seen in plants with rym 10 but not in the leaves of plants with rym 8 (unlike resting spore inoculation). However symptoms only became apparent after plants had been cut back 1-2cm from the soil (Table 1).

Fig. 1 Detection of BaMMV in roots of lines carrying resistance genes 70 dai with viruliferous *Polymyxa graminis* resting spores Mk 1Kb ladder (Promega), 1) rym 1; 2) rym 1 + rym 5; 3) rYm 2; 4) rym 3; 5) rym 4; 6) rym 5; 7) rym 6; 8) rym 7; 9) rym 8; 10) rym 9; 11) rym 10; 12) rym 11; 13) no resistance gene

Mk 1 2 3 4 5 6 7 8 9 10 11 12 13 Mk

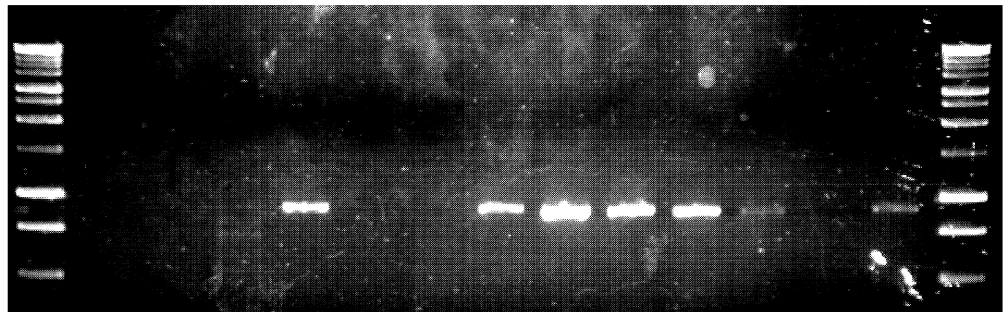

BaMMV transmission from the resistant lines was investigated by collecting zoospores 28 dai, inoculating them on to a susceptible variety and scoring the virus symptoms that developed. BaMMV was transmitted from plants with rym 3, rym 6, rym 7, rym 8, rym 9 or rym 10 but not from those with rym 1, rYm 2, rym 5 or rym11. A few plants became infected when inoculated with zoospores from the rym 4 cultivar. Zoospore production did not differ significantly between genotypes (Table 1).

Discussion

This study indicates that the resistance genes studied operate by more than one mechanism. The immunity demonstrated by rym 4 cultivars was also observed in F3 501 230 60 (rym 1), Mokusekko 3 (rym 1 + rym 5), Mihori Hadaka 3 (rYm 2), Resistant Ym No. 1 (rym 5) and Russia 57 (rym 11). Resistance(s) conferred by rym 7 (Graner et al. 1999) and rym 8 (Bauer et al. 1997) have been shown previously to operate as partial resistance by delaying symptoms or reducing virus replication. Adams (1994) also described partial resistance in the cultivar Sprite where zoospores contained virus. Immune cultivars carrying the rym 4 gene produce non-viruliferous zoospores, although it has been shown that after the initial passage through an immune variety very low levels of transmission are possible (Adams, Jones, and Swaby 1987) as was observed in these experiments. Because BaMMV could be detected in the roots of Bulgarian 347 but never in the leaves, it seems likely that rym 9 operates only in the leaves. Such plants would appear resistant by mechanical inoculation but could contain virus in the roots maintaining the amount of inoculum if planted in infested soil.

The difference in BaMMV symptom production in plants with rym 8 or rym 10 following fungal inoculation may be related to physiological factors. BaMMV could not be detected in plants with

rym 10 after resting spore inoculation but BaMMV symptoms were observed after inoculation with zoospores. Plants with rym 10 inoculated with zoospores were cut back to stimulate systemic virus movement, leading to symptom production but those inoculated with resting spores were not cut. Variation in symptom production due to differing agronomic traits in resistant genotypes could be greatly reduced by using near isogenic lines carrying the different resistance genes, although the production of such lines is difficult and time consuming. It is clear that further studies are required to gain a fuller understanding of the mechanisms of resistance to BaMMV in relation to temperature sensitivity, gene expression, virus movement and virus multiplication.

We thank Dr. Frank Ordon, Institute of Agronomy and Plant Breeding, Justus-Liebig University, Germany, and Dr Taeko Konishi, Faculty of Agriculture, Kyushu University, Japan for their kind gifts of barley seed carrying resistance genes used in this work. Graham McGrann is a student registered at the University of Nottingham, UK. This work was partly funded by CPB-Twyford Ltd, UK. IACR receives support from the Biotechnology and Biological Sciences Research Council of the United Kingdom.

References

- Adams, M. J., A. G. Swaby, and I. Macfarlane. 1986. The susceptibility of barley cultivars to *Barley yellow mosaic virus* (BaYMV) and its fungal vector, *Polymyxa graminis*. *Annals of Applied Biology* 109:561-72.
- Adams, M. J., P. Jones, and A. G. Swaby. 1987. The effect of cultivar used as host for *Polymyxa graminis* on the multiplication and transmission of *Barley yellow mosaic virus* (BaYMV). *Annals of Applied Biology* 110:321-327.
- Bauer, E., J. Weyen, A. Schiemann, A. Graner, and F. Ordon. 1997. Molecular mapping of novel resistance genes against *Barley mild mosaic virus* (BaMMV). *Theoretical and Applied Genetics* 95:1263-1269.
- Graner, A., S. Streng, A. Kellermann, G. Proeseler, A. Schiemann, H. Peterka, and F. Ordon. 1999. Molecular mapping of genes conferring resistance to soilborne viruses in barley - an approach to promote understanding of host-pathogen interactions. *Zeitschrift Fur Pflanzenkrankheiten Und Pflanzenschutz-Journal of Plant Diseases and Protection* 106:405-410.
- Huth, W. 1989. Ein weiterer Stamm des *Barley yellow mosaic virus* (BaYMV) gefunden. *Nachrichtenblatt des Deutschen Pflanzenschutzdienstes (Stuttgart)* 41:6-7.
- Huth, W., and M. J. Adams. 1990. *Barley yellow mosaic virus* (BaYMV) and BaYMV-M: two different viruses. *Intervirology* 31:38-42.
- Ordon, F., and W. Friedt. 1993. Mode of Inheritance and Genetic Diversity of Bammv Resistance of Exotic Barley Germplasms Carrying Genes Different from Ym4. *Theoretical and Applied Genetics* 86:229-233.
- Schenk, P. M., J. F. Antoniw, MdeF. Batista, V. Jacobi, M. J. Adams, and H.-H. Steinbiss. 1995. Movement of barley mild mosaic and *Barley yellow mosaic viruses* in leaves and roots. *Annals of Applied Biology* 126:291-305.

ISOLATION AND CHARACTERIZATION OF GENES INDUCED DURING NON-HOST RESISTANCE TO *POLYMYXA* SPP

C.S. Kingsnorth, E.S. Mutasa-Göttgens and M.J.C. Asher

Broom's Barn, Higham, Bury St Edmunds, Suffolk, IP28 6NP, U.K.

Summary

Polymyxa spp. are important vectors for the transmission of a number of plant viruses including *Beet necrotic yellow vein virus*, *Barley mild mosaic virus* and *Barley yellow mosaic virus*. The two species *P. betae* and *P. graminis* differ in their host ranges, being able to infect members of the Chenopodiaceae and Gramineae respectively. We have been investigating the molecular events that occur when susceptible host, resistant and non-host plants are challenged with both a compatible and incompatible *Polymyxa* sp. Using the representational difference analysis technique, libraries have been generated that are enriched for cDNA sequences derived from genes whose transcription is altered as a result of infection. Initial analysis of these libraries has revealed a number of cDNAs with similarities to genes previously implicated in plant disease response. We are currently screening the libraries to identify genes that are induced only during a non-host infection and also those that are up-regulated during infection of a susceptible host, but that have no homology to sequences in the DNA databases.

Introduction

Viruses vectored by the plasmodiophorid species *Polymyxa betae* and *P. graminis* cause many economically damaging plant diseases. Commercial varieties with resistance to the viruses are available and are grown widely throughout continental Europe and the USA (Richard-Molard and Cariolle, 2001). The widespread use of these cultivars, combined with the fact that they are based on monogenic partial resistance, means that erosion of the resistance by novel strains of the virus is a real possibility. This could be overcome by combining resistance to the virus and vector in the same plant. To generate plants that resist *Polymyxa* infection, we need to investigate further the basis of the naturally occurring resistance to *Polymyxa* found in wild *Beta* species (Fujisawa and Sugimoto, 1979). For example, when *B. patellaris* is challenged with *P. betae*, the parasite is able to adhere to and penetrate the root, but is unable to complete the infection (Barr *et al.*, 1995). This failed infection attempt is sufficient to prevent or greatly reduce transmission of *Beet necrotic yellow vein virus* (Paul *et al.*, 1992). There is also another form of resistance to this parasite. The two species, of *Polymyxa* have limited host ranges; *P. betae* is only able to infect the Chenopodiaceae, whereas *P. graminis* can only infect the Gramineae. This is termed incompatible or non-host resistance, and is where an entire plant species or family is resistant to a specific parasite or pathogen (Heath, 2000). This mechanism of resistance may be controlled at the genetic level, with plants being able to stop infection of non-host pathogens through the activation of certain genes or pathways.

We have chosen to look at the basis of this non-host resistance to *Polymyxa* at the molecular level. Using representational difference analysis (RDA) the identification of genes whose steady state transcription is altered during infection was carried out. Libraries have been generated of expressed sequence tags (ESTs) enriched for genes that are differentially expressed in susceptible, resistant and non-host interactions. The characterization of these ESTs will allow us to determine some of the processes that are occurring in the challenged plants. By comparing the three libraries we can also identify genes whose transcript levels alter only in response to a specific type of infection e.g. non-host.

Materials and Methods

Plant growth conditions and harvesting

The sugar beet, *Beta vulgaris* cv. Saxon (Hilleshog) and the wild *Beta* species, *B. patellaris*, were used throughout this study. *P. graminis* infected plants were supplied by Dr Mike Adams (Rothamsted Research). Zoospores were released from infected plants into a 0.5% (w/v) solution of bovine serum albumin (BSA) at room temperature for one hour. Once released the zoospores were immobilized, their concentration measured in a haemocytometer and adjusted to 10^6 zoospores per milliliter. Ten day old seedlings were challenged by immersing the roots in the zoospore suspension; control uninfected plants were generated by immersion in 0.5% (w/v) BSA. Ten plants from both experimental and control samples were removed at hourly intervals, the roots severed then immediately frozen in liquid nitrogen. The plant roots from each set were pooled to generate separate healthy and infected root tissue samples covering a time period of 7 hours post-challenge. The three types of infection used in this study were: (1) susceptible interaction - *P. betae* challenging *B. vulgaris*; (2) resistant interaction - *P. betae* challenging *B. patellaris* and (3) non-host interaction - *P. graminis* challenging *B. vulgaris*.

RNA isolation and RDA analysis

Frozen root material was ground to a fine powder in liquid nitrogen. Total and poly(A)⁺ RNA was then extracted using the RNeasy Plant Mini Kit and Oligotex mRNA kit respectively (Qiagen GmbH, Hilden, Germany). The quantity and purity of RNA was determined by absorbance at 260 and 280 nm. RNA integrity was confirmed by agarose gel electrophoresis. cDNA production and RDA analysis was done using the method of Chang et al., 1998), summarized in Fig. 1.

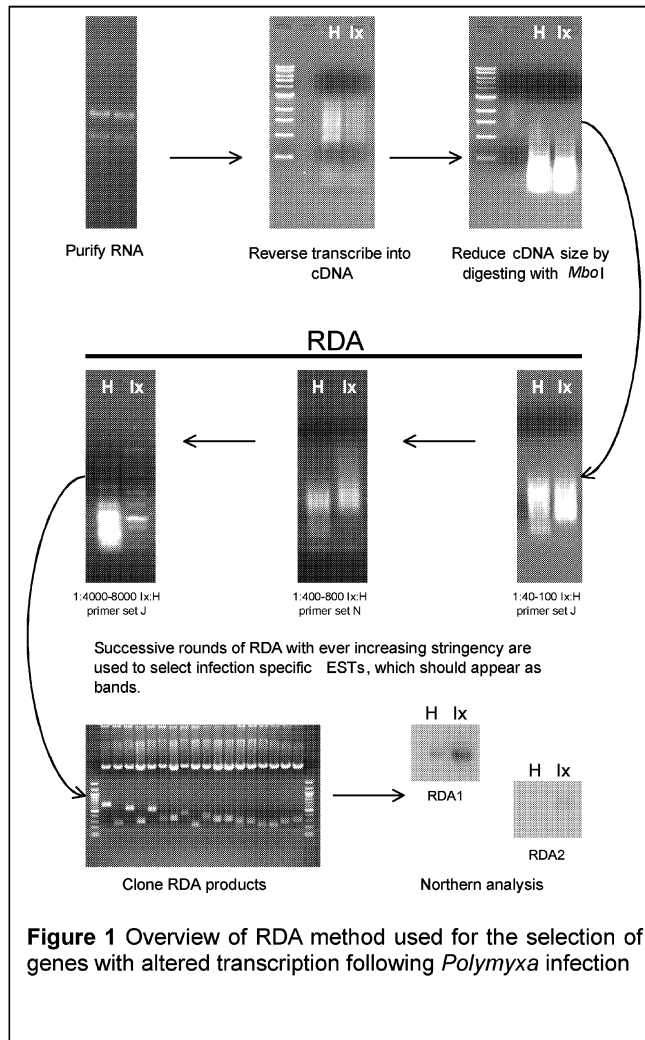

DNA manipulation

RDA products were cloned using the PCR-Script™ Amp cloning system (Stratagene). Resultant plasmids were used to construct an assayed library (96 well format) in microtitre

dishes containing Media 97 (Eastwood et al., 2001). For long term storage the plates were stored at -80°C. Plasmid preparation for sequencing was carried out using standard conditions (Sambrook et al., 1989) and further purified using the QIAquick nucleotide removal system (Qiagen). DNA sequencing was carried out using commercial facilities (DBS Genomic, Durham, UK).

Results and Discussion

The RDA technique is a powerful tool for the identification of differentially expressed genes. The RDA process was optimized for our conditions and successfully used to select for differentially expressed ESTs from susceptible, resistant and non-host interactions. Preliminary Northern analysis revealed that the library did contain differentially expressed sequences. Initial DNA sequence analysis has demonstrated that the cDNAs isolated have homology with genes that have been previously implicated in plant pathogen interactions (Table 1).

Table 1: *In silico* predicted function of randomly isolated ESTs from RDA libraries. Where an EST has been previously implicated in plant disease response an appropriate reference has been given.

Susceptible interaction	Resistant interaction	Non-host interaction
Catechol o-methyltransferase ¹	S-adenosyl-L-methionine synthetase ¹	Novel - <i>no significant homology</i> (x2)
Guanine nucleotide binding protein	Actin ¹	Cysteine protease ⁴
Transaldolase	Receptor-like protein kinase 5 (x2) ²	Glutamate dehydrogenase (x2) ⁵
Novel - <i>no significant homology</i>	3-deoxy-D-arabino-heptulosonate-7-phosphate (DAHPS) ^{2,3}	
Jacalin / lectin		
¹ Pellegrini <i>et al.</i> , 1993		⁴ Bolwell, 1999
² Somssich and Hahlbrock, 1998		⁵ Osuji and Madu, 1996
³ Görlach <i>et al.</i> , 1995,		

The RDA process involves PCR amplification therefore the ordered libraries are expected to have some degree of redundancy for each EST. Additional screening to remove replicate ESTs will therefore be carried out before the library is used to characterize the cloned genes. The expression pattern of each EST will be confirmed by Northern analysis. Full length gene cDNAs will then be isolated, sequenced and if possible associated a gene function based on *in silico* analyses. Actual functional analysis will eventually be conducted using a transgenic approach. We will focus initially on the identification of novel genes that may be specific to our system, although we will also engage in projects to isolate and characterize associated regulatory sequences which may help us improve our knowledge of the integration and control of plant pathogen interactions.

There is thus a possibility that genes conferring both host and non-host resistance to *Polymyxa* spp. will be available for crop improvement in both sugar beet and cereals.

Acknowledgements

We would like to thank Dr. Mike Adams for supplying the *P. graminis* infected barley and acknowledge funding from the Biotechnology and Biological Sciences Research Council and British Beet Research Organization.

References

- Barr, K. J., Asher, M. J. C. and Lewis, B. G. (1995) Resistance to *Polymyxa betae* in wild *Beta* species. *Plant Pathology* 44, 301-307.
- Bolwell, G. P. (1999) Role of active oxygen species and NO in plant defence responses. *Current Opinion in Plant Biology* 2, 287-294.
- Chang, D. D., Park, N. H., Denny, C. T., Nelson, S. F. and Pe, M. (1998) Characterization of transformation related genes in oral cancer cells. *Oncogene* 16, 1921-1930.
- Eastwood, D. C., Kingsnorth, C. S., Jones, H. E. and Burton, K. S. (2001) Genes with increased transcript levels following harvest of the sporophore of *Agaricus bisporus* have multiple physiological roles. *Mycological Research* 105, 1223-1230.
- Fujisawa, I. and Sugimoto, T. (1979) Susceptibility of the wild sugarbeet species *Beta patellares*, *Beta corollinae* and *Beta vulgaris* to Beet necrotic yellow vein virus. *Proceedings of the Sugar Beet Research Association of Japan* 21, 31-38.
- Görlach, J., Raesecke, H. R., Rentsch, D., Regenass, M., Roy, P., Zala, M., Keel, C., Boller, T., Amrhein, N. and Schmid, J. (1995) Temporally distinct accumulation of transcripts encoding enzymes of the prechiasmata pathway in elicitor-treated, cultured tomato cells. *Proceedings of the National Academy of Sciences, U.S.A.* 92, 3166-3170.
- Heath, M. C. (2000) Nonhost resistance and nonspecific plant defenses. *Current Opinion in Plant Biology* 3, 315-319.
- Osuji, G. O. and Madu, W. C. (1996) Ammonium ion salvage by glutamate dehydrogenase during defence response in maize. *Phytochemistry* 42, 1491-1498.
- Paul, H., Henken, B., Debock, T. S. M. and Lange, W. (1992) Resistance to *Polymyxa betae* in *Beta* species of the section *procumbentes*, in hybrids with *Beta vulgaris* and in monosomic chromosome additions of *Beta procumbens* in *Beta vulgaris*. *Plant Breeding-Zeitschrift Fur Pflanzenzuchtung* 109, 265-273.
- Pellegrini, L., Geoffroy, P., Fritig, B. and Legrand, M. (1993) Molecular cloning and expression of a new class of ortho-diphenol-O-methyltransferases induced in tobacco (*Nicotiana tabacum*-L) leaves by infection or elicitor treatment. *Plant Physiology* 103, 509-517.
- Richard-Molard, M. and Cariolle, M. (2001) Water and abiotic stress and genetic improvement genetic progress in sugar beet. 64th Congress of the International Institute for Beet Research pp. 153-158
- Sambrook, J., Fritsch, E. F. and Maniatis, T. (1989) *Molecular Cloning. A laboratory manual*. Cold Spring Harbor, NY: Cold Spring Harbor Laboratory Press.
- Somssich, I. E. and Hahlbrock, K. (1998) Pathogen defence in plants - a paradigm of Biological complexity. *Trends in Plant Science* 3, 86-90.

RNA1 DETERMINES THE ABILITY OF *BARLEY YELLOW MOSAIC VIRUS 2* TO OVERCOME THE *RYM4* RESISTANCE GENE IN BARLEY

T. Kühne¹ and G. Proeseler²

Federal Centre for Breeding Research on Cultivated Plants, P.O. Box 1505, 06435 Aschersleben, Germany, ¹Institute of Resistance Research and Pathogen Diagnostics, ²Institute of Epidemiology and Resistance

Summary

The two *Polymyxa graminis* transmissible bymoviruses *Barley mild mosaic virus* (BaMMV) and *Barley yellow mosaic virus* (BaYMV) are known to cause the yellow mosaic disease in winter barley. While varieties carrying the recessive resistance gene *rym4* are fully protected against attacks of BaMMV and BaYMV1, the pathotype BaYMV2 is able to overcome the resistance causing a systemic infection. This raises the question, which of the two genomic RNAs determines the specific pathogenicity of BaYMV2. To find an answer, seedlings of two barley varieties harbouring the *rym4* gene were mechanically inoculated with a mixture of both BaYMV1 and BaYMV2. Using IC-RT-PCR and pairs of sequence specific primers the two isolates could be differentiated based on deletions with different size and position in their RNA2 molecules. The RNA1 fractions were distinguishable only on the basis of minor nucleotide sequence differences. In the case of RNA2, comparison of the PCR-fragments obtained from co-inoculated plants showed that leaves, in addition to RNA2 of BaYMV2, also contain that of BaYMV1 in similar amounts. In contrast, sequence analyses of the RNA1-specific amplicons confirmed exclusively the presence of RNA1 of BaYMV2 in co-inoculated plants. Concluding from these data the characteristic feature of this isolate to overcome the *rym4* resistance gene is determined by its RNA1.

Introduction

In Europe the yellow mosaic disease of winter barley was first described by Huth and Lesemann in 1978. *Barley mild mosaic virus* (BaMMV) and *Barley yellow mosaic virus* (BaYMV) were identified as the causal agents (Huth and Adams, 1990). Both viruses have a bipartite genome, induce the same type of symptoms in plants and are naturally transmitted by the plasmodiophoromycete *Polymyxa graminis*.

Very soon after the first description of the disease complex the recessive gene, *rym4*, was detected in several barley varieties and mapped to the distal region of the long arm of chromosome 3H (Graner and Bauer, 1993). It confers to the plants immunity to both viruses. For almost 20 years, *rym4* was the only available resistance gene in the assortments of barley and it is now prevalent in the commercially grown varieties. More than a decade ago a pathotype designated as BaYMV2 was detected in field grown plants that was able to overcome the *rym4*-specific resistance (Huth, 1989). Despite numerous activities in the past, even today this pathotype can be distinguished from the original form (BaYMV1) only based on its biological properties. All attempts for differentiation by means of serological and molecular techniques have failed so far (Hariri *et al.*, 1996; Shi *et al.*, 1996). Thus, it is still unknown, which alterations in the genome of BaYMV2 determine its pathogenicity towards resistant varieties. In a first approach to elucidate this problem we wanted to find out, which of the two genomic RNAs is coding for this trait.

Materials and Methods

The two isolates, BaYMV1-ASL and BaYMV2-GB, originate from different infested fields in Germany. They have been maintained in climate chambers on barley plants by serial mechanical passages for about 10 years. Serological detection was performed by DAS-ELISA. To amplify fragments of the viral genome by IC-RT-PCR, crude sap from infected leaves was incubated overnight at 4 °C in tubes that were pre-coated with BaYMV IgG. Applying sequence specific primers the RNA was transcribed and amplified by PCR. The obtained DNA fragments were separated electrophoretically, extracted from the agarose gel, ligated into the vector pGEM-T (Promega) and subsequently sequenced in both orientations on a ALF-Express automated sequencer (Pharmacia) using Cy5-labelled primers and a ThermoSequenase Cycle Sequencing Kit (Amersham Pharmacia Biotech). Sequence data were processed by means of the software package Vector NTI 6 (Informax Inc.).

Results and Discussion

It has been known for several years that bymoviruses like other fungal transmitted viruses can undergo spontaneous deletions in the P2 coding region of the RNA2 if they are maintained without *P. graminis* by serial mechanical passages under controlled conditions (Timpe and Kühne, 1994, 1995; Dessens *et al.*, 1995). Based on size and the position of the deleted fragment different isolates, like BaYMV1-ASL and BaYMV2-GB can be readily identified and differentiated by PCR (Fig. 1).

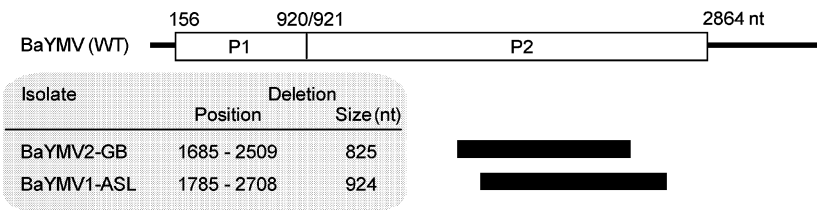

Fig. 1. Schematic organisation of RNA2 of BaYMV wild type (WT). Black bars indicate position and size of deleted regions in the isolates BaYMV2-GB and BaYMV1-ASL.

Upon amplification of a region flanked by the nucleotide positions 1283 and 2992 in the wild type (undeleted) form of the virus, BaYMV1-ASL and BaYMV2-GB reveal DNA fragments of reduced length with 785 bp and 884 bp, respectively. Following mechanical co-inoculation of seedlings of the susceptible barley variety 'Corona', it was investigated whether RNA2 molecules of both deletion mutants may be present in the same leaf of individual plants, thus indicating a mixed infection. According to figure 2, the two forms may occur in single leaves separately or together, which was confirmed by sequence analysis of the PCR fragments re-isolated from the gel.

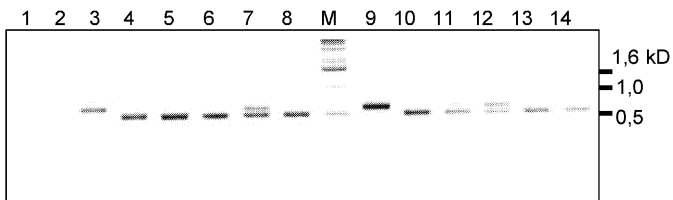

Fig. 2. Electrophoresis of PCR-amplified RNA2 fragments from single leaves of individual plants of the susceptible variety 'Corona' co-inoculated with BaYMV2-GB and BaYMV1-ASL. 1:H₂O, 2:non-inoculated plant, 3:plant/BaYMV2-GB, 4:plant/BaYMV1-ASL, 5-14:plants/BaYMV2-GB+BaYMV1-ASL, M: marker.

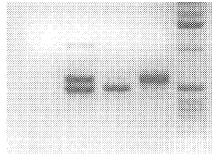

Fig. 3. Electrophoresis of IC-RT-PCR amplified RNA2 fragments from single leaves of resistant plants ('Express') co-inoculated with BaYMV2-GB and BaYMV1-ASL. 1 - H₂O, 2-4 - co-inoculated plants, M – marker.

Unlike 'Corona' the varieties 'Express' and 'Carola' carry the resistance gene *rym4* that confers resistance to BaYMV1 but does not prevent infection with BaYMV2. Genotype HHOR 4201 shows the same behaviour in relation to the virus isolates but it does not reveal the *rym4*-specific PCR product when the microsatellite primer Bmac 029 is applied (Krämer, personal communication). It may have a different genetic background of resistance.

Twenty five seedlings in the 3-leaf stage of each resistant genotype were inoculated with the two virus isolates either separately or in combination. Six weeks after inoculation with BaYMV1-ASL no infection was detectable in any case, plants remained symptomless, ELISA and PCR tests were negative. In contrast to that, the genotypes became infected with BaYMV2-GB. Upon co-inoculation the picture resembled that of the susceptible variety 'Corona' – single leaves contained the RNA2 fragments typical for the two isolates either separately or in combination. The results are shown in figure 3 for the variety 'Express'. This is the first experimental proof that RNA2 of BaYMV1 is able to replicate and spread inside resistant barley genotypes if the plants at the same time are infected with BaYMV2. Concluding from the bands in agarose gels the concentration of the RNA2 of both pathotypes in the leaves is similar.

What is the situation in case of RNA1? To answer this question, overlapping PCR derived fragments of the RNA1 were sequenced starting at the 5' end to identify a region with clear differences in the calculated amino acid sequence between both isolates. The VPg gene and the 5' half of the gene coding for the N1a proteinase appeared suitable. All primers were designed based on the published sequence for the German isolate BaYMV1 - MPI (accession number X69757, Peeren-boom *et al.*, 1992). Figure 4 presents the result of sequence alignment on the amino acid level for both BaYMV1-ASL and BaYMV2-GB for the indicated region of RNA1. The following pairs of primers were used for amplification: 15/P16 (5'-GCTGTTGAGAGCAAACCTATGTG-3' / 5'-GAAACTGTCCTCGGTGTTCT-3') and P17a/P18 (5'-CATCAGCGGAAGCTACTAGAAGAAA-3' / 5'-TGGTTCCTCAATAGCAAAAAG-3').

Fig. 4. Comparison of calculated amino acid sequences of the isolates BaYMV2-GB and BaYMV1-ASL with BaYMV1-MPI (acc. number X69757) in the region corresponding to VPg (solid line) and N-terminus of N1a-proteinase (broken line).

Based on this plant no. 2 (see fig. 3) and no. 10 of the variety 'Express' that had been co-inoculated with the two isolates and tested positive for the presence of both RNA2 forms were selected to amplify the RNA1 specific fragments. Because the amplicons are of identical size and cannot be differentiated in

agarose gels, they were re-isolated, cloned and sequenced. For each primer pair and each plant, 5 individual clones were sequenced in both orientations. The obtained data confirmed the presence of the RNA1 of BaYMV2-GB in the infected leaves. None of the sequences corresponded to BaYMV1-ASL.

Concluding from these data, the pathogenicity of BaYMV2-GB towards the barley varieties 'Express' and 'Carola' harbouring the *rym4* gene, as well as towards the resistant genotype HHOR 4201 with a still unknown genetic background, is determined by the RNA1. This component accepts the RNA2 of the isolate BaYMV1-ASL as a target and supports its replication and movement in resistant plants. In contrast, there was no evidence for replication of RNA1 of BaYMV1-ASL in co-inoculated seedlings of the resistant barley genotypes. Basing on a different experimental approach these results can confirm previous findings for BaMMV (Kashiwazaki *et al.*, 1996). The question whether the observed sequence differences in the RNA1 of the pathotypes can be attributed to their pathogenicity, cannot be answered yet.

Acknowledgements

We thank Ms. Doris Walther and Heldgard Weidling for excellent technical assistance.

References

- Dessens, J. T., Nguyen, M., and Meyer, M. (1995). Primary structure and sequence analysis of RNA2 of a mechanically transmitted *Barley mild mosaic virus*, isolate: an evolutionary between bymo- and furoviruses. *Arch. Virology* 140, 325-333.
- Graner, A., and Bauer, E. (1993). RFLP mapping of *therym4* virus resistance gene in barley. *Theor. Appl. Genet.* 86, 689-693.
- Hariri, D., Lapiere, H., Filleur, S., Ploive, C., and Delaunay, T. (1996). Production and characterization of monoclonal antibodies to *Barley yellow mosaic virus*, and their use in detection of four bymoviruses. *J. Phytopathol.* 144, 331-336.
- Huth, W. (1989). Ein weiterer Stamm des *Barley yellow mosaic virus*, gefunden. *Nachrichtenbl. Dt. Pflanzenschutzd.* 41, 6-7.
- Huth, W., and Adams, M.J. (1990). *Barley yellow mosaic virus*, (BaYMV) and BaYMV-M. two different viruses. *Intervirology* 31, 38-42.
- Huth, W., Lesemann, W. D., and Paul, W. L. (1984). *Barley yellow mosaic virus*: Purification, electron microscopy, serology and other properties of two types of the virus. *Phytopathol. Z.* 111, 37-54.
- Huth, W., and Lesemann, D. (1978). Eine für die Bundesrepublik neue Virose an Wintergerste. *Nachrichtenbl. Dt. Pflanzenschutzd.* 30, 184-185.
- Kashiwazaki, S., and Hibino, H. (1996). Genomic reassortment of *Barley yellow mosaic virus*, evidence for the involvement of RNA1 in pathogenicity. *J. Gen. Virol.* 77, 581-585
- Peerenboom, E. Pröls, M. Schell, J. Steinbiß, H.-H. Davidson, A.D. (1992). The complete nucleotide sequence of RNA1 of a German isolate of *Barley yellow mosaic virus*, and its comparison with a Japanese isolate. *J. Gen. Virol.* 73, 1303-1308.
- Shi, N. N., Chen, J. P., Wilson, T. M. A., Macfarlane, S. A., Antoniw, J. F., and Adams, M. J. (1996). Single-strand conformation polymorphism analysis of RT-PCR products of UK isolates of *Barley yellow mosaic virus*. *Virus Res.* 44, 1-9.
- Timpe, U., and Kühne, T. (1994). The complete nucleotide sequence of RNA2 of *Barley yellow mosaic virus*, (BaMMV). *Eur. J. Plant Pathol.* 100, 233-241.
- Timpe, U., and Kühne, T. (1995). *In vitro* transcripts of a full-length cDNA of a naturally deleted RNA2 of *Barley yellow mosaic virus*, (BaMMV) replicate in BaMMV-infected plants. *J. Gen. Virol.* 76, 2619-2623.

VIRUS RESISTANCE IN TRANSGENIC PLANTS EXPRESSING *BET* NECROTIC YELLOW VEIN VIRUS COAT PROTEIN READTHROUGH DOMAIN

Andika, I. B., Kondo, H., Suzuki, N. and Tamada, T.

Research Institute for Bioresources, Okayama University, Kurashiki, 710-0046 Japan

Summary

The 5'-terminal cistron of *Beet necrotic yellow vein virus* RNA2 contains two ORFs encoding the coat protein (CP, 21kDa) and its readthrough protein domain (RTd, 54 kDa) produced by translational readthrough of the CP stop codon. *Nicotiana benthamiana* plants transformed with the RTd frequently obtained one of two types of resistance to virus inoculation: high resistance (no virus infection) and recovery. In recovery line plants, newly developing leaves 3 to 4 weeks after virus inoculation were symptomless, virus free, and resistant to virus reinoculation. No or little accumulation of the transgene mRNA was detected in plants of highly resistant lines, whereas plants of recovery lines accumulated a detectable level of transcript. After virus inoculation, the transcript accumulation in recovered leaves was, however, greatly reduced to the level of highly resistant plants. Two or more copies of the transgene were detected in plants of highly resistant and recovery lines, although susceptible line plants contained single copies. These results suggested that the strong resistance in BNYVV 54 kDa RTd transgenic plants was mediated by RNA silencing, whereas the recovery phenotype was mediated by virus-induced RNA silencing.

Introduction

The strategy of transforming plants with sequences derived from viral RNA has proved to be successful in generating resistance to many viruses in several plant species (Baulcombe, 1996). The two most common sequences used for the generation of virus-resistant plants are viral coat protein and replicase sequences. However, it seems likely that all viral sequences have a potential to induce resistance through mechanisms of post-transcriptional gene silencing.

Beet necrotic yellow vein virus (BNYVV) is the causal agent of the rhizomania disease of sugar beet and transmitted by the soil-borne fungus *Polymyxa betae*. The disease is now distributed in many sugar beet growing countries and economically important, not only because it causes a severe loss in sugar yield but also because it is difficult to control (Asher, 1993). Therefore, the cultivation of resistant or tolerant cultivars is the most promising way to control this viral disease.

The genome of BNYVV consists of five RNA components. RNA1 and RNA2 are required for viral RNA replication, assembly, virus movement and transmission, whereas RNA3 and RNA4 or additionally RNA5 are needed for disease development and spread in nature (Richards and Tamada, 1992). The 5'-proximal open reading frame (ORF) of RNA2 encodes the 21kDa coat protein (CP). The CP cistron is separated from a long (54 kDa) inphase ORF by a single amber terminal codon which is suppressed about 10 % of the time to produce a CP-54 kDa fusion protein of 75 kDa (readthrough protein). The 75 kDa readthrough protein is involved in virus assembly and fungus transmission (Richards and Tamada, 1992). In this paper, *Nicotiana benthamiana* plants were transformed with the 54 kDa CP readthrough domain (RTd). Two types of resistant plants, high resistance and recovery, were obtained, and molecular analysis reveals that such resistance is mediated by the RNA silencing.

Materials and Methods

Virus inoculation and plants

The BNYVV-O11 isolate was used in this study and maintained in *N. benthamiana*. The virus was transmitted by manual inoculation in which freshly extracted sap from infected *N. benthamiana* plants was rubbed onto Carborundum-dusted leaves. Virus infections were identified by symptom expression and by ELISA. *N. benthamiana* plants were grown in special test tubes which contained quartz sand in a growth cabinet at 24 °C with a 16 hr supplemented photoperiod.

Vector contraction and plant transformation

The 54 kDa RTd of BNYVV-O11 was cloned by RT-PCR methods. The binary vector construct was constructed by replacing the GUS gene of the pBI121 binary vector with the fragment corresponding to RTd. The plasmid construct was transformed into *Agrobacterium* cell strain LBA4404 which then used to inoculate leaf disks of *N. benthamiana*. Plant transformation was conducted as described by Topping (1998) with a slight modification. The presence of inserted genes in transgenic plants was confirmed by PCR of total genomic DNA using primers specific for CaMV 35S promoter and nopaline synthase termination.

DNA blot analysis

Genomic DNA was extracted from leaf material using CTAB. Twenty µg of DNA was digested with *Hind*III followed by gel electrophoresis, transfer onto Hybound N⁺ membrane (Amersham) and Southern hybridization. DNA fragments for use as probes were labeled with DIG-dUTP via PCR (Boehringer Mannheim).

RNA blot analysis: Total RNA was extracted by phenol-based method (Verwoerd et al., 1989), from which poly(A⁺) RNA fraction was isolated using mRNA Isolation Kit (Boehringer Mannheim) and 6 µg poly(A⁺) RNA was used for Northern blot analysis. Hybridization was done with DIG-labeled DNA probes.

Results and Discussion

Transformation of Nicotiana benthamiana

N. benthamiana leaf tissue was transformed with *Agrobacterium tumefaciens* carrying a binary vector containing the 54 kDa RTd. Thirty-two primary transgenic plants (T₀) were obtained, from which self-fertilized seed (T₁) was collected. T₁ seed from 18 lines selected were used for resistance tests. The presence of inserted genes in transgenic plants (T₀) of 18 lines was confirmed by PCR.

Screening for virus resistance

Five to 19 plants of each of the 18 lines (T₁) were challenged by manual inoculation with sap from plants infected with BNYVV-O11. Within two weeks after inoculation, all the non-transgenic control plants displayed visible symptoms of BNYVV infection, whereas inoculated transgenic plants showed three phenotypes of symptoms. First phenotype was highly resistant plant, in which the virus was not detected in inoculated leaves and upper leaves. Virus was occasionally detected in inoculated leaves, but no systemic infection. Second phenotype was recovery plant, in which systemic symptoms appeared within two weeks after inoculation, but newly developing young leaves 3 to 4 weeks later were symptomless and virus free. Third phenotype was susceptible plant, in which symptoms are similar to those of nontransgenic control plants. Inoculated plants were also assayed by ELISA. Virus was detected by ELISA in upper leaves of nontransgenic control and transgenic plants a few days before systemic symptoms appear. In resistant transgenic plants, however, virus was never detected in upper leaves showing no

symptoms, but only a trace amount of virus was occasionally detected in inoculated leaves in some lines.

Table 1 shows the results of phenotypes of T₁ plants in each of the 18 lines to manual inoculation with BNYVV. The majority of plants of 6 lines (RT1, RT2, RT3, RT14, RT24 and RT31) showed the resistance phenotype. Nine lines (RT4, RT6, RT8, RT9, RT10, RT18, RT20, RT22 and RT25) included the recovery phenotype, but in RT6, RT10, RT20 and RT22 lines, susceptible and recovery plants were about half-and-half. Three lines (RT7, RT13 and RT 15) were susceptible to BNYVV infection. The presence of inserted genes in these plants was confirmed by PCR.

Table 1. Phenotypes of T₁ transgenic plants to manual inoculation with BNYVV

Line	Total plants tested	Response to inoculation with BNYVV		
		Susceptible	Recovery	Resistant
RT1	19	5	1	13
RT2	12	1	0	11
RT3	16	0	0	16
RT4	6	1	5	0
RT6	12	5	7	0
RT7	8	8	0	0
RT8	8	0	8	0
RT9	10	1	9	0
RT10	10	6	4	0
RT13	10	10	0	0
RT14	10	2	0	8
RT15	12	11	1	0
RT18	5	0	5	0
RT20	5	2	3	0
RT22	5	2	3	0
RT24	5	0	0	5
RT25	5	0	5	0
RT31	5	0	1	4
Control	25	0	0	0

Homogeneous T₂ transgenic plant lines from each of two resistant lines (RT24 and RT14), three recovery lines (RT25, RT8 and RT9) and two susceptible lines (RT7 and RT13) were selected and used for further detail analysis.

At 25 days after inoculation, recovered leaves of plants of lines RT25-1 and RT8-2 were reinoculated with BNYVV and analyzed by ELISA two weeks later. No virus was detected in the reinoculated leaves or younger leaves of recovered plants, although virus was detected in older leaves showing symptoms with initial infection. This indicates that recovered plants become resistant to BNYVV infection.

Molecular analysis of transgenic plants

To determine the transgene copy number in plants of representative transgenic lines, Southern blots of genomic DNA, digested with *Hind*III, were analyzed with transgene probes flanking the restriction site. Two or more copies of the transgene were detected in plants of resistant lines (RT24-1, RT14-4 and RT3-1) and recovery lines (RT25-1, RT8-2 and RT9-1), whereas plants of susceptible lines (RT7-2 and RT13-2) contained single copies.

Northern blot analysis was performed on total RNA preparation from plants of representative transgenic lines, but no transgene transcripts were detected. Therefore, poly(A) fraction from total RNA was used for materials for hybridization. The results indicated that plants of recovery lines (RT25-1, RT8-2 and RT9-1) accumulated a detectable level of transcript, whereas no or little accumulation of the transgene mRNA was observed in plants of resistant lines (RT24 and

RT14) and susceptible lines (RT7-2 and RT13-2). However, the transcript accumulation in recovered leaves after inoculation greatly reduced to the level of highly resistant plants.

In this paper, we provide evidence that *N. benthamiana* plants transformed with the 54 kDa CP RTd of BNYVV frequently obtained one of two types of resistance to virus infection: one is high resistance phenotype, and the other is recovery phenotype. In recovery lines, newly developing leaves 3 to 4 weeks after virus inoculation were symptomless and virus free, and resistant to virus reinoculation. From analysis of transgene copy number, transgene mRNA levels, and transgene DNA methylation levels, we conclude that the high resistance in transgenic plants was mediated by the RNA silencing, whereas the recovery phenotype was mediated by the virus-induced RNA silencing.

This provides first evidence that a novel type of resistance to BNYVV was obtained by transformation of the CP RTd, which all fungus-borne rod-shaped viruses (*Benyvirus*, *Furovirus*, *Pecruvirus* and *Pomovirus*) are encoded. This type of resistance to BNYVV will have important implications for control of BNYVV in sugar beet crop and also for control of other soilborne viruses.

References

- Asher, M. J. C. (1993). Rhizomania. In: The Sugar Beet Crop: Science into Practice. D. A. Cooke and R. K. Scott, eds. Chapman and Hall, London. pp. 311-346.
- Baulcombe, D. C. (1996). Mechanisms of pathogen-derived resistance of viruses in transgenic plants. *Plant Cell* 8: 1833-1844.
- Richards, K.E. and Tamada, T. (1992). Mapping functions on the multipartite genome of *Beet necrotic yellow vein virus*. *Annu. Rev. Phytopath.* 30: 291-313.
- Topping, J. F. (1998). Tobacco transformation. In: G. D. Foster and S. C. Taylor. eds. Plant Virology Protocols: From Virus Isolation to Transgenic Resistance, *Methods in Molecular Biology* 81. pp. 365-372.
- Verwoerd, T. C., Dekker, D. M. M. and Hoekema, A. (1989). A small-scale procedure for the rapid isolation of plant RNAs. *Nucleic Acids Res.* 17: 2362.

EFFECT OF ENVIRONMENTAL FACTORS ON INFECTION OF POTATO BY *SPONGOSPORA SUBTERRANEA* F.SP. *SUBTERRANEA*, THE VECTOR OF PMTV

P. van de Graaf, A. Lees and J. Duncan

Scottish Crop Research Institute, Invergowrie, Dundee DD2 5DA, UK

Summary

Potato mop top virus (PMTV), a cause of spraing in potatoes, is transmitted by the plasmodiophorid organism *Spongospora subterranea* f.sp. *subterranea*, the cause of potato powdery scab. Gaps in the current knowledge of the biology of *S. subterranea* f.sp. *subterranea* are preventing the development of effective disease control methods. A study was conducted to examine the effects of soil inoculum level, temperature, soil type and soil moisture regime on the infection of potato tubers and roots by *Spongospora* in pot tests. The amount of *Spongospora* inoculum added to the soil was found to have no significant effect on the level of infection or disease. More DNA of the vector of PMTV was detected in tuber tissues at 9°C than at higher temperatures (12 and 17°C), but root infection levels were not greatly influenced by temperature. Tuber and root infection levels were higher in sand and loam soils compared with clay soil. In soil kept at constant dampness, the amounts of *Spongospora* DNA in the tubers and roots of host plants were higher than in soil with a fluctuating moisture regime. These findings have contributed to a better understanding of the biology of *S. subterranea* f.sp. *subterranea* and will help further studies on the prevention and control of both powdery scab and spraing caused by PMTV.

Introduction

Potato mop top virus (PMTV), a cause of spraing in potato, is the type member of the genus *Pomovirus*. It causes brown lines and marks in the flesh of tubers of susceptible varieties infected during the growing season, and yellow chevrons and shortening of internodes of stems of plants grown from infected tubers. Tuber yield and quality can be severely affected with losses of up to 20% (Stevenson et al., 2001).

The vector of PMTV is *Spongospora subterranea* f.sp. *subterranea*, a plasmodiophorid organism and the cause of powdery scab and root galling in potato (Jones and Harrison, 1969). Powdery scab is especially prevalent in cool, wet climates (Wale, 2000), but the exact effect of temperature and moisture on the incidence and spread of infection is unknown. Other areas of the biology of the vector of PMTV, such as the effect of soil type on infection, and the occurrence of latent infections are also poorly understood. Spraing caused by PMTV is regularly found in plants without powdery scab symptoms, which suggests that latent tuber infections by *S. subterranea* could be common (Jones and Harrison, 1969; Wale, 2000).

A real-time PCR (TaqMan®) assay specific to *S. subterranea* f.sp. *subterranea* has recently been developed and is a quick and reliable method for detecting and quantifying *Spongospora* DNA in host plant tissues (van de Graaf et al., 2002). Use of this method in studies on *S. subterranea* f.sp. *subterranea* could greatly increase our knowledge on the biology of this pathogen and virus vector. A better understanding of *S. subterranea* f.sp. *subterranea* will eventually lead to improved prevention and control of both powdery scab and spraing caused by PMTV. The objective of this work was therefore to study the effect of soil inoculum level and several environmental factors on the infection of potato by *S. subterranea* f.sp. *subterranea*.

Materials and Methods

Powdery scab lesions containing sporeballs were scraped off the surface of diseased Scottish potato tubers with a scalpel and collected in a mortar. The scabs were ground with a pestle and the resulting powder was passed through a 53 μm mesh sieve and suspended in water. The concentration of the sporeball solution was established microscopically using a haemocytometer. Sand, loam and clay field soils were air dried and sieved (1 cm). Standard water column and pressure plate techniques were used to obtain soil moisture curves for each soil type.

Water was added to batches of the three types of soil to bring the moisture level to either dampness (-1 bar) or saturation. Different numbers of sporeballs were present in the water added to the soils resulting in inoculum concentrations of 5, 15 or 50 sporeballs per g soil. Soil moistened with water without sporeballs was used for the control treatments. The water and soil were mixed thoroughly by hand and distributed into 3 litre pots. A seed tuber of potato cv. Estima (susceptible to powdery scab) was planted in each pot and placed in a growth room with a 16 h light regime at a constant temperature of 12°C. Additional treatments with loam soil were carried out at 9 and 17°C. Five replicates were used per treatment. The pots containing damp soil were watered with distilled water on a regular basis to keep the soil at a constant moisture level, while pots containing saturated soil were left to dry out for ten days and then saturated again. This procedure was repeated until the end of the experiment. Plants were harvested at two growth stages: tuber initiation and maturity.

The progeny tubers of each potato plant were collected, washed, visually inspected for powdery scab symptoms, and peeled. Powdery scab symptom severity was determined on the basis of the percentage tuber surface area affected by powdery scab using the scale published by Merz (2000), which runs from 1 = 'no symptoms' to 7 = '>75% surface area covered with powdery scab'. The peelings from each plant were bulked, air dried, and then stored in the freezer before DNA extraction. Disease scores per tuber were averaged per plant. The roots of each plant were harvested, washed and visually assessed for symptoms of root galling using the scale given in Table 1. They were then air dried and stored in the freezer before DNA extraction.

Score	Symptoms observed
0	no root galls
1	one or two root galls
2	several galls, mostly small (< 2 mm in diameter)
3	many galls, some > 2 mm in diameter
4	most major roots with galls, some or all > 4 mm in diameter

Table 1. Scale for visual assessment of potato root gall severity.

DNA was extracted from the potato tuber peelings and roots using a Nucleon® PhytoPure plant DNA extraction kit. The dry weight of the samples was noted and the sample size was reduced if the weight was more than 0.1 g. Real-time quantitative PCR was performed in an ABI Prism 7700 Detection System (TaqMan®) using the DNA from tuber peelings or roots with primers and a probe specific for *S. subterranea* f.sp. *subterranea*. The universal thermal protocol recommended by PE Applied Biosystems (Anonymous, 1998) was used for the amplification of 1 μl template DNA in a 24 μl reaction mix. A range of standards containing known amounts of DNA from *S. subterranea* f.sp. *subterranea* was included in the assay and used to determine the amount of *S. subterranea* f.sp. *subterranea* DNA in the unknown samples. A non-template control was included in every assay and all samples were tested in duplicate. Scores were adjusted in relation to the original weight of the sample used for extraction. Plants were scored as infected if pathogen DNA was detected. All data were analysed using the appropriate statistical tests ($\alpha = 0.05$).

Results

No significant relationship was found between the number of sporeballs added to the soil and the level of infection of potato tubers or roots by *Spongospora*. At maturity, the highest levels of pathogen DNA in tubers and roots were found in plants in soil with 50 sporeballs per g soil. However, any differences in infection or disease levels found between the treatments with 5, 15 and 50 sporeballs per g soil were usually not significant. No effect of inoculum level on the percentage of plants with either powdery scab symptoms or root galling was found, but the percentage of mature plants with latently infected tubers appeared to depend on inoculum level. In the control, more than 40% of the plants with infected tubers did not show powdery scab. The percentage of infected plants with latent infections in soils inoculated with sporeballs was between 24 and 27%. However, none of the inoculum effects observed were statistically significant. Low levels of tuber (8% of plants) and root symptoms (1% of plants) were found in the non-inoculated control, but the incidence and severity of powdery scab and root galling at maturity were almost always significantly higher in the inoculated soils than in the controls.

The incidence and severity of tuber and root infection were generally higher at lower temperatures, but this effect was not significant. The majority of root samples from mature plants tested negative for infection by *Spongospora* and the DNA levels detected were especially low at 17°C. Powdery scab severity at maturity was significantly higher at 12°C than at 9°C and a large number of infected tubers, especially at 9°C, did not develop powdery scab symptoms. The effect of temperature on root galling was very different from that on powdery scab. Whereas no root galls were found at 9°C and only a few at 12°C, they were significantly more common and severe at 17°C.

Tuber and root infection as well as powdery scab and root gall symptoms were more severe in lighter soils, but no significant differences were found between the three soils tested. At tuber initiation, powdery scab occurred only in plants in sand and loam. The amount of DNA extracted from tuber skins was highest for sandy soil at both growth stages, but powdery scab at maturity was no more severe than in loam soil. Infection and disease severity were relatively low in clay soil but the differences with the two other soil types were generally not significant. Only powdery scab severity was significantly lower in clay soil compared with the sand and loam soils. Because the effect of soil type was tested at 12°C, very few root galls were found in the two lighter soils and almost no galls were formed by plants growing in clay soil. Only in sandy soil were powdery scab symptoms (18% of plants) observed in the non-inoculated treatments.

At maturity, tuber infection and powdery scab symptoms were significantly more severe in inoculated soil kept at constant dampness than with fluctuating wetness. Root infection and disease levels were also higher at constant dampness, but only root gall severity differed significantly between the two soil moisture regimes.

The majority of plants grown in inoculated soil were infected by *S. subterranea* f.sp. *subterranea* at an early stage. DNA of the pathogen was detected in around 80% of plants (tuber and/or roots) at tuber initiation. The percentage of plants with infected tubers did not increase during growth, although the average amount of DNA detected in tuber peelings was significantly higher at maturity as were the incidence and severity of powdery scab and root galling. The detection of root infection at maturity was less successful than at tuber initiation. Latent tuber infections were especially common at tuber initiation when symptoms were yet to develop in most cases. However, even at maturity more than 15% of plants with infected tubers did not show powdery scab symptoms.

Discussion

Important new information on the biology of *S. subterranea* f.sp. *subterranea*, which contributes to a better understanding of this pathogen and PMTV vector and thus hopefully to

more effective prevention and control measures for powdery scab and spraing, has been demonstrated. The lack of a significant effect of soil inoculum level on tuber and root infection levels can be explained by the fact that once initial infection has been established, secondary zoospores released from zoosporangia greatly reduce the importance of soil inoculum (Burnett, 1991). In our trials, *Spongospora* infection levels were high for most treatments, which would have meant a high chance of virus transmission if PMTV had been present. The incidence of infection and disease in non-inoculated soils could have been the result of natural contamination of the soil or the seed tubers with *Spongospora*.

The different effect of temperature on the development of disease symptoms on tubers and roots was previously unknown and the incidence of high levels of powdery scab even at temperatures as low as 9°C was unexpected. Unlike disease incidence, the occurrence of tuber and root infection was not significantly affected by temperature, which suggests that the germination of sporeballs might not be greatly influenced by temperature. This could be of importance to both PMTV transmission and the development of latent tuber infections by *Spongospora*. Latent tuber infections were first observed by Diriwächter and Parbery (1991), and appear to be associated particularly with low temperature and low inoculum levels. Their existence may explain why spraing caused by PMTV regularly develops in tubers without powdery scab symptoms (Jones and Harrison, 1969; Wale, 2000).

The soil moisture results showed that the moisture level of the soil does not need to be high to obtain high levels of infection by *S. subterranea*. Low infection levels in soils with fluctuating wetness could have been due to the compactness of the soils as a result of the moisture regime. In some countries, powdery scab is a particular problem in sandy and loamy soils (Wale, 2000), and our results agree with these field observations. The pore size of clay soil is small and the resulting low oxygen levels could have played a role in preventing high levels of infection.

Acknowledgements.

Funding of this work by the Scottish Executive Environment & Rural Affairs Department and the British Potato Council is gratefully acknowledged. Many thanks are due to Dr. Danny Cullen (SCRI) for designing the TaqMan® primers and probe. The authors would like to thank Louise Sullivan, Sandie Linton, Alison Ward and Leanne Brown for technical assistance, and Dr. Paul Hallett (SCRI) for assistance with soil moisture curve measurements.

References

- Anonymous (1998). TaqMan® Universal PCR Master Mix Protocol. PE Applied Biosystems, Foster City, CA, USA.
- Burnett, F. (1991). The Biology and Control of Powdery Scab (*Spongospora subterranea*) of Potatoes. PhD thesis, University of Aberdeen, Aberdeen, UK.
- Diriwächter, G. and Parbery, D.G. (1991). Infection of potato by *Spongospora subterranea*. Mycol. Res. 95, 762-764.
- Jones, R.A.C. and Harrison B.D. (1969). The behaviour of *Potato mop-top virus* in soil, and evidence for its transmission by *Spongospora subterranea* (Wallr.) Lagerh. Ann. appl. Biol. 63, 1-17.
- Merz, U. (2000). Powdery scab. Research in Switzerland. In "Proceedings First European Powdery Scab Workshop, SAC, Aberdeen, Scotland, July 20-22, 2000" (U. Merz and A.K. Lees, Eds), pp. 67-71.

POSSIBLE ROLE OF INDUCED PROTEINS DISPLAYING CHITINASE AND β -1,3-GLUCANASE ACTIVITIES IN RESISTANCE TO RHIZOMANIA

L. Burketova¹, K. Stillerova², M. Sindelarova¹

¹ Institute of Experimental Botany, Academy of Sciences of the Czech Republic, Prague, Czech Republic

² Czech University of Agriculture Prague, Kamycka 957, 165 21 Prague, Czech Republic²

Summary

Defence responses of sugar beet plants against rhizomania disease development were studied in 3-week-old plants of susceptible cultivar Hilma. Infection of plants with *Beet necrotic yellow vein virus* (BNYVV) and/or its vector *Polymyxa betae* resulted in the accumulation of two defence proteins; a basic β -1,3-glucanase class II (Glu2) and a basic chitinase class IV (Ch4). Both enzymes were deposited extracellularly mainly in the cell walls and extracellular matrix of endodermis and adjacent cells of cortex. Ch4 was also found in xylem vessels. The colocalisation of BNYVV and *P. betae* with the enzymes was studied on a consecutive cross-sections of infected roots. Staining for the Ch4 and Glu2 partly corresponded to the cells infected with BNYVV but the signal was found also in parts distant from BNYVV infected cells. As the signal for Ch4 and Glu2 in healthy plants was none or weak, it is likely that the hydrolases play a role in the resistance of sugar beet against rhizomania.

Introduction

Rhizomania, an important disease of sugar beet (*Beta vulgaris* L.), is caused by *Beet necrotic yellow vein benyvirus* (BNYVV) and/or *Beet soilborne pomovirus* (BSBV), both transmitted by the soil organism *Polymyxa betae* Keskin (Plasmodiophoraceae). Resting spores of the vector (cystosori) containing virus particles survive in soil for many years, hamper successful combating of the disease. Possibility for sugar beet protection against rhizomania is still limited. Besides classical gene-for-gene concept based on the interaction between plant and pathogen resistance (*R*)/avirulence (*Avr*) gene products, plant's own defence mechanisms could be exploited in normally susceptible plants. This phenomenon termed "systemic acquired resistance" (SAR), utilizes the fact, that pathogens, pathogen-derived elicitors, and some chemical inducers are capable of inducing increased level of resistance to subsequent infection with fungi and viruses (Kuc, 1995). Transcriptional activation of defence genes occurs both at the site of infection/induction and at distant parts of the plant. Among main defence genes belong those encoding pathogenesis-related (PR) proteins. For the majority of PR families, activities are known e.g. PR-2 proteins with β -1,3-glucanase activity and PR-3 with chitinase activity, able to cleave basic compounds of cell walls of fungal pathogens *in vitro* as well as *in vivo* (Kuc, 1995; Wubben *et al.*, 1992).

The aim of our work was to find out the role of β -1,3-glucanase and chitinase in the resistance to rhizomania.

Methods

Plants. Sugar beet (*Beta vulgaris*) plants cv. Hilma were grown in pots filled with Perlite, and regularly watered with a half strength Steiner nutrient solution, in growth chamber set as follows: day temperature 24°C; night temperature 18°C; 16 h photoperiod (photon flux density of 60 $\mu\text{mol}^{-2} \text{s}^{-1}$).

Inoculation. 3-week-old plants were inoculated by adding suspension of *P.betae* zoospores containing BNYVV to roots.

Fixation and immunohistology. Four days following the induction, both leaf and root samples were collected, fixed by immersion in 3 % paraformaldehyde and 0,5 % glutaraldehyde in PBS for 1 h at room temperature under vacuum and 3 h at 4°C. The samples were subsequently washed with PBS, dehydrated in graded saccharose series (from 0,1 M to 1,76 M) at 4°C and frozen at –80°C. Tissues sections were transferred to 15 % gelatine, sections of 6 µm were cut on cryostat and collected sample sections rehydrated in declining saccharose series (from 1,76 M to 0,1 M). Then the sections were preincubated in 1 % sheep serum albumin for 30 min followed by incubation with specific polyclonal antibodies (raised against Ch2 and Glu2; a kind gift from Danisco, Denmark). After washing in TBS, the sections were incubated with secondary goat anti-rabbit antibody coupled to alkaline phosphatase. Visualisation of alkaline phosphatase activity was made with NBT/BCIP substrat. Controls were run in parallel and treated with preimmuneserum.

Results

Cystosori of *P. betae* developed in roots two weeks after inoculation of the plants with a zoospore suspension. The development of rhizomania disease was observed on the whole roots using light microscopy (*P. betae* cystosori) and ELISA (BNYVV). Roots of infected plants were used for tissue cross-sections preparation. Consecutive sections were collected from cryotome and processed. Tissue structures were visualized by alcian blue and cystosori by kernechtred. Corresponding consecutive sections were investigated by immunohistology.

P. betae cystosori were found in rhizodermal and cortex cells. BNYVV was visualized using primary anti-BNYVV antibodies and the labelling indicating the presence of BNYVV coat protein was detected irregularly mainly within cortical cells, and in a lesser extend in xylem vessels (Fig. 2).

Infection of sugar beet plants with BNYVV and/or *P. betae* resulted in the synthesis of both the basic β -1,3-gluconase (Glu2) and basic chitinase (Ch4). The enzymes accumulated predominantly in the cell walls and extracellular matrix of endodermis, as well as adjacent cells to endodermis.

Fig. 1 Cross-sections of sugar beet roots of healthy plants.

amjc - cell walls and nuclei stained with alcian blue and kernechtrot; *K* – tissue section probed with BNYVV antibodies, *Glu2* – immunolocalization of basic β -1,3-gluconase class II (Glu2)

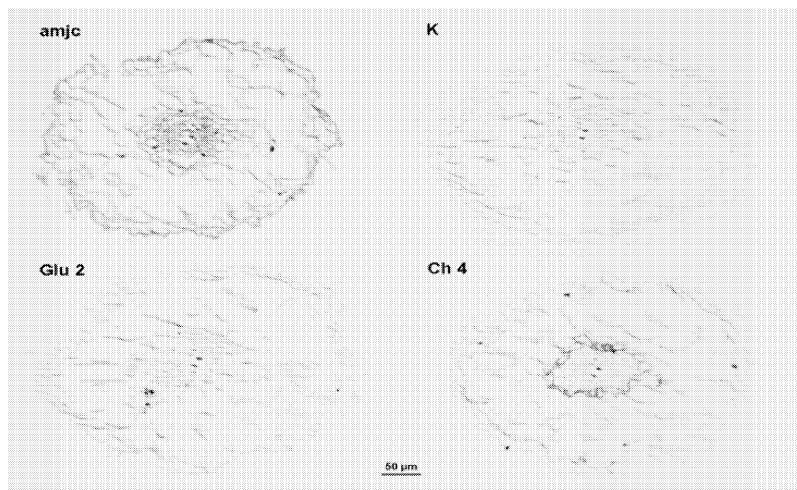

showing that Glu2 is not present in roots constitutively; *Ch 4* - immunolocalization of basic chitinase class IV (Ch4) revealing the constitutive presence of Ch4 in endodermis.

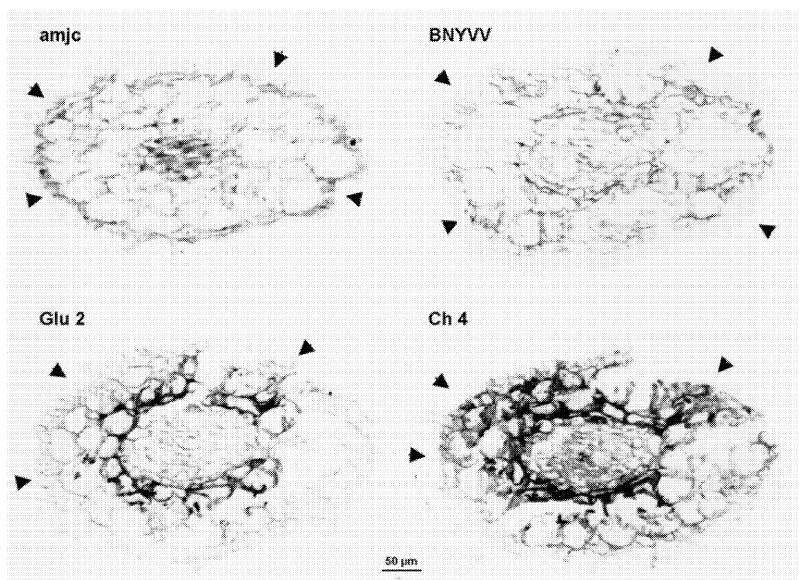

Fig. 2 Consecutive cross-sections of sugar beet root infected with BNYVV. Immunolocalization of BNYVV, basic chitinase class IV (Ch4) and basic β -1,3-glucanase (Glu2) in sugar beet roots infected with BNYVV and *P. betae* on consecutive root tissues cross-sections. *amjc* - cell walls and nuclei stained with alcian blue and kernechtred on root tissue sections. Arrows indicate the presence of cystosori of *P. betae* stained by kernechtred (red colour). *BNYVV* - arrows indicate cystosori of *P. betae* and blue staining the presence of the virus. *BNYVV* is present prevalently close to the cells containing cystosori of *P. betae*. *Glu2* - immunolocalization of basic β -1,3-glucanase class II (Glu2). Arrows indicate cystosori of *P. betae* and the staining the presence of glucanase, which is present mainly in extracellular space of cortex cells. *Ch 4* - immunolocalization of basic chitinase class IV (Ch4). Arrows indicate cystosori of *P. betae*.

Discussion

It has been shown previously (Gottschalk *et al.*, 1998), that Glu2 accumulates in sugar beet leaves infected with fungus *C. beticola*, where high levels of Glu2 were observed in the necrosis and in the vicinity of the necrotic lesions and only low levels of the enzyme were found at distant sites suggesting local and non-systemic fashion of induction. Similarly, immunohistological localization of Ch4 in *C. beticola* infected leaves revealed rather local than systemic induction proximally to the necrotic lesions (Nielsen *et al.*, 1996). Moreover, the connection between cultivar resistance to *C. beticola* and both temporal and spatial distribution of Ch4 was shown, indicating the participation of Ch4 in the resistance mechanisms.

In our studies we demonstrated accumulation of both Glu2 and Ch4 in rhizomania diseased sugar beet roots. Similarly to sugar beet - *C. beticola* interaction in leaves, BNYVV and/or *P. betae* stimulate active defence mechanisms in root tissues resulting in the deposition of basic chitinase Ch4 and basic β -1,3-glucanase Glu2 in cell walls and extracellular spaces. This surprising extracellular localization of these hydrolases was reported previously by Nielsen *et al.* (1996) and Gottschalk *et al.* (1998) in sugar beet leaves infected with *C. beticola* despite the

basic isozymes of PR-proteins are usually located in vacuoles (Boller and Metraux, 1988; Wubben *et al.*, 1992).

Whether Glu2 and Ch4 directly participate in the resistance to rhizomania remains questionable, as the co-location with the vector *P. betae* structures was not confirmed and their role in the suppression BNYVV multiplication is not probable. However, their presence in rhizodermal and cortex cells could interfere with plasmodia formation and the production of secondary zoospores that could slow down the rate of infection process. Further detailed investigations of time-course zoospore production and release can provide more information on the function of these hydrolases in infected roots.

Acknowledgements

We thank Dr. J.D. Mikkelsen and J. Kreiberg from Danisco Ingredience, Copenhagen, Denmark, for providing Glu2 and Ch4 antibodies, and Dr. U. Kastir from the Institute of Resistance Research and Pathogen Diagnostics, Aschersleben, Germany for isolate of *P.betae* wearing BNYVV.

The research was funded by a grant from the Czech Grant Agency no. 522/00/0602.

References

- Boller T, Metraux JP. 1988. Extracellular localization of chitinase in cucumber. *Physiological and Molecular Plant Pathology* 33: 11-16.
- Dubois F, Sangwan RS, Sangwannorreel BS. 1994. Spread of *Beet necrotic yellow vein virus* in infected seedlings and plants of sugar beet (*Beta vulgaris*). *Protoplasma* 179: 72-82.
- Gottschalk TE, Mikkelsen JD, Nielsen JE, Nielsen KK, Brunstedt J. 1998. Immunolocalization and characterization of a *Beta*-1,3-glucanase from sugar beet, deduction of its primary structure and nucleotide sequence by cDNA and genomic cloning. *Plant Science* 132: 153-167.
- Kuc J., 1995. Induced systemic resistance. In: Hammerschmidt R, Kuc J, eds. *Induced resistance to disease in plants*. Dordrecht, The Netherlands: Kluwer, 169-175.
- Nielsen JE, Nielsen KK, Mikkelsen JD. 1996. Immunohistological localization of a basic class IV chitinase in *Beta vulgaris* leaves after infection with *Cercospora beticola*. *Plant Science* 119: 191-202.
- Nielsen KK, Bojsen K, Collinge DB, Mikkelsen JD. 1994. Induced resistance in sugar beet against *Cercospora beticola* – induction by dichloroisonicotinic acid is independent of chitinase and *Beta*-1,3-glucanase transcript accumulation. *Physiological and Molecular Plant Pathology* 45: 89-99.
- Wubben JP, Joosten MHAJ, Vankan JAL, Dewit PJGM. 1992. Subcellular localization of plant chitinases and 1,3-*Beta*-glucanases in *Cladosporium fulvum* (syn. *Fulvia fulva*) infected tomato leaves. *Physiological and Molecular Plant Pathology* 41: 23-32.

THE DEVELOPMENT OF A QUANTITATIVE ELISA FOR THE DETECTION OF *POLYMYXA BETAE*.

Crawford S. Kingsnorth, Effie S. Mutasa-Göttgens, Daph M. Chwarszczynska & Mike J.C. Asher.

Broom's Barn Research Station, Higham, Bury St Edmunds, Suffolk, IP28 6NP, U.K.

Summary

The obligate parasite *Polymyxa betae* infects Chenopodiaceae and in temperate climates does not cause any significant deleterious effects. However, *P. betae* can harbour and transmit *Beet necrotic yellow vein virus* (BNYVV), which causes the sugar beet disease rhizomania. Development of *P. betae* resistant sugar beet cultivars could be used as an effective method of controlling rhizomania, by preventing or reducing the entry of the virus into the plant. To screen for *P. betae* resistant plants, a simple, quick and quantitative diagnostic test is required. cDNA derived from a *P. betae* glutathione-S-transferase (GST) gene was cloned into a bacterial expression vector to produce purified protein antigen. Both polyclonal and monoclonal antibodies have been raised to this and confirmed by Western analysis to be specific to the *Polymyxa* GST protein. The antibodies can detect both the purified recombinant protein and the *P. betae* GST from infected plants, and have been used to develop a quantitative triple antibody sandwich ELISA, which is currently in trial.

Introduction

Polymyxa betae is a soilborne obligate parasite of sugar beet and the vector of *Beet necrotic yellow vein virus* (BNYVV), which causes the disease rhizomania (Asher 1993). Development of resistance to the virus vector should provide protection against the disease, as resistant wild *Beta* species virtually eliminate or greatly reduce virus transmission (Paul *et al.*, 1992). Commercial varieties, based on monogenic resistance to the virus are available and are grown widely throughout continental Europe and the USA (Richard-Molard and Cariolle 2001). Novel strains of the virus could overcome this resistance, but by combining *P. betae* resistance in the same plant this possibility could be reduced. Large-scale screening for *P. betae* resistant plants is currently not feasible because the only tests available for detecting infection are either not quantitative or too laborious. To overcome this we have been developing tests for *P. betae* based both on molecular diagnostic (Mutasa *et al.*, 1993; Mutasa *et al.*, 1995; Mutasa *et al.*, 1996) and serological techniques (Mutasa-Göttgens *et al.*, 1999; Mutasa-Göttgens *et al.*, 2000). Here we describe the development and evaluation of a quantitative triple antibody sandwich ELISA test for *P. betae*.

Materials and Methods

Monoclonal antibody production

The cDNA encoding glutathione-S-transferase (accession number AJ132355) was cloned into the pQE expression system (Qiagen GmbH, Hilden, Germany). Expression and purification of the GST was carried out following the manufacturer's instructions. The purified recombinant protein was used as the antigen for monoclonal antibody production using standard protocols. Five Balb C mice, aged 6-8 weeks old, were immunised 3 times over a 3 month period using 100µg purified GST mixed with an equal volume of Freund's incomplete adjuvant per mouse per injection. Ten days after the third injection, tail bleeds were carried out and ELISA tests performed to identify the mouse with the optimal titre of the required antibody. This mouse was

then given a pre-fusion boost 4 days prior to spleen removal and fusion to SP2/0-Ag14 myeloma cells, which was carried out using standard techniques (Galfre and Milstein 1981). Fusion cell supernatants were tested for the presence of antibodies that recognised GST by indirect ELISA (Voller *et al.*, 1976), using the purified protein as the antigen trap. Bound antibodies were detected using anti-mouse IgG horseradish peroxidase conjugate (Sigma Immuno Chemicals) and 3,3',5,5'-Tetramethylbenzidine as the substrate. Supernatants that gave positive results in the first round of screening were tested further by Western blot analysis to confirm that the antibody specifically bound both purified GST and the native protein. Antibodies were also tested for cross reactivity to the related *P. graminis*, the *Escherichia coli* strain used to generate the recombinant protein and other plant pathogenic fungi found on roots, *Pythium ultimum* and *Aphanomyces cochlioides*. All antibodies were characterised to class and sub class using an isostrip mouse monoclonal antibody isotyping kit (Roche Biochemicals, UK).

ELISA conditions

Plants grown in naturally infested soil were sampled by washing in water to remove soil. The root material was then isolated, blotted dry and placed in extraction bags (Bioreba AG, Reinach, Switzerland). Extraction buffer (2% w/v polyvinylpyrrolidone (PVP) 10,000 in PBS) was added and the roots were homogenised using a Homex 6 plant tissue homogenizer (Bioreba). The resultant plant sap solution was removed from the bag and used directly in the ELISA tests. For routine ELISA work plates were washed with PBSt using an EL 404 microtitre autowasher (Bio-Tek instruments, Wacooski, USA). All reaction volumes were 100µl and incubations were at room temperature for a minimum of one hour. The anti-GST monoclonal antibody was adsorbed onto a Nunc-Immuno™ MaxiSorb™ coated 96 well microtitre plate, using carbonate coating buffer (15mM Na₂CO₃, 35mM NaHCO₃ pH 9.6) and either incubated for one hour at room temperature or left overnight at 4°C prior to washing. The plant sap or purified protein control was then added, incubated then washed, followed by the secondary antibody, which was also incubated and washed. Alkaline phosphatase conjugated anti-rabbit antibody was then added, incubated then washed. Finally, the substrate (one Sigma 104® phosphatase substrate

tablet (Sigma, Dorset, UK) in 10ml substrate buffer (0.86M diethanolamine, 0.14M diethanolamine-HCl, 1mM MgCl₂ pH 9.8)) was added and incubated for one hour. The intensity of the colour reaction was measured using an Emax Precision Microplate Reader (Molecular Devices, Wokingham, U.K.) at 405nm.

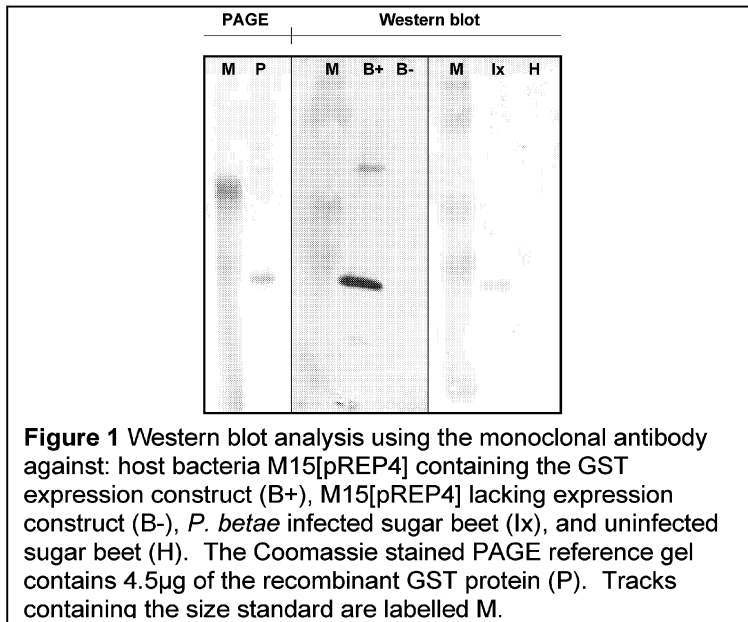

Results and Discussion

Initial attempts to develop a plate bound antibody ELISA assay to detect GST worked well with the purified protein, but when used with extracted plant sap the test could not distinguish between *P. betae* infected and uninfected material. Triple antibody sandwich ELISA could overcome the problems associated with the plate trap technique, but required another specific antibody. The GST cDNA from Mutasa-Göttgens *et al.* (2000) was cloned into the pQE vector system to allow expression and purification of the GST, and DNA sequence analysis was used to confirm that the cDNA had been correctly cloned into the expression vector. The protein was purified, expressed and dialysed against PBS. The dialysed protein was used as the antigen to produce a specific monoclonal antibody of isotype IgG2a, which recognised the recombinant and native GST protein (Fig 1).

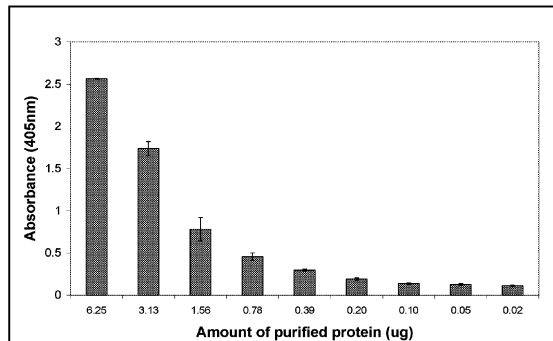

Figure 2 Triple antibody ELISA of purified GST.

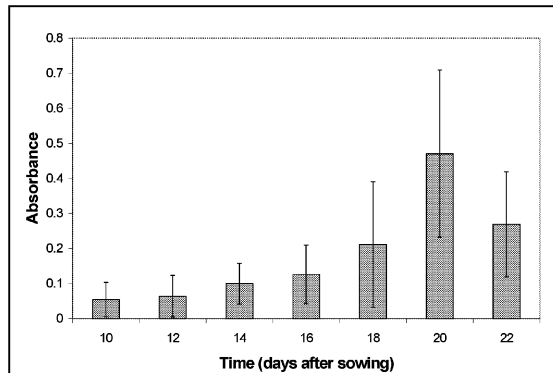

Figure 3 Time course ELISA to determine levels of *P. betae* GST in sugar beet roots grown in naturally infested soil. Absorbance values are the average of ten plants minus the background absorbance obtained from uninfected plants.

By combining the monoclonal antibody with the *Polymyxa* specific polyclonal antibody developed by Mutasa-Göttgens *et al.* (2000) a triple antibody sandwich was developed, using the purified GST protein as the target. Optimum conditions for this ELISA required the monoclonal antibody to be bound to the plate as the capture antibody, and the polyclonal antibody as the secondary antibody. The test worked well with the purified protein (Fig 2), but this was also true of the plate-trapped antigen ELISA.

To adapt the ELISA for plant root sap, a number of variables needed to be optimised. These included the culturing and sampling of infected and uninfected plants, optimisation of the extraction buffer and the best mechanical method of sap extraction. PVP was the best sample extraction buffer, and is the same extraction buffer used in the BNYVV ELISA. This allows both vector and virus to be measured in the same sample.

The test is currently in trial using plants grown in naturally infested soil in a CE room and results obtained so far indicate that it is able to discriminate reliably between infected and uninfected plants. The test has also been used to monitor the accumulation of *P. betae* infection in time-course experiments (Fig 3). It is expected that this test will be useful for routine screening in our breeding programme, to identify plants with *P. betae* resistance.

Acknowledgements

We would like to thank Gary Keane, HRI Wellesbourne, for the production of the monoclonal antibody and acknowledge funding British Beet Research Organisation. Broom's Barn Research Station is grant aided from the Biotechnology and Biological Sciences Research Council.

References

- Asher, M. J. C. (1993) Rhizomania. In *The Sugar Beet Crop: Science into Practice* (D. A. Cooke and R. K. Scott, eds). London: Chapman and Hall, pp.311-246.
- Galfre, G. and Milstein, C. (1981) Preparation of monoclonal antibodies: strategies and procedures. *Methods in Enzymology* 73, 3-46.
- Mutasa, E. S., Ward, E., Adams, M. J., Collier, C. R., Chwarszczynska, D. M. and Asher, M. J. C. (1993) A sensitive DNA probe for the detection of *Polymyxa betae* in sugar beet roots. *Physiological and Molecular Plant Pathology* 43, 379-390.
- Mutasa, E. S., Chwarszczynska, D. M., Adams, M. J., Ward, E. and Asher, M. J. C. (1995) Development of PCR for the detection of *Polymyxa betae* in sugar beet roots and its application in field studies. *Physiological and Molecular Plant Pathology* 47, 303-313.
- Mutasa, E. S., Chwarszczynska, D. M. and Asher, M. J. C. (1996) Single tube, nested PCR for the diagnosis of *Polymyxa betae* infection in sugar beet roots and colorimetric analysis of amplified products. *Phytopathology* 86, 493-497.
- Mutasa-Göttgens, E. S., Chwarszczynska, D. M., Kingsnorth, C. S., Halsey, K. and Asher, M. J. C. (1999) The development of a recombinant antibody to *Polymyxa betae* and its use in resistance screening. *The Fourth Symposium of the International Working Group on Plant Viruses with Fungal Vectors*. Monterey, California. pp. 97-100
- Mutasa-Göttgens, E. S., Chwarszczynska, D., Halsey, K. and Asher, M. J. C. (2000) Specific polyclonal antibodies for the obligate plant parasite *Polymyxa* - a targeted recombinant DNA approach. *Plant Pathology* 49, 276-287.
- Paul, H., Henken, B., Debock, T. S. M. and Lange, W. (1992) Resistance to *Polymyxa betae* in *Beta* species of the section *Procumbentes*, in hybrids with *Beta vulgaris* and in monosomic chromosome additions of *Beta procumbens* in *Beta vulgaris*. *Plant Breeding-Zeitschrift Fur Pflanzenzuchtung* 109, 265-273.
- Richard-Molard, M. and Cariolle, M. (2001) Water and abiotic stress and genetic improvement. 64th Congress of the International Institute for Beet Research pp. 153-158
- Voller, A., Bidwell, D. and Bartlett, A. (1976) Microplate enzyme immunoassays for the immunodiagnosics of virus infections. *American Society for Microbiology*.

STUDY OF HOST RANGE OF THE *BET* SOILBORNE POMOVIRUS

P. Kudlackova and P. Rysanek

Department of Plant Protection, Czech University of Agriculture, 165 21 Prague, Czech Republic, e-mail: Kudlackova@af.czu.cz.

Host range of *Beet soilborne pomovirus* (BSBV) was studied using baiting plants and soil from two fields known to be contaminated by BSBV. BSBV was detected by ELISA and PCR. Twenty-one species mainly from the *Chenopodiaceae* and *Amaranthaceae* families were tested, but presence of BSBV was proved in *Beta vulgaris* (ssp. *vulgaris*, *maritima*, *macrocarpa*, sugar beet (15 varieties), fodder beet (3 varieties), red beet (3 varieties), mangold (3 varieties)) and in *Spinacia oleracea* (15 varieties) only. Other species didn't contain BSBV (*Chenopodium album*, *C. amaranticolor*, *C. bonus-henricus*, *C. ficifolium*, *C. foetidum*, *C. hybridum*, *C. murale*, *C. polyspermum*, *C. quinoa*, *C. ugandae*, *Atriplex lampa*, *A. calotheca*, *Celosia argentea*, *C. cristata*, *Amaranthus lividus*, *A. retroflexus*, *A. tricolor*, *Beta patellaris*, *Tetragonia expansa*). So, the host range of BSBV seems to be rather restricted.

Introduction

BSBV was first found by Ivanovic and Mcfarlane (1982) in England and better described by Henry et al. (1986). It may cause symptoms resembling rhizomania caused by *Beet necrotic yellow vein benyvirus* (BNYVV) on sugar beet but it also frequently occurs in symptomless plants (Prillwitz and Schlosser, 1992). It is very widespread in sugar beet growing areas all around the world (Prillwitz and Schlosser, 1992, Lindsten, 1991, Turina et al., 1996) and is also present in the Czech Republic (Rysanek and Kudlackova, 2000). Particles of BSBV have several modal lengths (65, 150 and 300 nm) and about 20 nm in diameter. The virus is transmitted by soil protist *Polymyxa betae* (Ivanovic et al., 1983) and fulfils criteria to be included into genus *Pomovirus* (Hull, 2002). There are no data about the losses of infected plants under field conditions but after mechanical infection of roots it caused 20 % decreasing of root weight of young plants (Kaufmann et al., 1993). In pot trials the weight of plants after inoculation by viruliferous zoospores of *P. betae* was decreased even by 40 % (Prillwitz and Schlosser, 1992). Host range of BSBV was studied by Henry et al. (1986) using mechanical inoculation of leaves of tested plants. Little is known about BSBV host range if it is transmitted in natural way by *P. betae* zoospores.

Materials and Methods

BSBV host range was studied using baiting plants of tested species sown directly into contaminated soil in a climatized room at 22 °C. Soils from two localities (Prerov nad Labem and Rostoklaty, Central Bohemia) were used. *Beta patellaris*, *Beta vulgaris* (ssp. *vulgaris*, *maritima*, *macrocarpa*, sugar beet (15 varieties, including rhizomania resistant), fodder beet (3 varieties), red beet (3 varieties), mangold (3 varieties), *Spinacia oleracea* (15 varieties), *Chenopodium album*, *C. amaranticolor*, *C. bonus-henricus*, *C. ficifolium*, *C. foetidum*, *C. hybridum*, *C. murale*, *C. polyspermum*, *C. quinoa*, *C. ugandae*, *Atriplex lampa*, *A. calotheca*, *Celosia argentea*, *C. cristata*, *Amaranthus lividus*, *A. retroflexus*, *A. tricolor*, and *Tetragonia expansa* were tested. After six weeks plants were harvested, their roots were washed and tested by ELISA using polyclonal antibodies from Prof. Lindsten. Results of ELISA were confirmed by multiplex PCR enabling discrimination of BSBV and *Beet virus Q* as described by

Zouhar and Rysanek (2000). At least 10 plants of each species were tested and all (including plant sowing) was repeated three times.

Results

Presence of BSBV was proved both by ELISA and PCR in *Beta vulgaris* (ssp. *vulgaris*, *maritima*, *macrocarpa*, and all varieties of sugar beet, fodder beet, red beet, mangold) and *Spinacia oleracea* only. All other species (*Chenopodium album*, *C. amaranticolor*, *C. bonus-henicus*, *C. ficifolium*, *C. foetidum*, *C. hybridum*, *C. murale*, *C. polyspermum*, *C. quinoa*, *C. ugandae*, *Atriplex lampa*, *A. calotheca*, *Celosia argentea*, *C. cristata*, *Amaranthus lividus*, *A. retroflexus*, *A. tricolor*, *Beta patellaris* and *Tetragonia expansa*) never contained the virus. The results were the same for both soils.

Discussion

Our results show that the BSBV host range is rather restricted if natural mode of transmission by *P. betae* zoospores is used. So, only some plant species as *Beta vulgaris*, *B. macrocarpa* and *Spinacia oleracea* can be infected both mechanically on leaves and by means of *P. betae* zoospores on roots whereas other species described as BSBV hosts by Henry et al. (1986), e.g. *Chenopodium album*, *C. amaranticolor*, *C. foetidum*, *C. murale*, *C. polyspermum* and *C. quinoa* can be infected by mechanical inoculation on leaves but not by *P. betae* zoospores on roots. In some cases (*Tetragonia expansa*, *Beta patellaris*) the absence of BSBV in roots may be attributed to the absence of *P. betae* infection but in others roots are infected by *P. betae* without BSBV presence. It may be due either by root immunity to virus infection or by its non-transmissibility by concrete *forma speciales* of *P. betae* infecting this plant species as in the case of BNYVV (Hugo et al., 1996). So, in the field BSBV perpetuates probably on cultivated species of beet and spinach only.

References

- Henry C. M., Jones R. A., and Coutts R. H. A. (1986). Occurrence of a soil-borne virus of sugar beet in England. *Plant Pathol.* 35, 585-591.
- Hugo S.A., Henry C., and Harju V. (1996). The role of alternative hosts of *Polymyxa betae* in transmission of *Beet necrotic yellow vein virus* (BNYVV) in England. *Plant Pathol.* 45, 662-666.
- Hull R. (2002). *Plant Virology*. Academic Press, San Diego, 1001 pp.
- Ivanovic M., and Macfarlane I. (1982). A tubular virus associated with infection of sugar beet by *Polymyxa betae*. *Rothamsted Exp. Stn. Rep.* 1981, 190-191.
- Ivanovic M., Macfarlane I., and Woods R. D. (1983). Viruses of sugar beet associated with *Polymyxa betae*. *Rothamsted Exp. Stn. Rep.* 1982, 189-190.
- Kaufmann A., Koenig R., and Rohloff H. (1993). Influence of *Beet soilborne virus* on mechanically infected sugar beet. *Plant Pathol.* 42, 413-417.
- Lesemann D. -E., Koenig R., Lindsten K., and Henry C. M. (1989). Serotypes of beet soilborne furovirus from FRG and Sweden. *Bulletin EPPO* 19, 539-540.
- Lindsten K. (1991). Report on *P. betae* – transmitted beet viruses in Sweden. *Beet necrotic yellow vein workshop*, Colmar, 39-42.
- Prillwitz H., and Schlosser E. (1992). *Beet soilborne virus*: occurrence, symptoms and effect on plant development. *Med. Fac. Landbouww. Univ. Gent* 57/2a, 295-302.
- Putz C., and Vuittenez A. (1980). The intracellular location of *Beet necrotic yellow vein virus*. *J. Gen. Virol.* 50, 201-204.

- Rysanek P., and Kudlackova P. (2000). Distribution of soilborne viruses infecting sugar beet in the Czech Republic. *Book of abstracts 5th Congr. EFPP*, Giardini Naxos, p. 53.
- Turina M., Resca R., and Rubies-Autonell C. (1996). Survey of soil-borne virus diseases in Italy. *Proc. 3rd Symp. IWGPVFFV*, Dundee, 185-188.
- Zouhar M., and Rysanek P. (2000). Detection and differentiation of *Beet soilborne virus* and *Beet virus Q* by PCR. *Book of abstracts 5th Congr. EFPP*, Giardini Naxos, p. 54.

ELECTRONMICROSCOPIC STUDY OF BEET SOILBORNE POMOVIRUS

Pavla Kudlackova, Miloslav Zouhar and Pavel Rysanek

Department of Plant Protection, Czech University of Agriculture, 165 21 Prague, Czech Republic, e-mail kudlackova@af.czu.cz.

Summary

Beet soilborne pomovirus (BSBV) was observed both in the sap and in tissues from local lesions on *Chenopodium quinoa* leaves after their embedding into acrylic resin LR White. It has rod-like particles of various lengths. Immunocapturing with polyclonal antibodies was used to enhance number of particles on grids and immunolabelling by colloidal gold was used for better visibility of virus particles in tissues. BSBV forms inclusions of several particles adhering side to side each to another but its relatively low concentration in tissues makes its observation rather difficult.

Introduction

BSBV was first found by Ivanovic and Mcfarlane (1982) in England and better described by Henry et al. (1986). It may cause symptoms resembling rhizomania caused by *Beet necrotic yellow vein benyvirus* (BNYVV) on sugar beet but frequently it also occurs in symptomless plants (Prillwitz and Schlosser, 1992). It is very widespread in sugar beet growing areas all around the world (Prillwitz and Schlosser, 1992, Lindsten, 1991, Turina et al., 1996) and is present also in the Czech Republic (Rysanek and Kudlackova, 2000). Particles of BSBV have several modal lengths (65, 150 and 300 nm) and about 20 nm in diameter. The virus is transmitted by soil protist *Polymyxa betae* (Ivanovic et al., 1983) and fulfils criteria to be included into genus *Pomovirus* (Hull, 2002). There are no data about the losses of infected plants under field conditions but after mechanical infection of roots it caused 20 % decreasing of root weight of young plants (Kaufmann et al., 1993). In pot trials the weight of plants after inoculation by viruliferous zoospores of *P. betae* was decreased even by 40 % (Prillwitz and Schlosser, 1992). Morphology of BSBV particles has already been studied by Henry et al. (1986) and by Lesemann et al. (1989) but little is still known about BSBV appearance in tissues of infected plants.

Materials and Methods

BSBV was mechanically inoculated onto *Chenopodium quinoa* leaves from roots of sugar beet baiting plants growing in contaminated soil from Rostoklaty (Central Bohemia). Local lesions (5 to 8 days post inoculation) or roots of baiting plants were cut into small pieces 2x1 mm which were fixed 2 h in 2 % glutaraldehyde at 4 °C, washed in phosphate buffer, postfixed 2 h in 1 % osmium tetroxide and again washed in re-distilled water. Then the tissue was dehydrated in a graded ethanol series (30, 50, 70, 90 %, 30 min each and 100 % overnight), infiltrated by LR White resin (1:3, 1:1, 3:1 mixture with ethanol, 1 h each and 100 % resin 2x1 h) and embedded in resin in gelatine capsules with polymerization at 60 °C for 2 days. Ultrathin sections were cut with LKB Ultratome III and put onto nickel grids covered with pioloform membrane. Immunolabelling was done placing the grids onto drops of chemicals: water 5 min, saturated solution of NaIO₄ 15 min, water 3x2 min, 0,1 M HCl 10 min, water 2x2 min, PBS with 1 % BSA and 0,1 % Tween 15 min, antibodies to BSBV (prof. Lindsten) in PBS – BSA 1:50 1 h at 37 °C, washing in PBS 10 min and 5x2 min, antirabbit IgG coupled to colloidal gold 15 nm (Biocell) 1:20 in PBS-BSA 1 h at 37 °C, washing in PBS as above, washing in water 2x5 min, 2

% uranylacetate 5 min, washing in water 10x1min, lead citrate 5 min, washing in water 10x1 min. For ISEM grids were incubated in antibodies in PBS (1:800) 1 h at 37 °C, briefly washed with PBS, leaf homogenate (1:10 in PBS-BSA, spun for 10 min at 10000 g) 1 h at 37 °C, washing with PBS and water, 2 % uranylacetate 5 min, brief washing in water. Observation of grids was done with Tesla BS 500 electron microscope.

Results

BSBV was observed both in sap and in tissues from local lesions on *Chenopodium quinoa* leaves. In sap both single particles and aggregates of several particles were seen. The particles were decorated to some extent with antibodies (Fig. 1). In tissues from local lesions inclusions of virus particles were also seen with gold labelling. The inclusion consisted usually from only small number of particles adhering side to side each to another (Fig. 2). They occurred either isolated or groups of them were scattered in the cytoplasm of parenchyma cells. Because of small concentration of virus in tissues it was rather difficult to find it even using immunolabelling. Till now the virus has not been observed in roots of sugar beet.

Discussion

This is the first report of observation of BSBV directly in tissues of infected plants. The inclusions of BSBV are quite different from those of BNYVV in the shape of fish skeleton (Putz and Vuittenez, 1980) with which BSBV frequently occurs in mixed infections. Comparing to BNYVV, the concentration of BSBV in tissues was very small as already mentioned by Henry et al. (1986) and confirmed by our work testing PCR (Zouhar and Rysanek, 2000). That is why immunolabelling was very useful during the work as it enabled to find virus inclusions in the cytoplasm of infected cells but the antibodies had to be rather concentrated (1:50) for this purpose. In this case danger of background exists but with some exceptions we did not have this problem. BSBV particles from sap were of different length as already described by Ivanovic et al. (1983) and Lesemann et al. (1989) but we have not measured them. The particles were slightly decorated by antibodies. Without ISEM it was almost impossible to find the virus.

Fig. 1 BSBV from sap from local lesions on *Chenopodium quinoa* leaves adsorbed onto grids coated with BSBV antiserum diluted 1: 800. Magnification 500,000 x.

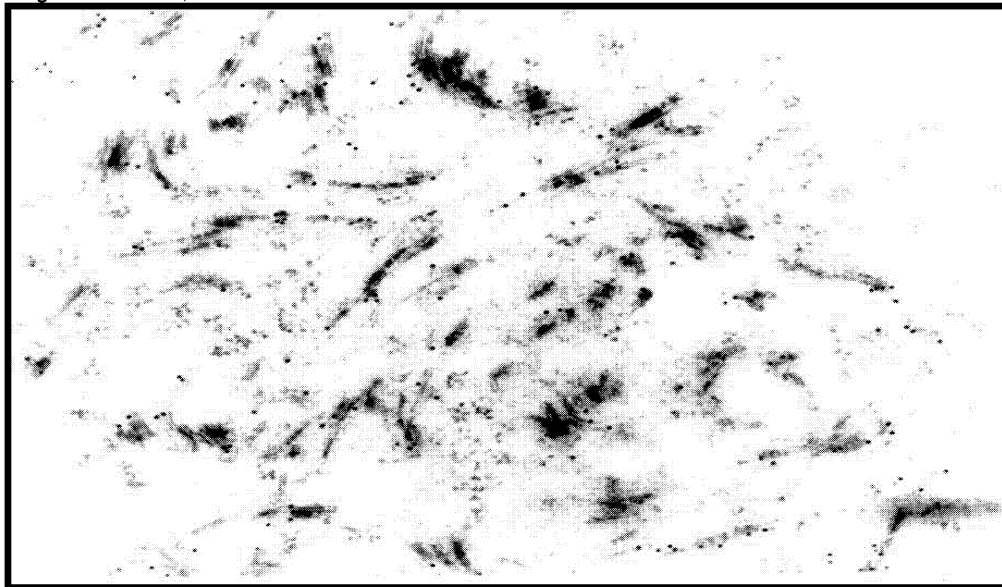
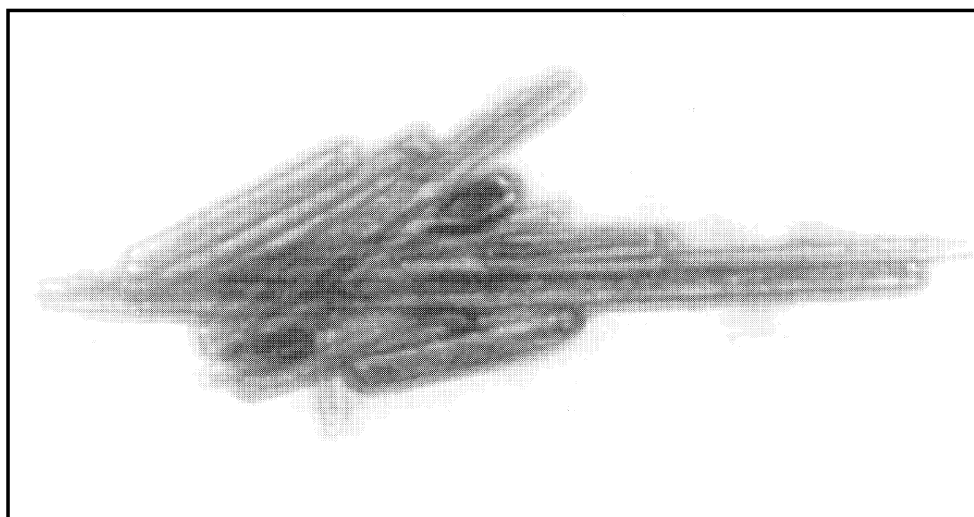

Fig. 2 BSBV in cytoplasm in local lesions from infected leaf of *Chenopodium quinoa* labelled with colloidal gold (15 nm). Bar represents 100 nm.



References

- Henry C. M., Jones R. A., and Coutts R. H. A. (1986). Occurrence of a soil-borne virus of sugar beet in England. *Plant Pathol.* 35, 585-591.
- Hull R., (2002). *Plant Virology*. Academic Press, San Diego, 1001 pp.
- Ivanovic M., and Macfarlane I., (1982). A tubular virus associated with infection of sugar beet by *Polymyxa betae*. *Rothamsted Exp. Stn. Rep.* 1981, 190-191.
- Ivanovic M., Macfarlane I., and Woods R. D. (1983). Viruses of sugar beet associated with *Polymyxa betae*. *Rothamsted Exp. Stn. Rep.* 1982, 189-190.
- Kaufmann A., Koenig R., and Rohloff H. (1993). Influence of *Beet soilborne virus* on mechanically infected sugar beet. *Plant Pathol.* 42, 413-417.
- Lesemann D. -E., Koenig R., Lindsten K., and Henry C. M. (1989). Serotypes of beet soilborne furovirus from FRG and Sweden. *Bulletin EPPO* 19, 539-540.
- Lindsten K. (1991). Report on *P. betae* – transmitted beet viruses in Sweden. *Beet necrotic yellow vein workshop*, Colmar, 39-42.
- Prillwitz H., and Schlosser E. (1992). *Beet soilborne virus*: occurrence, symptoms and effect on plant development. *Med. Fac. Landbouww. Univ. Gent* 57/2a, 295-302.
- Putz C., and Vuittenez A. (1980). The intracellular location of *Beet necrotic yellow vein virus*. *J. Gen. Virol.* 50, 201-204.
- Rysanek P., and Kudlackova P. (2000). Distribution of soilborne viruses infecting sugar beet in the Czech Republic. *Book of abstracts 5th Congr. EFPP*, Giardini Naxos, p. 53.
- Turina M., Resca R., and Rubies-Autonell C. (1996). Survey of soil-borne virus diseases in Italy. *Proc. 3rd Symp. IWGPV/FV*, Dundee, 185-188.

PARTIAL CHARACTERIZATION OF AN UNNAMED SOILBORNE SUGAR BEET VIRUS IN THE UNITED STATES

Hsing-Yeh Liu, J. L. Sears, and R. T. Lewellen

USDA-ARS, 1636 East Alisal Street, Saunas, California 93905, USA

Summary

In rhizomania infested fields, sugar beet leaves with oak-leaf pattern Symptoms different from rhizomania were found in California. A virus with rigid rod-shaped particles was isolated. For purposes of discussion this unknown virus was designated Beet oat-leaf virus (BOLV). BOLV is serologically distinct from *Beet necrotic yellow vein virus* (BNYVV), *Beet soil-borne mosaic virus* (BSBMV), and *Beet soil-borne virus* (BSBV). The host range of BOLV is similar to BNYVV and BSBMV mostly infecting *Chenopodiaceae* plants. BOLV produces chlorotic local lesions with a necrotic ring after mechanical inoculations. Particles were about 20 nm wide and ranged from 80 to 640 nm with three modal lengths: 180-200 nm, 260-280 nm, and 300-320 nm. *Polymyxa betae* transmission of BOLV was demonstrated through a bioassay by using BOLV-infected cystosori and sugar beet as bait. BOLV has been purified from *Spinacia oleracea*. The molecular mass of the capsid protein was estimated to be 48.0 kDa. A polyclonal antibody from rabbits has been produced and can be used in ELISA, western blot, and immunogold labelling tests. BOLV appears to be wide spread in U.S. It has been found also in Colorado, Michigan, Minnesota, Nebraska, and Wyoming. BOLV was found in sugar beet alone or co-infected with BNYVV and/or BSBMV. The economic significance of BOLV and its interaction with other furoviruses are not known.

Introduction

During the survey for rhizomania disease, an unnamed virus showed oak-leaf pattern Symptoms on sugar beet (Fig. 1) was found in California. A virus with rod-shaped particles was isolated in addition to *Beet necrotic yellow vein virus* (BNYW), the causal agent of rhizomania. This unnamed virus of sugar beet is tentatively called Beet oak leaf virus (BOLV). BOLV and BNYW serologically are distinct. Taproots of beets infected with BOLV often appear healthy, unlike those of beets infected with BNYW. The objectives of this study are to determine some of the physical, biological, and serological characteristics of BOLV.

Materials and Methods

Symptomatic field sugar beet leaves were ground in 0.1 M phosphate buffer, pH 7.0, and mechanically inoculated to *Chenopodium quinoa* Willd. Each single local lesion was sub-inoculated to *C. quinoa*. The local lesions were freeze dried for virus source. In host range tests, the selected host plant species were mechanically inoculated as above.

BOLV was purified from *Spinacia oleracea*. Infected spinach plants were homogenized with two volumes of 0.1 M phosphate buffer and clarified with 1/2 volume of carbon tetrachloride. Virions were precipitated with 6% polyethylene glycol (mol. wt 6,000) and 0.2 M sodium chloride. The virions were further purified and concentrated by two cycles of differential centrifugation, followed by centrifugation through a 10-35 % sucrose density gradient. Purified virus particles were analyzed by SDS-PAGE for its coat protein.

Antiserum to the purified virions was prepared in New Zealand white rabbits. Freund's complete adjuvant and 500 ug of virus were used for the first injection and incomplete adjuvant with 250 ug of virus was used in four subsequent injections. The double antibody

sandwich (DAS)-ELISA, Western blot procedure, and immunoelectron microscopy technique were conducted essentially as described in the literatures (Clark and Adams, 1977, Towbin, et al, and Lin, 1984).

BOLV infested soil or BOLV infected *Polymyxa betae* cystosori in sugar beet roots were air-dried for 3 weeks to provide inocula for transmission tests. The air-dried roots were ground to a fine powder and mixed with pasteurized potting soil. Sugar beet seeds were added to the pots and covered with pasteurized sand. The pots were kept in insect-proof greenhouse and temperature controlled at about 80 F for 50 to 60 days. Plants were then harvested, tested for BOLV using DAS-ELISA and microscopic examination for *P. betae*.



Fig. 1. Beet *vulgaris* infected with Beet oak-leaf virus showing oak-leaf pattern symptoms.

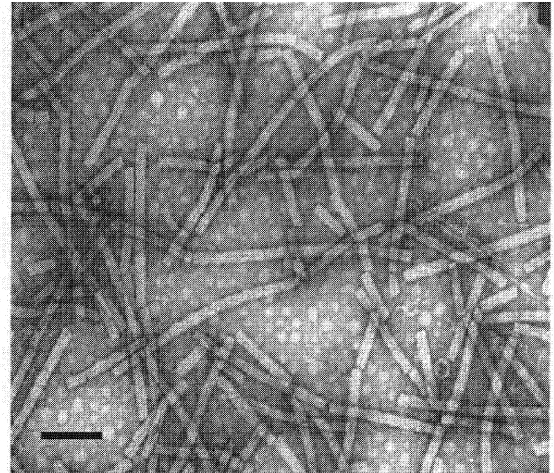

Fig. 2. Purified Beet oak-leaf virus particles are straight, rod-shaped with a central canal. The bar represents 100 nm.

Results

In host range tests, 15 species of 5 families were mechanically inoculated. *C. amaranticolor*, *C. murale*, and *C. quinoa* showed local lesions and *Beta macrocarpa*, *B. vulgaris*, *Spinacia oleracea*, and *Nicotiana benthamiana* produced systemic infection.

In both soil testing and *P. betae* transmission tests sugar beet roots were positive for BOLV in ELISA tests and *P. betae* was found in the infected roots under light microscope. BOLV was recovered by mechanical inoculation to *C. quinoa* plants.

Purified virions were rigid rod-shaped particles with a central canal (Fig. 2). More than 350 virus particles were measured in the leaf dip preparations (Liu, et al, 2000). The virus particles were about 20 nm wide and of three predominant lengths, 180-200 nm, 260-280 nm, and 300-320 nm (Fig.3). The virus particles were capsided by single protein subunits of 48.0 kDa (Fig. 4). The antisera to BOLV produced from purified virions were specific to BOLV in DAS-ELISA and western blot analyses. BOLV-infected plants were successfully identified by immunogold labeling in leaf dips (Fig. 5).

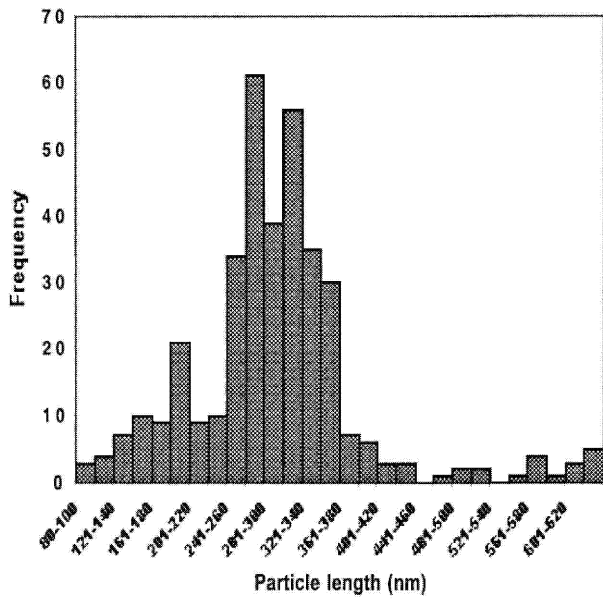

Fig. 3. Particle length distribution of beet oak-leaf virus in leaf dip preparations

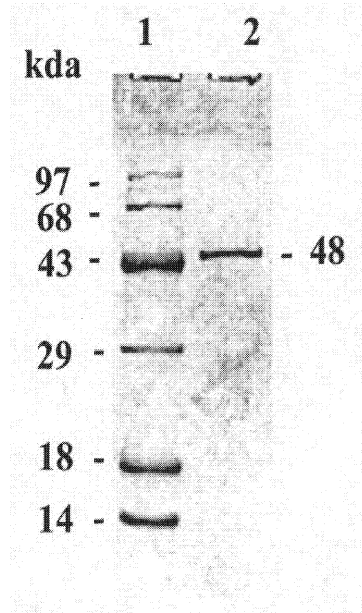

Fig. 4. Sodium dodecyl sulfate-polyacrylamide (12% acrylamide) slab gel showing virion capsid protein. Lane 1, molecular weight standards in order of decreasing mass: phosphorylase B, bovine serum albumin, ovalbumin, carbonic anhydrase, B-lactoglobulin, and lysozyme. Lane 2, Beet oak leaf virus.

Discussion

BOLV was isolated from sugar beet leaves with oak-leaf pattern symptoms from a rhizomania field in California. Like BNYVV, it causes local lesions on *C. quinoa*, but those of BOLV always had a necrotic ring surrounding the chlorotic local lesions. In the later stages, all lesions became large irregular shaped necrotic lesions. Systemic infections of *C. quinoa* were not observed. BOLV was difficult to purify, probably because it is unstable in vitro, tends to aggregate during purification, and/or occurs within plants in low concentration; nevertheless, an antiserum was obtained with partially purified virus preparations. BOLV antiserum was specific and can be used in ELISA tests, Western blots, and immunoelectron microscopy.

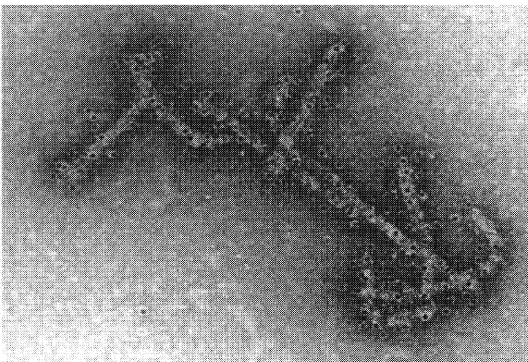

Fig. 5. Immunoelectron microscopy. BOLV-anti-BOLV followed by gold-IgG complexes, showing a direct association of virus particles and labelled gold-IgG complexes.

BOLV seems to be a multiparticulate virus, made up of 3 particles. The molecular weight of BOLV RNAs has not yet been determined. Whether BOLV belongs to benyvirus or other fungal-transmitted rod-shaped viruses will require additional testing.

References

- Clark, M. F., and Adams, A. N. (1977). Characteristics of the microplate method of enzyme-linked immunosorbent assay for the detection of plant viruses. *J. Gen. Virol.* 34, 475-483.
- Koenig, R., Pleij C. W. A., Beier, C., and Commandeur U. (1998). Genome properties of *Beet virus Q*, a new furo-like virus from sugarbeet, determined from unpurified virus. *J. Gen. Virol.* 79, 2027-2036.
- Lin, N.-S. (1984). Gold-IgG complexes improve the detection and identification of viruses in leaf dip preparations. *J. Virol. Methods* 8, 181-190.
- Liu, H.-Y., Wisler, G. C., and Duffus, J. E. (2000). Particle length of whitefly-transmitted criniviruses. *Plant Dis.* 84, 808-805.
- Towbin, H., Staehelin, T., and Gordon, J. (1979). Electrophoretic transfer of proteins from polyacrylamide gels to nitrocellulose sheets: Procedure and some applications. *Proc. Natl. Acad. Sci. USA* 76, 4350-4354.
- Wisler, G. C., Liu, H.-Y., and Duffus, J. E. (1994). *Beet necrotic yellow vein virus* and its relationship to eight sugar beet furo-like viruses from the United States. *Plant Dis.* 78, 995-1001

DEVELOPMENT OF A DIRECT DETECTION METHOD FOR *POLYMYXA* SPP. IN SOIL

L. Ward¹, M. Fenn² & C.M. Henry¹

¹Central Science Laboratory, Sand Hutton, York, U.K. YO41 1LZ, ²School of Plant Sciences, Department of Horticulture and Landscape, Plant Science Laboratories, University of Reading, Whiteknights, Reading. RG6 6AS.

Summary

Polymyxa spp. are important vectors for a number of economically important soil-borne viral diseases. The development of a technique to directly detect virus and vectors in soil could improve assessment of disease risk on farmland prior to cropping. This may enable preventative control measures to be targeted in a more effective way. A rapid method was developed to extract and quantify *Polymyxa* DNA from soils. DNA was extracted from three *Polymyxa betae* and three *Polymyxa graminis* infected soils using an EDTA lysis buffer in combination with a MagneSil™ DNA extraction kit and Kingfisher mL™ magnetic particle processor. DNA yields and purity were determined for each soil by spectrophotometer absorbance readings. Species specific primers designed to sequences within the Internal Transcribed Spacer (ITS) regions enabled recovery and amplification of *P. betae* and *P. graminis* DNA using real-time PCR and TaqMan® chemistry. For the *P. graminis* infected soils, the purity of DNA obtained was sufficient to allow *Polymyxa* DNA to be amplified without dilution to remove inhibitors, but with *P. betae* soils, amplification was only achieved if the DNA was diluted 1:10. A method was developed to quantify *Polymyxa* inoculum in soil. Using TaqMan® PCR, a standard curve was constructed from uninfected soil spiked with known numbers of *P. betae* cystosori. The quantity of *P. betae* inoculum in the three original soils was extrapolated from the curve. Direct detection of *Polymyxa* spp. in soil has not been reported previously. This study has demonstrated a sensitive method of extracting, detecting and quantifying *Polymyxa* spp. DNA in soil.

Introduction

Viruses vectored by *Polymyxa* spp. include *Soil-borne wheat mosaic virus* (SBWMV), *Barley yellow mosaic virus* (BaYMV) and *Beet necrotic yellow vein virus* (BNYVV). These viral diseases are economically significant because infection can result in crop spoilage and yield reduction; also, agronomic choice is limited by the necessity to grow resistant varieties for disease control. The development of a technique to directly detect virus and vectors in soil could improve assessment of disease risk on farmland prior to cropping. This may enable preventative control measures to be targeted in a more effective way.

Methods

Three *P. betae* infected soils were collected from sugar beet fields in Norfolk (Thetford) (Marsham) and Suffolk (Blaxhall). Three *P. graminis* infected soils were collected from cereal fields in Wiltshire (Trowbridge), Lincolnshire (Rothwell) and North Yorkshire (Stamford bridge). The soils were air-dried and sieved (1mm). Three extraction buffers were compared for their efficiency to extract total DNA from the six soils in combination with a Promega MagneSil™ DNA purification kit and a Kingfisher™ magnetic particle processor. The following three extraction buffers were prepared: (i) *EDTA based CTAB buffer* (2% hexadecyltrimethyl ammonium bromide (CTAB), 100mM Tris-HCl pH 8.0, 20mM EDTA, 1.4M NaCl, 20mM mercaptoethanol, 2% PVP-40, 1% Na sulphite (Lohdi *et al.*, 1994); (ii) *Phosphate based CTAB buffer* (2% CTAB, 1.5 NaCl, 120mM Na₂HPO₄, 20mM mercaptoethanol, pH 8.0), (Bell *et al.*, 1999); (iii) *EDTA based lysis*

buffer (50mM Tris-HCl, pH 7.2, 50mM EDTA, 3% SDS, 1% mercaptoethanol (Lee and Taylor, 1990). Soil (5g) was mixed with 10ml of extraction buffer to form a slurry. Five replicate aliquots (1ml) were transferred to 2ml tubes containing five 3mm tungsten carbide balls. The slurry was shaken on a Retsch mixer mill mm300 (Qiagen) for 5 min then centrifuged at 1525 x *g* for 5 min. The clarified soil extract was transferred to a fresh 2ml Eppendorf tube. DNA was extracted using a Promega Wizard® MagneSil™ DNA purification system for food and a Kingfisher mL™ magnetic particle processor following manufacturers protocols. The Kingfisher tubes were prepared as follows. Tube 1 - 1.4 ml of sample containing 50µl of MagneSil™ beads. Tube 2 – 1ml of lysis buffer B (Promega MagneSil™ DNA purification system for food kit). Tubes 3 and 4 – 1ml of 70% ethanol. Tube 5 - 200µl of molecular grade water (BDH). A total genomic DNA programme was used to purify the DNA in each sample. DNA was collected in the 200µl of water in tube 5 and transferred to a clean 1.5ml Eppendorf tube. Using a spectrophotometer, DNA purity and concentration were determined by measuring absorbance at wavelengths 260nm (DNA); 280nm (protein); 320nm (background effects e.g. turbidity) and the absorbance ratio is calculated using the following equation: Absorbance *ratio* = $(A_{\lambda,260} - A_{\lambda,320}) / (A_{\lambda,280} - A_{\lambda,320})$. The ratio of pure DNA is 1.8; any deviation from this indicates contamination.

TaqMan® real-time PCR

DNA extracts from the buffer - MagneSil™ and Kingfisher™ combination giving the greatest yield of DNA free from protein contamination, were used to amplify *Polymyxa* spp. by TaqMan® real-time PCR. TaqMan primers and probes were designed to ITS regions of (i) *P. graminis* (type II) (Ward *et al.*, 1994), primer pair Pgram690f/758r and probe pgram713T (ii) *P. betae*, primer pair *Pbetae*698f/760r and probe *Pbetae* 718T. TaqMan reactions were set up in 96-well reaction plates. Reaction mixtures (25µl per well) contained core-reagent kits (PE-Biosystems), according to manufacturers protocols. DNA extracted from each sample (1µl) was added to the appropriate well. Plates were cycled at generic conditions within the 7700 Sequence detection system using real-time data collection.

TaqMan quantification of Polymyxa DNA in soils

A TaqMan quantification method was developed to determine the amount of *Polymyxa* inoculum in the soils. Sugar beet roots (0.8g) infected with *P. betae* cystosori were ground in sterile distilled water (SDW). The number of cystosori per ml was determined using a haemocytometer. The cystosori were serially diluted in SDW by a factor of 10. Soil samples (0.5g) known to be uninfected with *P. betae* were spiked with 1ml of the appropriate cystosori dilution. Five replicate soil samples were used for each dilution including a negative control where no cysts were added. The samples were vortexed thoroughly to create slurry and centrifuged at 13,000 x *g* for 10 min to pellet cysts and soil. The supernatant was discarded. EDTA based lysis buffer (1ml) was added to each soil sample. Nucleic acid was extracted from the samples and *P. betae* DNA amplified as described previously.

Results and Discussions

Direct detection of *Polymyxa* spp. in soil has not been reported previously. This study has demonstrated a sensitive method of extracting, detecting and quantifying *Polymyxa* spp. DNA in soil using a MagneSil™ and Kingfisher™ extraction system and real-time PCR using TaqMan® chemistry.

Three extraction buffers were compared to determine the efficiency of the buffers to recover DNA in combination with the MagneSil™ and Kingfisher™ extraction system. Using qualitative and quantitative spectrophotometer readings, the purity and quantity of DNA recovered was determined for the six soils. Although the amount of DNA recovered varied slightly between soils for all three buffers, the amount of DNA recovered was consistently highest using the EDTA lysis

buffer (Fig. 1). The amount of DNA recovered was three times greater than that using the phosphate based CTAB buffer and five times greater than that using the EDTA based CTAB buffer. DNA purity was also consistently highest using the EDTA lysis buffer and MagneSil™ extraction system with purity ratios averaging 1.88 for the six soils. Ratios for the EDTA CTAB buffer and phosphate CTAB buffers were 2.41 and 2.54 respectively indicating some degree of contamination most likely with protein or humic acid (Fig. 2).

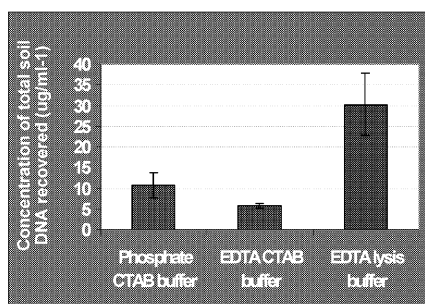

Fig. 1: Mean concentration ($\mu\text{g/ml}^{-1}$) of total soil DNA recovered using different extraction buffers (means for 5 replicates for each of 6 soils \pm SED)

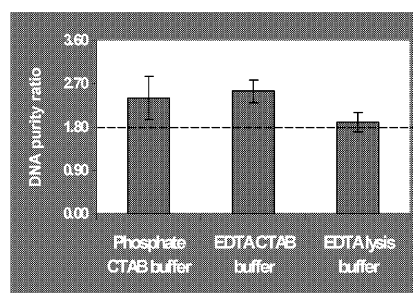

Fig. 2: Mean purity ratio for DNA recovered from soil using different extraction buffers (means for 5 replicates for each of 6 soils \pm SED). Pure DNA is shown by dotted line at absorbance ratio 1.8

TaqMan® primers and probes designed to variable areas within the ITS regions allowed *P. betae* and *P. graminis* (type II) to be amplified from soil (Fig. 3). DNA recovered from soil was of sufficient purity for *P. graminis* DNA to be amplified without dilution to remove soil inhibitors.

DNA extracts from the three *P. betae* soils needed to be diluted 1:10 before amplification

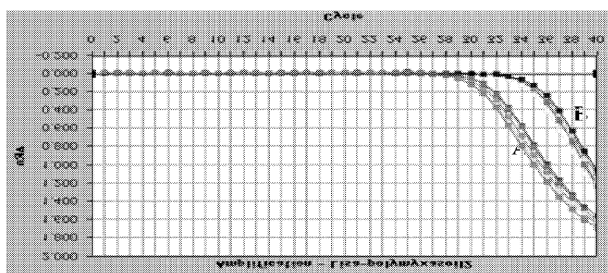

Fig. 3. Amplification plots of *P. graminis* DNA from Wiltshire soil (A) and *P. betae* DNA from Blaxhall (Suffolk) soil (B).

was achieved. The reason for this is not clear, but does not appear to be related to protein contamination. DNA purity ratios for *P. betae* soil extracts averaged 1.81 in comparison to 1.96 for *P. graminis* soil extracts. It is likely that the extracts from *P. betae* soil contained more inhibitors e.g. humic acid, however, as humic acid does not absorb at $\lambda 360\text{nm}$ it is difficult to determine the degree of contamination.

A method was developed to quantify *Polymyxa* spp. inoculum in soil. The extraction method selected was found to be highly efficient at recovering *P. betae* from uninfected soil samples spiked with standard dilutions of *P. betae* cystosori. The recovered *P. betae* DNA was amplified by TaqMan® PCR and a standard curve was constructed by plotting the log number of *P. betae* cystosori for each standard dilution versus TaqMan C_T value (threshold cycle at which first PCR

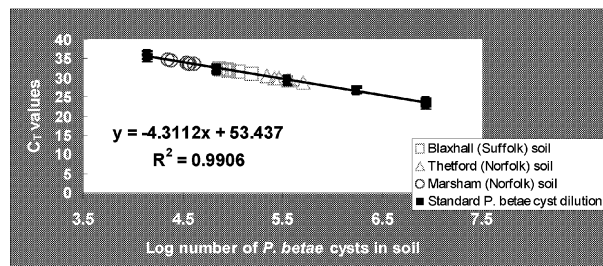

Fig. 4: A standard curve showing the relationship between TaqMan C_T values versus the log number of *P. betae* cysts in soil. The quantity of *P. betae* in each soil was calculated by extrapolating from the curve.

products are detected). The quantity of *P. betae* inoculum in the three original soils was extrapolated from the standard curve. The results showed that the Thetford soil contained the highest amount of *P. betae* inoculum and the Marsham soil the lowest (Fig. 4).

The methods developed here are fast and sensitive. Total extraction and PCR time was less than one day compared to current detection methods which involve 6 week bait tests and lengthy Most Probable Number (MPN) assays. Another advantage of this method is that it avoids use of spin columns where significant amounts of DNA can be lost. This may be important where target inoculum levels are low in the soil, or where accurate quantification is needed.

Direct soil detection could have a number of uses. If reliable and reproducible, this technology has the potential to be used to predict disease risk in farmland. For soil-borne virus diseases in particular, these techniques could be modified in order to go one step further by detecting the causative agent, e.g. BNYVV, SBWMV and BaYMV. In addition, direct soil detection could be used in epidemiological studies to quantify the number of viruliferous *Polymyxa* cysts in soil after growing cultivars of with different levels of viral resistance. Data obtained could be useful in modelling the spread of the diseases and for decision-making on future disease containment strategy. The value of this technique for generic detection of soil-borne disease needs to be examined, but these methods have potential to be used to detect a range of other soil-borne diseases including spraing, club root, *Fusarium* spp. and *Rhizoctonia* spp.

References

- Bell, K.S. *et al.*, (1999). Detection and quantification of *Spongospora* f.sp. *subterranea* in soils and on tubers using specific PCR primers. *European Journal of Plant Pathology* 105: 905-915.
- Lee, S.B. & Taylor, J.W. (1990). Isolation of DNA from fungal mycelia and single spores. In Innis, M.A. Gelfand, D.H., Sninsky, J.J., White, T.J. eds. *PCR Protocols. A Guide to Methods & Applications*. San Diego: Academic Press 282-287.
- Lohdi *et al.*, (1994). *Plant Molecular Biology reporter* 12: 6-13.
- Ward, E., Mutasa, E.S., Adams, M.J. Collier, C.R., & Asher, M.J.C. (1994). Characterisation of *Polymyxa* species. In *proceedings of the second symposium of the International Working Group on plant Viruses with Fungal Vectors* (ed. C.Hiruki), pp. 87-90. American Society of Sugar Beet Technologists: Denver, U.S.A.

DIFFERENCES IN ZOOSPORANGIAL ROOT INFECTION OF SOME POTATO VARIETIES INOCULATED WITH JAPANESE AND FOREIGN FIELD ISOLATES OF *SPONGOSPORA SUBTERRANEA* F. SP. *SUBTERRANEA*

Takato Nakayama¹, Ueli Merz², Akio Nakagawa³, Toshiaki Takehara³ and Tadayuki Shimanuki¹

¹ National Agricultural Research Center for Hokkaido Region, Sapporo 062-8555, Japan

² Institute of Plant Sciences, Swiss Federal Institute of Technology, 8092 Zürich, Switzerland

³ National Agricultural Research Center, Tsukuba 305-8666, Japan

Summary

The difference of virulence on potato between Japanese and foreign field isolates of *Spongospora subterranea* f.sp. *subterranea* were investigated. The solution culture bioassay revealed that two Japanese resistant cultivars 'Yukirasha' and 'Hokkaikogane' are rather susceptible to root infection by one Japanese isolate. It was supposed that the tuber and root susceptibility do not necessarily correlate with each other. The possibility of variation in virulence among regionally separate Sss isolates was suggested by comparing the severity of root infection on some cultivars after incubation with Sss from Japan, Switzerland and New Zealand.

Introduction

Powdery scab caused by a *Plasmodiophoraceae*, *Spongospora subterranea* f. sp. *subterranea* (Sss) is considered as one of the most serious problem among the fresh and seed tuber producers in Japan. The disease was first reported in 1954 in Hokkaido, the northernmost island of Japan (Asuyama, 1954), afterwards it was recorded in almost all potato producing area in Japan (1981). Sss is also known as a vector of *Potato mop-top virus* (Jones and Harrison, 1969), however, the virus has not been detected in Japan for over 20 years after the first report (Imoto *et al.*, 1980). In order to avoid the damage from powdery scab, planting healthy seed, improvement of soil drainage, crop rotation (at least 4 year) and soil application of fungicides, fluazinam and flusulfamide, are recommended. Although it is crucial to clarify the variation of pathological characteristics among field isolates in order to establish the effective strategy for disease control, inter-regional difference in virulence on potato cultivars between Sss isolates has never been investigated. In this study, (1) the virulence of Japanese Sss isolates on some potato cultivars, (2) regional differences in virulence between Japanese and foreign field isolates of Sss, were investigated by cultivation with seed inoculation and solution culture bioassay.

Materials and Methods

Peelings of heavily infected potato skin containing scabbed region were dried under room temperature. Seed tubers were inoculated with the suspension of crushed peelings and planted in plastic pot filled with sterilized soil. The pots were placed in green house conditioned at 20°C and kept the soil wet to promote the disease by put the pots in the tray filled up water in 1 cm depth. Diseased tubers were checked after 70 days.

The peelings mentioned above were homogenized in tap water and sieved to collect the fraction between 40 to 80 µm. This inoculum was used for the solution culture bioassay described by Merz (1989) in order to study root infection. Newly generated roots of potato tissue culture plantlet grown on MS medium were immersed in the nutrient solution containing the inoculum for 1 day at 18°C to establish infection, followed by incubation in fresh nutrient solution for 7 days. The whole roots were stained with 0.3% water blue and observed the zoosporangia

or plasmodia formed on the epidermal cells under stereomicroscope. The root infection was evaluated by scoring from 0 (no infection) to 5 (heavy infection are observed regularly).

Results

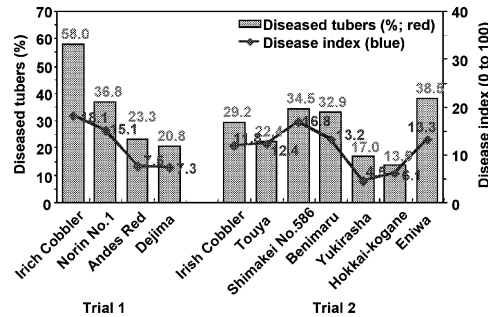

Fig. 1 Susceptibility of 10 potato cultivars to Japanese field isolate of *Spongospora subterranea* f.sp. *subterranea* in the green house experiment using seed tuber inoculation

Disease Index = $f^2(nN_s) / 4N \times 100$
 N_s : the number of diseased tuber with scale 0 (no symptom), 1 (less than 15 scabs on surface), 2 (16 to 30 scabs on surface), 3 (less than 30% of surface covered with scabs) and 4 (over 30% of surface covered with scabs),
 N: the number of tuber checked

Tuber susceptibility of Japanese cultivars in the green house experiment

Seed tuber inoculation could successfully reveal the susceptibility of potato cultivars to powdery scab. ‘Irish Cobbler (Danshaku-imo)’, the most popular cultivar in Japan, was quite susceptible to tuber attack by the Japanese Sss isolate that was sampled in Hokkaido (tentatively named JP1). ‘Yukirasha’ and ‘Hokkaikogane’ were shown to be relatively resistant. Although ‘Eniwa’ has been considered as a resistant cultivar (1981), their tubers were infected comparably to ‘Irish Cobbler’ in this experiment (Fig. 1).

Susceptibility of potato cultivars to the root infection by Japanese Sss isolates

In the solution culture bioassay, the root infection severities of 15 Japanese cultivars by JP1 were moderate to heavy regardless of their tuber susceptibilities. ‘Yukirasha’ and ‘Hokkaikogane’ which are relatively resistant on tubers as shown in Fig. 1 exhibited little resistance against root infection, whereas ‘Eniwa’ was infected slightly (Fig. 2).

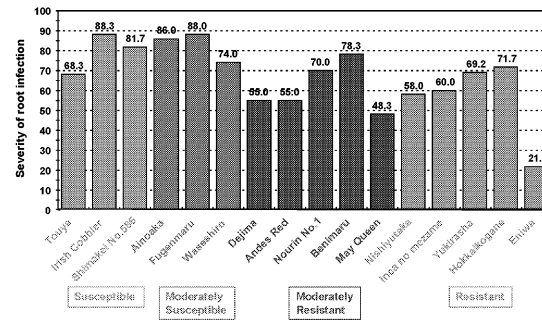

Fig. 2 Root infection on 16 potato cultivars after the incubation with Japanese field isolate (JP1) of *Spongospora subterranea* f.sp. *subterranea*
 Tuber susceptibility of each cultivar determined by field test is shown below the name of cultivar in the same color.
 Severity of root infection = $f^2(nN_s) / 5N \times 100$, N_s : the number of plant with scale 0 (n=0 to 5), N: the number of plant examined

incubation with JP1. In contrast, ‘Desiree’ and ‘Bintje’ suffered slight root infection (Fig. 4).

Comparison of the virulence of Swiss, New Zealand and Japanese isolates

Virulence of Japanese (JP1), Swiss (CH) and New Zealand (NZ) isolates of Sss on the roots of 4 potato cultivars (‘Agria’, ‘Desiree’, ‘Granola’ and ‘Irish Cobbler’) were compared. Agria and Irish Cobbler were highly susceptible (score 4 to 5), and Granola was moderately susceptible (score 2 to 3) against all three isolates. ‘Desiree’ showed resistance against root infection by JP1, however CH and NZ infected heavily on the roots (Fig. 5).

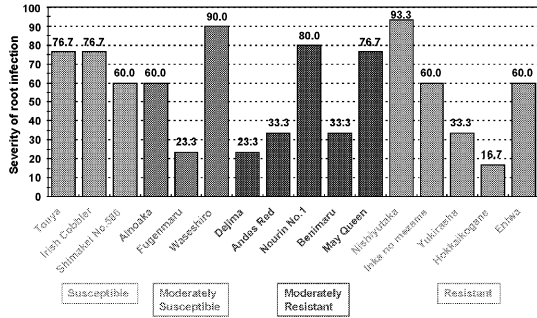

Fig. 3 Root infection on 16 potato cultivars after the incubation with Japanese field isolate (JP2) of *Spongospora subterranea* f.sp. *subterranea*
Tuber susceptibility of each cultivar determined by field test is shown below the name of cultivar in the same color.
Severity of root infection: See the legend of Fig. 3

been made from the field experiment checking the susceptibility of 33 cultivars, in which little correlation was observed between root hair and tuber infection (1981). Another point of view, this may imply the possibility that planting these resistant cultivars contribute to maintain or even raise the population of the pathogen through its multiplication on the roots. In the microscopical observations, however, it was recognized that most of the zoosporangia observed in epidermal cells of 'Gladiator' were small and it has developed into only a few cells. These findings may indicate that resistance of potato against powdery scab may not be expressed in the very first contact with pathogen (root hair infection or epidermal cell infection), but in the later stage of infection cycle.

The variation of virulence within Sss isolates has never been demonstrated so far (Harrison *et al.*, 1997). In this study, two Japanese isolates JP1 and JP2 showed the difference in virulence on the roots of particular cultivar, especially against 'Eniwa', 'Hokkaikogane' and 'Fugenmaru'. In addition, the virulence of JP1 on e.g. 'Desiree' or 'Nicola' was clearly distinguishable from Swiss or New Zealand isolates. These observations are suggestive of the possible variation in virulence among these regionally separate isolates. Recently, molecular variations on the ribosomal ITS sequences in numbers of Sss isolates have been described (Bulman *et al.*, 1998; Qu *et al.*, 2000). However it is still uncertain whether these molecular variations have some connection to the variation in virulence. Further investigation will be required to clarify the possibility of variation in Sss isolate.

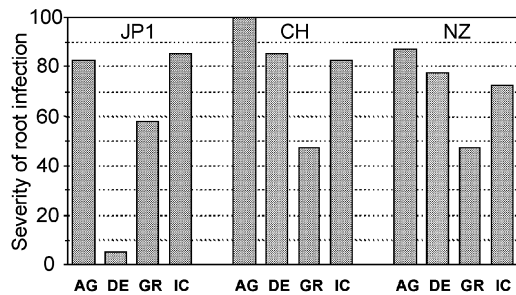

Fig. 5 Root infection of Japanese (JP1), Swiss (CH) and New Zealand (NZ) isolates of *Spongospora subterranea* f.sp. *subterranea* on 4 potato cultivars
AG: Agria, DE: Desiree, GR: Granola, IC: Irish Cobbler,
Severity of root infection: See the legend of Fig. 3

Discussion

In this study, the solution culture bioassay could reveal that Japanese resistant cultivars 'Yukirasha' and 'Hokkaikogane' are rather susceptible to root infection by JP1. The isolate also infected moderately to heavily on the root of 'Gladiator', a New Zealand cultivar with high resistance to powdery scab (Genet *et al.*, 1995). These results as shown in Figures 3, 4 and 5 may lead to the supposition that the tuber and root susceptibility do not necessarily correlate with each other. Similar consideration has

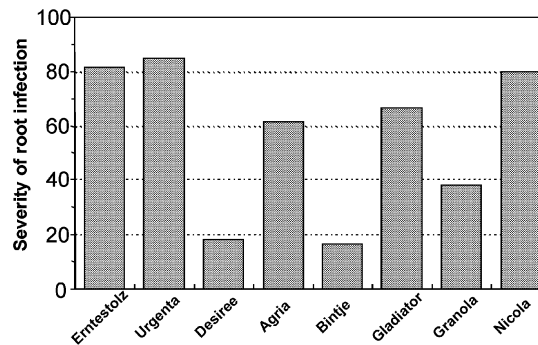

Fig. 4 Root infection on 8 potato cultivars after the incubation with Japanese field isolate (JP1) of *Spongospora subterranea* f.sp. *subterranea*
Severity of root infection: See the legend of Fig. 3

References

- Asuyama, H. (1954). Powdery scab disease of potato. *Shokubutsu bôeki (Plant Protection)* 8: 510-513. (in Japanese)
- Bulman, S.R. and Marshall, J.W. (1998). Detection of *Spongospora subterranea* in potato tuber lesions using the polymerase chain reaction (PCR). *Plant Pathology* 47: 759-766.
- Experiments on Ecology of Occurrence and Control of Powdery Scab, *Spongospora subterranea* (Wallroth) Lagerheim of Potato (1981), Res. Bull. Tsumagoi Potato Foundation Stock Seed Farm, No. 15, Tsumagoi, Gunma, Japan. (in Japanese with English abstract)
- Genet, R.A., Braam, W.F., Gallagher, D.P., Anderson, J.A.D. and Lewthwaite, S.L. (1995). 'Gladiator': a new potato cultivar with high resistance to potato cyst nematode and powdery scab suitable for french fries and fresh market. *New Zealand Journal of Crop and Horticultural Science* 23: 105-107.
- Imoto, S., Tochiara, H., Iwaki, M. and Nakamura, K. (1980) The occurrence of potato mop-top disease in Japan, *Ann. Phytopath. Soc. Jpn.* 47: 409. (abstract in Japanese)
- Jones, R. A. C. and Harrison, B. D. (1969) The behaviour of *Potato mop-top virus* in soil, and evidence for its transmission by *Spongospora subterranea* (Wallr.) Lagerh. *Ann. Appl. Biol.* 63: 1-17.
- Harrison, J.G., Searle, R.J. and Williams, N.A. (1997). Powdery scab disease of potato - a review. *Plant Pathology* 46: 1-25.
- Merz, U. (1989) Infectivity, inoculum density and germination of *Spongospora subterranea* resting spores: a solution-culture test system. *Bulletin OEPP* 19: 585-592.
- Merz, U. (2000). Powdery Scab. Research in Switzerland. pp. 67-71. *In Proceedings of The First European Powdery Scab Workshop, Aberdeen, Scotland.*
- Qu, X.-S., Kavanagh, J.A. and Egan, D. (2000). *Spongospora subterranea* f. sp. *subterranea*: molecular variation, PCR detection and isolation in vitro. pp. 75-77. *In Proceedings of The First European Powdery Scab Workshop, Aberdeen, Scotland.*

INVESTIGATION OF EPIDEMIOLOGY OF SOILBORNE CEREAL MOSAIC VIRUS IN THE GERMAN COUNTRY SAXONY-ANHALT

U. Kastirr, F. Rabenstein, T. Kühne

Federal Centre for Breeding Research on Cultivated Plants, Institute of Resistance Research and Pathogen Diagnostics, Theodor-Roemer-Weg 4, D-06449 Aschersleben, Germany

Summary

The dissemination of *Polymyxa graminis* transmitted viruses like *Soil-borne cereal mosaic virus* (SBCMV), *Soil-borne wheat mosaic virus* (SBWMV) and *Wheat spindle streak mosaic virus* (WSSMV) in cereals is an ongoing process in Europe, USA and Asia. Over the last 20 years these bipartite viruses were detected in different regions of Germany, predominantly in rye and triticale. Very frequently the plants are mixed infected with SBCMV and WSSMV. Epidemiological investigations with *P. graminis* populations of different origin revealed a diverse transmission efficiency in case of SBCMV. In addition, isolates of this virus are remarkably variable in their genome.

Because the level of resistance among approved cultivars and current breeding material of wheat, rye and triticale is very low a program to evaluate genetic resources under natural and controlled conditions was started. Up to now resistance to SBCMV has been found only in two wheat accessions from the gene bank in Gatersleben.

Introduction

The epidemiological investigations were focused on the dissemination of SBCMV and WSSMV in the main rye growing areas of the countries Saxony-Anhalt, Thuringia and Saxony during the growing season from February till May 2002. Distribution of the viruses, separately or in combination, in different shoots of individual plants was analysed to ensure an optimal sampling for routine diagnosis. The occurrence of various forms of SBCMV isolates in the different locations was recorded. Finally a program was started for screening of genetic resources of rye and wheat to identify sources of resistance to SBCMV that can be introduced into breeding programs.

Materials and Methods

From February till May 2002 in each of six fields located in the main rye and triticale growing region of Saxony-Anhalt 50 rye plants were continuously monitored for virus occurrence by DAS-ELISA using specific antisera to SBCMV, SBWMV and WSSMV from our own production.

To identify and differentiate the various forms of SBCMV isolates (Koenig *et al.*, 1999) the following pairs of specific primers were designed based on published data: Pa/Pb (5'-TTGAATTTGATGGCTTCTATTCA-3' / 5'-GTGGATGAAAGTCATAAATTCAG-3') and P2/P3 (5'-CCTTTCTTACCAGGATAAG-3' / 5'-ACATTCTCTGATCTGCAAC-3'). To amplify fragments of the viral genome by IC-RT-PCR crude sap from infected leaves was incubated overnight at 4 °C in tubes, that were pre-coated with SBCMV IgG. Applying sequence specific primers the RNA was transcribed and amplified by PCR. The obtained DNA fragments were visualised in agarose gels, subsequently extracted, ligated into the vector pGEM-T (Promega) and sequenced in both orientations on a ALF-Express automated sequencer (Pharmacia) using Cy5-labelled primers and a ThermoSequenase Cycle Sequencing Kit (Amersham Pharmacia Biotech). Sequence data were processed by means of the software package Vector NTI 6 (InforMax Inc.).

For analysing the resistance to SBCMV seedlings of varieties, breeding lines and gene bank

accessions of rye, wheat and triticale were grown for 8 weeks in infested soil at 18 °C before leaves were tested for the presence of virus by DAS-ELISA.

Results and Discussion

Huth (2000) recently reported about a continuous dissemination of soil-borne viruses in rye and triticale. In the course of our monitoring program several new locations infested with SBCMV and WSSMV were detected in 3 districts of Saxony-Anhalt (Fig 1). For the first time patches of SBCMV infected rye plants were observed in the countries Saxony and Thuringia, too (Kastirr and Kühne, 2002). From February till May in each of six fields located in the district Anhalt-Zerbst (Saxony-Anhalt) 50 rye plants were analysed monthly for the presence of virus by DAS-ELISA using specific antisera to SBCMV, SBWMV, and WSSMV from our own production. First symptoms appeared in February. SBCMV and WSSMV occurred in all fields, although the frequency of WSSMV at the location Prödel was very low (Fig. 2). The dynamics of multiplication of the two viruses in the monitored plants was different at different locations. The SBWMV was never found in rye and triticale in these regions.

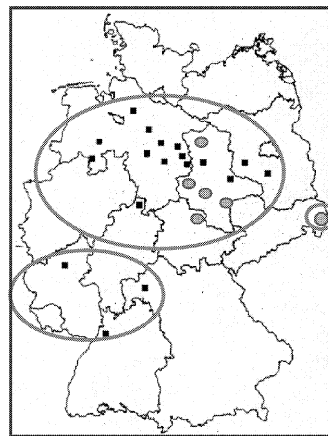

Fig. 1: Dissemination of SBCMV in Germany (■ - Huth, 2000; ● - Kastirr, 2002)

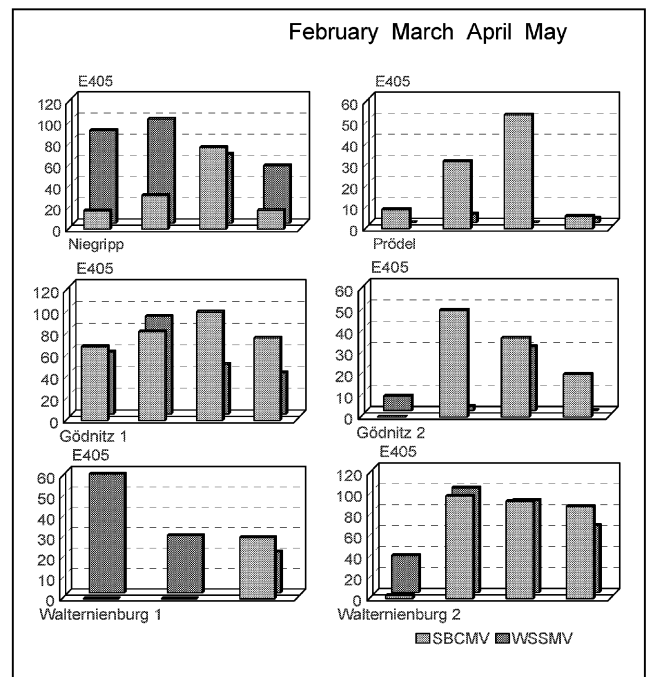

Fig. 2: Evidence of virus multiplication in winter rye plants of six fields during growing season

The distribution of the two viruses in mixed infected plants was different (Fig. 3). Some shoots of an individual plant were mixed infected while other contained only one type of virus or were completely healthy.

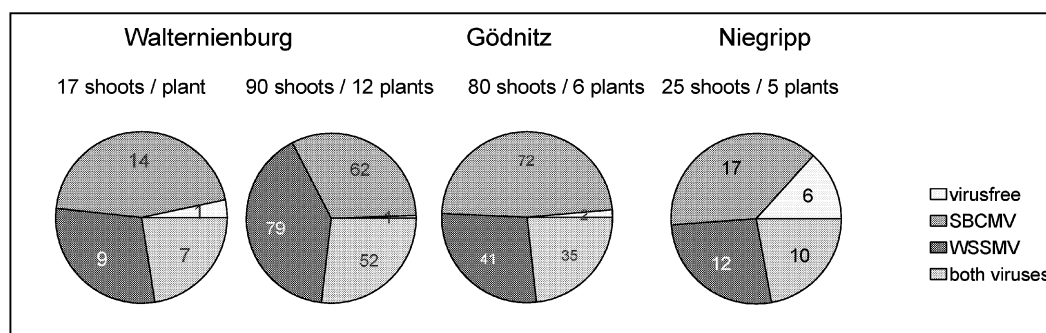

Fig. 3: Variability of virus infection in shoots of infected plants from 3 different fields

Table 1: Occurrence of several isolate forms of SBCMV in different geographical regions

Region	Isolate form
Glentorf	C
Engehausen	C
Eickeloh	C
Eilte	C
Dornburg	C
Gödnitz	C
Niegripp	G,C
Prödel	G,C
Walternienburg	G
Schackenthal	G
Güterglück	O / C
Töppel	O

Isolates of the SBCMV are remarkably variable in their nucleotide sequence. The C-, G- and O-forms of the virus were detected in different locations (Table 1).

As a first step to control the SBCMV in future a number approved varieties, breeding lines, and genotypes from the gene bank in Gatersleben were screened for resistance.

The level of resistance among wheat, rye and triticale materials concluding from testing under controlled conditions in infested soil (Kastirr *et al.*, 2002) is very low.

Only a few plants in two accessions of *T. aestivum* exhibited a significantly reduced susceptibility (Table 2).

Table 2: Screening of different cereals for resistance to SBCMV under controlled conditions

Cereal crop	Number tested accessions	Resistance
Wheat varieties	35	No
<i>Triticum</i> spp.	20	No
<i>T. aestivum</i>	45	No
	2	Yes
Rye varieties	25	No
<i>Secale cereale</i>	240	No
Triticale varieties	10	No

Acknowledgement

We like to thank the plant protection offices of Saxony-Anhalt, Saxony and Thuringia for their support in monitoring virus occurrence and the gene banks of IPK Gatersleben and BAZ Braunschweig for providing us with seed materials.

References

- Huth, W. (2000). Im Getreidebau in Deutschland und in Europa wird eines der größten phytopathologischen Probleme erwartet. Die bodenbürtigen Viren des Weizens und Roggens. *Nachrichtenbl. Deut. Pflanzenschutzd.* 52, 196-198.
- Kastir, U., and Kühne, T. (2002). Epidemiology of *Soil-borne cereal mosaic virus* in Germany. *VIII th Int. Plant Virus Epidemiology Symposium, Aschersleben / Germany 12-17 May, 2002*, 89.
- Kastir, U., Rabenstein, F., and Kühne, T. (2002). Evaluierung von Roggen und Weizen auf Resistenz gegen das *Soil-borne cereal mosaic virus* (SBCMV) unter kontrollierten Bedingungen. *Vort. Pflanzzüchtg.* 54, 263-266.
- Koenig, R., Pleij, C. W. A., and Huth, W. (1999). Molecular characterization of a new furovirus mainly infecting rye. *Arch. Virol.* 144, 2125-2140.

SPATIAL ASSOCIATION AND DISTRIBUTION OF BEET NECROTIC YELLOW VEIN VIRUS AND BEET SOILBORNE MOSAIC VIRUS IN SUGAR BEET FIELDS

F. Workneh, E. Villanueva, and C. M. Rush

Texas Agricultural Experiment Station, Texas A&M University, Bushland 79012

Summary

Beet necrotic yellow vein virus (BNYVV) and *Beet soilborne mosaic virus* (BSBMV) are closely related viruses sharing many biological and morphological characteristics. Both viruses are vectored by *Polymyxa betae* Keskin. In 1999, spatial association and covariation of the viruses was investigated in 4 sugar beet fields in Colorado, Minnesota, North Dakota, and Texas. In each field rhizosphere soil was collected from large- and small-size quadrats. The viruses were bioassayed by planting bait plants in the soils in the greenhouse. The incidence of the viruses then was determined using DAS-ELISA. The viruses were detected in greater frequencies singly than in association. Overall, their spatial association varied among fields ranging from 1% in the field in Texas to 27.9% in the field in Minnesota. Geostatistical analysis of the data indicated that the spatial patterns of both viruses also varied among fields ranging between random and aggregated distributions, the size of the grids playing a significant role in determining the patterns of distribution. Both viruses exhibited more or less similar spatial patterns and, thus, a sampling strategy employed for one of the viruses may be utilized for the other as well.

Introduction

Beet necrotic yellow vein virus (BNYVV) and *Beet soilborne mosaic virus* (BSBMV) are widely distributed in sugar beet growing regions of the United States. Both viruses are vectored by the soilborne *Plasmodiophoromycete polymyxa betae* Keskin and are similar in many morphological and biological characteristics (Heidel et al., 1997; Liu and Duffus, 1988). BNYVV causes rhizomania of sugar beet, which is a severe disease of sugar beet worldwide affecting sugar beet yield and quality (Rush and Heidel, 1995). Unlike BNYVV, BSBMV had not been reported outside of the United States and its effect on sugar beet yield and quality is variable, depending on soil moisture and perhaps other variables (Piccinni and Rush, 2000). The two viruses differ primarily in serology, host range, and symptom expression on various host plants including sugar beets (Wisler et al., 1994).

A study in Texas showed that both viruses can be detected in the same sugar beet field (Heidel et al., 1994). In addition, when sugar beets were grown in bulked rhizosphere soil samples, both viruses were able to infect the same sugar beet root (Heidel et al., 1994). Previous studies by Mahmood and Rush (1999), Piccinni and Rush (2000), and Wisler et al. (2001) showed there is some form of interaction between the two viruses. The present investigation was initiated to determine the association and distribution patterns of the two viruses in sugar beet fields. Knowledge of their spatial association and covariation may give some insight into the potential for synergetic or antagonistic interaction under field conditions.

Materials and Methods

In the summer of 1999, rhizosphere soil was collected from sugar beet fields in Colorado (Fort Morgan area), Minnesota (Wilmar area), North Dakota (Fargo area), and Texas (Bushland) (one field from each state). The sizes of the fields ranged from 18 to 32 ha. In each field samples were collected at two quadrat sizes. First, the entire field was divided into grids of 0.4ha (large quadrats), and second, one of the large quadrats was arbitrarily selected and

further divided into 3.4m x 7.6m quadrats (small). The viruses were assayed by growing bait plants in the soil in the greenhouse and their incidence was determined using the double antibody sandwich enzyme-linked immunosorbent assay (DAS-ELISA) with polyclonal antibodies as described earlier (Heidel et al., 1994). Categorical data from the DAS-ELISA were subjected to frequency and geostatistical analyses to determine the spatial association and distribution of the two viruses.

Results

In all fields, in both large and small quadrats, the viruses were detected in greater than 49% of the samples. In all cases the viruses were detected in greater frequencies singly than in association. The frequencies of samples in which both viruses were detected in the same rhizosphere sample ranged from 1% in samples from Texas to 27.9% in samples from Minnesota, and overall, the viruses were not significantly associated. The spatial pattern of the viruses varied among fields but largely depended on the sizes of the quadrats. Semivariograms for BNYVV in samples collected from Colorado from small quadrats exhibited sinusoidal behavior indicating the existence of spatially periodic component: alternating spatially continuous and discontinuous locations as separation distance increased (Fig. 1A). Spatial pattern of BSBMV exhibited similar behavior but the sinusoidal pattern was less apparent (tending more toward randomness) than that of BNYVV (Fig. 1B). Samples collected from the small quadrats in Minnesota showed spatial dependency within a range of 29.6m (Fig. 2A). Semivariance for BNYVV was best described by the spherical model ($r^2 = 0.97$). The spatial pattern of BSBMV had less structure than that of BNYVV with effective range of 13.8m (Fig. 2B), and the pattern was best described by exponential model ($r^2 = 0.86$). There was only one sample in which BNYVV was detected in samples from the field in Texas and, hence, its spatial pattern was not determined. The spatial patterns of BSBMV showed no structural pattern. A constant semivariance was observed in relation to an increase in separation distance (Fig. 3A), which is one of the characteristics of random pattern (Davis, 1986). Semivariograms for data from large quadrats (0.4 ha) for both viruses in all fields showed random spatial pattern (Fig. 3B). Since the semivariograms of data from all the large-quadrat fields were similar, only that of one field representing spatial patterns of both viruses is presented.

Discussion

BNYVV and BSBMV are closely related pathogens and are widely distributed in sugar beet growing regions of the United States. However, their spatial association and covariation in sugar beet fields had never been investigated. Reports by Mahmood and Rush, (1999); Piccinni and Rush (2000); and Wisler et al. (2001) showed that the viruses exhibit some form of interaction under experimental conditions. In this study, both viruses were detected in all fields but the frequency in which both viruses were detected in the same rhizosphere varied among fields and was generally low. However, the fact that they were spatially associated and exhibited similar distribution patterns suggests that interaction (synergetic or antagonistic) between the viruses during infection or disease development is possible under field conditions. Variations among fields suggest that the level of interaction between the viruses may depend on the degree of their association in a given field. The fact that both pathogens exhibited similar patterns of spatial distribution is interesting but not surprising since both pathogens are vectored by the same pathogen and, in a real sense, we investigated the spatial patterns of the viruliferous vector. It would be more interesting to estimate the frequency and distribution pattern of one virus from that of the other in fields in which both are prevalent. This may be possible in fields where distributions of both viruses are spatially continuous and the two viruses are strongly associated. In the present study, the association between the two viruses overall was weak and only one of the fields sampled at small quadrats (and none at large quadrats)

showed spatial continuity. Sampling distances affect the outcome of spatial pattern investigation. Spatial pattern of a subject under study may appear random if sampled at distances beyond the range at which it is spatially dependant. In this study, all fields sampled at large distances exhibited random patterns. These distances may have been too large to detect the existence of spatial continuity. It is still possible that spatial patterns of the viruses in these fields may not have turned out to be random if they were further sampled at smaller distances than the smallest grids used in this study. Similarity in spatial patterns of the two suggests that a similar sampling method can be employed for both viruses. However, more fields may need to be sampled at various quadrat sizes to arrive at a sound conclusion on association and distribution of the viruses.

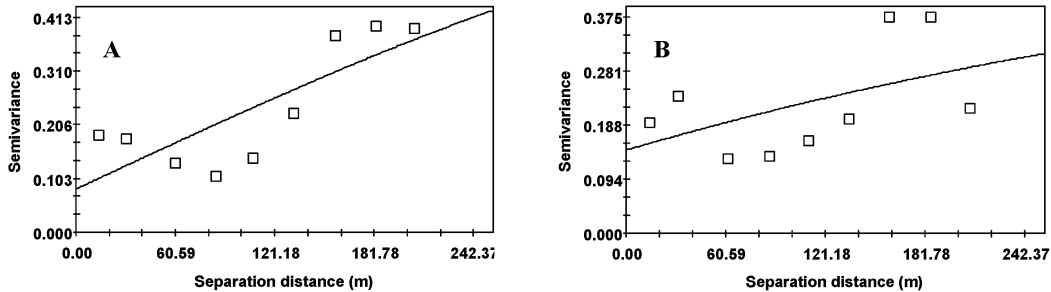

Fig. 1. Semivariograms of spatial patterns of *BNYVV* (A) and *BSBMV* (B) in the field sampled from small quadrats (3.4m \times 7.6m) in Colorado.

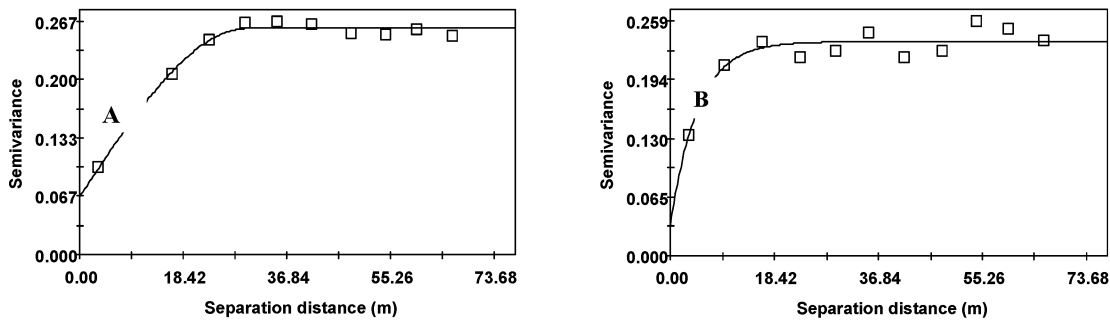

Fig. 2. Semivariograms of spatial patterns of *BNYVV* (A) and *BSBMV* (B) in the field sampled from small quadrats (3.4m \times 7.6m) in Minnesota.

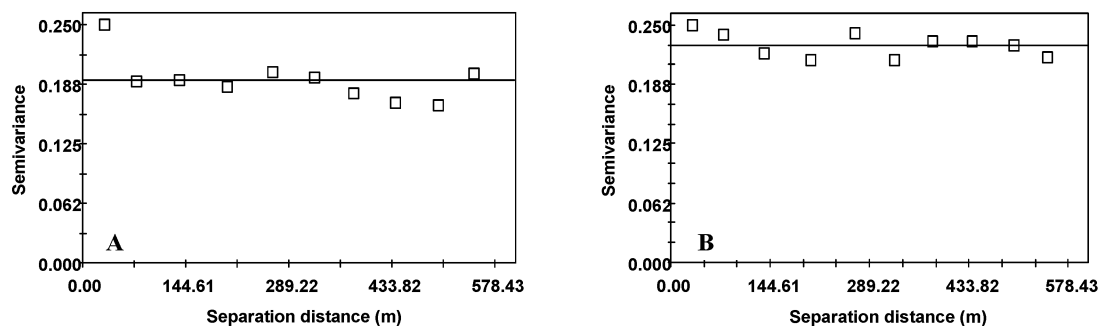

Fig. 3. Semivariograms of the spatial patterns of *BSBMV* in fields sampled from small quadrats (3.4m x 7.6m) in Texas (A) and *BNYVV* sampled from large quadrats (0.4ha) in Minnesota (B).

References

- Davis, J. C. 1986. *Statistics and Data Analysis in Geology*. 2nd ed. John Wiley, New York.
- Heidel, G. B., Rush, C. M., Kendall, T. L., Lommel, S. A., and French, R. C. 1997. Characteristics of *Beet soilborne mosaic virus*, a furo-like virus infecting sugar beet. *Plant Dis.* 81:1070-1076.
- Heidel, G. B., and Rush, C. M. 1994. Distribution of *Beet necrotic yellow vein virus*, *Beet distortion mosaic virus*, and an unnamed sugar beet virus in Texas and New Mexico. *Plant Dis.* 78:603-606.
- Liu, H.-Y., and Duffus J. E. 1988. Three distinct viral pathogens similar in particle morphology with rhizomania of sugar beet. *Phytopathology* (abstract) 78:1583.
- Mahmood, T., and Rush, C. M. 1999. Evidence of cross-protection between *Beet soilborne mosaic virus* and *Beet necrotic yellow vein virus* in sugar beet. *Plant Dis.* 83:521-526.
- Piccinni, G. and Rush, C. M. 2000. Determination of optimum irrigation regime and water use efficiency of sugar beet grown in pathogen-infested soil. *Plant Dis.* 84:1067-1072.
- Wisler, G. C., Liu, H.-Y., and Duffus, J. E. 1994. *Beet necrotic yellow vein virus* and its relationship to eight sugar beet furo-like virus forms in the United States. *Plant Dis.* 78:995-1001.
- Wisler, G. C. Lewellen, R. T., H.-Y. Liu, Wintermantel, W. M. 2001. Interaction between *BNYVV* and *BSBMV* in rhizomania resistant and susceptible varieties and effects on beet development (abstract). *J. Sugar Beet Research* 38:106.

PHYSIOLOGY OF PIGMENTS IN SUGAR BEETS INFECTED WITH RHIZOMANIA

K. Steddom, G. Heidel, D. Jones, and C.M. Rush

Texas Agricultural Experiment Station, Bushland, Texas 79012

Summary

Symptoms of rhizomania of sugar beet commonly include a yellowing of the foliage that can be described as “fluorescent”. At the end of the growing season, as foliar nitrogen levels decline in healthy beets, the yellowing due to rhizomania can be difficult to distinguish from nitrogen deficiency. In this study, we have shown infection by *Beet necrotic yellow vein virus* resulted in a reduction of leaf nitrogen, chlorophylls, carotenoids, and betacyanins when compared to healthy sugar beets. Natural, end-of-season nitrogen depletion in healthy sugar beets could not account for these differences. These pigment differences could be used to detect and differentiate rhizomania in the presence of nitrogen deficiency.

Introduction

Rhizomania is a viral disease of sugar beets (*Beta vulgaris* L.) caused by *Beet necrotic yellow vein virus* (BNYVV). BNYVV is vectored by the zoosporic fungus *Polymyxa betae* Keskin (Rush and Heidel 1995) and causes a proliferation of roots, yellowing of the foliage, and a reduction in extractable sucrose (Tuitert and Hofmeester 1994; Rush and Heidel 1995). In commercial sugar beet fields, initial nitrogen application is limited in order to reduce plant nitrogen content at the end of the season, leading to higher levels of extractable sucrose (Burcky et al. 1978; Winter 1998). The yellowing caused by rhizomania is often confused with nitrogen deficiency in healthy sugar beets. The similarity of these symptoms makes it difficult to accurately assess the extent of rhizomania and poses problems for predicting sugar yields. Remote sensing can be used to quantify plant pigments (Gitelson and Merzlyak 1997; Gamon and Surfus 1999; Gitelson et al. 2001; Gitelson et al. 2002), and has the potential to be used for identification and quantification of plant diseases. This study attempts to quantify the changes in pigment concentrations associated with healthy and rhizomania-infected sugar beets.

Materials and Methods

In the 2000 growing season, three fields east of Fargo ND and four fields west of Willmar MN were selected. The study was repeated in the 2001 growing season with three fields east of Fargo, and two fields west of Willmar. Fields were selected that showed discrete yellow spots with root symptoms characteristic of rhizomania and nearby regions that appeared healthy. In each field a symptomatic spot and a near-by healthy-appearing area were selected. In order to observe the natural decline in nitrogen content in healthy beets, fields were sampled four times in 2000 from August through October and three times in 2001 during August and September. As the season progressed, the healthy beets were observed to grow more yellow until differentiation of the diseased spots was difficult near harvest. At each sampling date, four samples were collected from each spot giving eight samples per field. Four to six leaves and feeder root tissue from the lateral groove of the taproot were collected from each plant, placed in sealed plastic bags and transported back to the lab.

The presence of BNYVV was assayed by ELISA on feeder root tissue from the lateral groove of the tap root as previously described (Heidel and Rush 1994). Leaf samples were cut into 4 cm wide strips and one piece was randomly selected from each sample for gathering individual leaf reflectance as described below. All samples were processed within 24 hours of field collection. Following acquisition of leaf spectra, leaf samples were dried at 45° C. Samples

from 2 fields in the Fargo area and 2 fields from the Willmar area from the first and last sampling dates in 2001 were sent to the Texas A&M Soil, Water, and Forage Testing Laboratory, College Station Texas. Samples were analyzed for nitrogen, sodium, phosphorus, potassium, calcium, manganese, iron, copper, zinc, and magnesium.

Reflectance of intact, individual leaves from the field samples was measured with a hyper-spectral ASD FieldSpec FR radiometer (Analytical Spectral Devices, Inc. Boulder, CO) attached to a Li-Cor Li-1800-12 integrating sphere (Li-Cor, Lincoln, NB). Irradiance for dark readings, a packed barium sulfate standard, and upper leaf reflectance were measured. Each reading was the result of 5 replicate subsamples that were averaged. The integrating sphere views an area of the leaf 1 cm in diameter, which was positioned to avoid major veins. Reflectance was calculated as $\frac{(\text{Reflected Irradiance} - \text{Dark Irradiance})}{(\text{Standard Irradiance})}$ in S-Plus (Insightful, Inc., Seattle, WA). Vegetative

indices were calculated with the formulas given in table 2. Vegetative indices were selected for their ability to quantify specific pigments. The normalized difference vegetative index (NDVI) has been used in many studies to quantify chlorophyll concentration and photosynthetically active leaf area (Broge and Leblanc 2000). The formula presented here has been adjusted to be more specific to chlorophyll concentration (Gamon and Surfus 1999). The anthocyanin ratio index (ARI) quantifies red pigments such as anthocyanins and betacyanins in the presence of variable levels of chlorophyll (Gitelson et al. 2001, Gitelson, *Personal communication*). The carotenoid reflectance index (CRI) quantifies carotenoid content in leaves (Gitelson et al. 2002).

Name	Description	Formula ^a	Source
Normalized Difference Vegetation Index (NDVI)	Leaf Chlorophyll Content	$\frac{(R_{745:755} - R_{700:710})}{(R_{745:755} + R_{700:710})}$	(Gamon and Surfus 1999)
Anthocyanin Ratio Index (ARI)	Red Leaf Pigment Content	$\frac{1}{R_{550:551}} - \frac{1}{R_{700:701}}$	(Gitelson et al. 2001)
Carotenoid Reflectance Index (CRI)	Leaf Carotenoid Content	$\frac{1}{R_{505:515}} - \frac{1}{R_{535:565}}$	(Gitelson et al. 2002)

^a $R_{745:755}$ is the average reflectance between 745 nm and 755 nm as measured by the ASD FieldSpec FR and the Li-Cor integrating sphere.

Data between regions was combined to simplify presentation of results. Analysis of variance (SAS, Cary, N.C.) was used to compare disease levels for leaf nutrient content and vegetative indices from leaf reflectance. To study the impact of varying levels of nitrogen in healthy plants, leaf nitrogen content was regressed on vegetative indices.

Results

Results for leaf nutrients between the two sampling dates were similar; therefore, the data was combined and presented together (Table 2). Rhizomania resulted in decreased levels of nitrogen and iron, but increased levels of potassium, calcium, manganese, zinc, and magnesium.

	N (%)	Na (ppm)	P (ppm)	K (ppm)	Ca (ppm)	Mn (ppm)	Fe (ppm)	Cu (ppm)	Zn (ppm)	Mg (ppm)
Healthy	4.11a	26089a	2600a	27944b	10200b	84.5b	147.6a	15.2a	34.2b	9944b
Symptomatic	2.95b	24263a	2518a	31294a	15505a	243.7a	106.2b	15.6a	48.1a	12639a

^aData from the two dates and both regions were similar and therefore combined.
^bMeans followed by the same letter within a column are not significantly different ($P>0.05$).

Normalized difference vegetative index (NDVI) values from leaf reflectance were consistently lower in symptomatic leaves than healthy indicating reduced levels of chlorophyll (Table 3). Carotenoid reflectance index (CRI) values were consistently lower in symptomatic leaves than in healthy leaves suggesting lower concentrations of carotenoids (Table 3). In 2000, betacyanins as measured by ARI were not significantly different at the first or second sampling dates, but increased in the healthy by the third and fourth sampling date to become significantly greater than the symptomatic leaves. There were no significant differences in 2001.

Year	Sampling Date	Disease Class	NDVI ^c	CRI	ARI
2000	1	Healthy	0.35a	5.63a	0.22a
		Symptomatic	0.12b	2.58b	0.16a
	2	Healthy	0.32a	5.25a	0.35a
		Symptomatic	0.18b	3.35b	0.21a
	3	Healthy	0.31a	5.07a	0.40a
		Symptomatic	0.18b	3.42b	0.22b
	4	Healthy	0.28a	5.04a	0.58a
		Symptomatic	0.18b	3.67b	0.28b
2001	1	Healthy	0.34a	5.35a	0.39a
		Symptomatic	0.23b	3.97b	0.28a
	2	Healthy	0.35a	4.95a	0.34a
		Symptomatic	0.22b	3.83b	0.21a
	3	Healthy	0.33a	5.22a	0.38a
		Symptomatic	0.25b	4.31b	0.37a

^aData from both regions were similar and therefore combined.
^bMeans within a column and a single sampling date followed by the same letters are not significantly different according to multiple orthogonal contrasts.
^cNDVI = Normalized Difference Vegetative Index, CRI = Carotenoid Ratio Index, ARI = Anthocyanin Ratio Index. See table 1 for formulas.

Leaf nitrogen concentrations regressed on leaf pigments and vegetative indices from leaf reflectance for healthy leaves showed significant relationships for NDVI ($p < 0.0001$) and ARI ($p = 0.04$). While significant, leaf nitrogen concentrations only accounted for a small portion of the total variation with R^2 values of 0.53 for chlorophyll, 0.12 for ARI.

DISCUSSION

Rhizomania resulted in reduced levels of chlorophylls and carotenoids and prevented increases in betacyanins. With in the range of nitrogen levels observed in this study, only a small fraction of the variance could be accounted for by nitrogen content. This would suggest that the foliar symptoms commonly associated with rhizomania couldn't be wholly

attributed to interference with nitrogen assimilation. This matches previous reports. Bürcky and Beiss (1986) reported rhizomania increased invert sugars, calcium, and potassium and decreased amid and amino nitrogen. Müller (1983) reported reduced α -amino nitrogen and increased sodium, potassium, calcium, and sugars other than sucrose in beets infected with rhizomania. Unfortunately, neither of these studies included statistical analyses so it is unclear if these differences are significant. Vianello, et al. (1980) reported a decrease in chlorophyll and carotenoid content in leaves of infected sugar beets. While nitrogen showed significant effects on chlorophyll and betacyanin concentrations, the size of the effect was very small. This work

suggests remote sensing can differentiate between nitrogen and rhizomania at the concentrations encountered in this study.

Acknowledgements

This work was supported in part by the Minnesota North Dakota Sugar Beet Research and Education Board and the Texas Precision Agriculture Legislative Initiative. We would like to thank Dave Major for technical assistance and Resource 21 for loan of the ASD radiometer and integrating sphere.

References

- Broge, N. H. and E. Leblanc (2000). "Comparing prediction power and stability of broadband and hyperspectral vegetation indices for estimation of green leaf area index and canopy chlorophyll density." *Remote Sens. Environ.* 76: 156-172.
- Burcky, K. and U. Beiss (1986). "Damage of sugarbeet caused by *Beet necrotic yellow vein virus* (BNYVV) depending on the degree of soil infestation. II. Nutrient content and juice quality." *Zuckerind.* 111(12): 1111-1118.
- Burcky, K., U. Beiss, et al. (1978). "Tests on the significance of nutrient supply for sugarbeet quality. II. Nitrogen and potassium [chemical quality, physical properties]." *Zuckerind.* 103(3): 190-200.
- Gamon, J. A. and J. S. Surfus (1999). "Assessing leaf pigment content and activity with a reflectometer." *New Phytologist* 143: 105-117.
- Gitelson, A. A. and M. N. Merzlyak (1997). "Remote estimation of chlorophyll content in higher plant leaves." *Int. J. Remote Sens.* 18(12): 2691-2697.
- Gitelson, A. A., M. N. Merzlyak, et al. (2001). "Optical properties and nondestructive estimation of Betacyanin content in plant leaves." *J. Photochem. Photobiol.* 74(1): 38-45.
- Gitelson, A. A., Y. Zur, et al. (2002). "Assessing carotenoid content in plant leaves with reflectance spectroscopy." *J. Photochem. Photobiol.* 75(3): 272-281.
- Heidel, G. B. and C. M. Rush (1994). "Distribution of *Beet necrotic yellow vein virus*, *Beet distortion mosaic virus*, and an unnamed soilborne sugar beet virus in Texas and New Mexico." *Plant Dis.* 78: 603-606.
- Muller, H. J. (1983). "The effect of virus on sugar beet physiology. Also the effect of previous crops on Rhizomania." *Zuckerind.* 108(8): 760-763.
- Rush, C. M. and G. B. Heidel (1995). "Furovirus diseases of sugar beets in the United States." *Plant Dis.* 79(9): 868-875.
- Tuitert, G. and Y. Hofmeester (1994). "Epidemiology of *Beet necrotic yellow vein virus* in sugar beet at different initial inoculum levels in the presence or absence of irrigation." *European Journal of Plant Pathology* 100: 19-53.
- Vianello, A., F. Macri, et al. (1980). "CO₂ fixation and fate of photosynthetic products in leaves of sugar beet affected by Rhizomania." *Phytopathology Z.* 99: 63-69.
- Winter, S. R. (1998). "Sugarbeet response to residual and applied nitrogen in Texas." *Journal of Sugar Beet Research* 35(1-2): 43-62.

TOMBUSVIRUS INFECTION OF LETTUCE IS INFLUENCED BY SOIL SALINITY

William M. Wintermantel and Amy G. Anchieta

USDA-ARS, 1636 East Alisal Street, Salinas, California 93905, USA

Summary

A severe soilborne disease of lettuce has emerged to cause severe losses for lettuce production in the western United States. The disease is caused by a group of tombusviruses, including both *Tomato bushy stunt virus* and the newly described *Lettuce necrotic stunt virus*. Fields with severe infections are usually associated with areas near rivers and areas where flooding has recently occurred. Interestingly, disease severity in infested fields varies considerably from year to year. In order to identify factors contributing to variability in infection, soil analyses were conducted on adjacent fields with similar soil type, but differing for tombusvirus infection. These studies identified soil salinity as the predominant factor differing between diseased and disease-free fields. Subsequent greenhouse studies examined the effect of electrical conductivity levels in the soil on virus infection. Results indicated that elevated electrical conductivity (5.5 dS/cm^3) led to elevated levels of LNSV infection when compared with a lower electrical conductivity (3.2 dS/cm^3), which exhibited very low disease incidence.

Introduction

California produces approximately 75% of the lettuce grown in the United States. A severe dieback disease of lettuce, primarily associated with romaine and leaf lettuce types, has been identified and confirmed in most California and Arizona lettuce production areas. This new disease, known as lettuce dieback, is particularly important to the lettuce industry because of the significant increase in leaf and romaine lettuce acreage in recent years. Losses from lettuce dieback can range from a few plants to complete loss of crop. Two tombusviruses, *Tomato bushy stunt virus* (TBSV) and the closely related and newly described *Lettuce necrotic stunt virus* (LNSV), have been proven to cause this necrosis-inducing disease (Obermeier et al., 2001). These viruses have been consistently identified from symptomatic romaine, red and green leaf, and butterhead varieties, as well as heirloom crisphead varieties from the early 1900s. TBSV and LNSV isolated from infected plants have each been used to reproduce the disease on susceptible lettuce varieties in the greenhouse and in growth chambers (Obermeier et al., 2001). Symptoms include yellowing, necrosis, stunting and death of affected plants. Transmission of LNSV to lettuce does not require a fungal vector, based on studies by our lab in which soil autoclaved for 1 hour in 19 L containers was still able to cause disease under greenhouse assay conditions. Infection rates after autoclaving were approximately 40 percent those of lettuce grown under identical conditions in non-autoclaved soil (Wintermantel, unpublished data). Although not necessary for transmission, studies have not been conducted to determine if fungal vectors can facilitate or increase rates of LNSV transmission to lettuce. Lettuce dieback occurs primarily in low lying areas near rivers, in areas where soil has been dredged from a river or ditch and spread onto fields, on recently flooded land, and land with poor drainage. Interestingly, LNSV-infested fields often exhibit different levels of disease severity from year to year. To determine what soil factors might contribute to this variability, we analyzed soil samples from adjacent lettuce fields with and without lettuce dieback. Results identified soil salt content as a possible factor contributing to the increased disease incidence, and this was supported by subsequent greenhouse experiments.

Materials and Methods

Soil analysis:

Soils were collected from romaine and leaf lettuce fields in which lettuce dieback disease incidence was high, as confirmed by both observation of symptomatic plants and isolation of tombusviruses from symptomatic plants. Soil was also collected from symptom-free romaine or leaf lettuce fields adjacent to the diseased fields. For each set of fields, soil was collected from symptomatic areas of diseased fields, and in a random pattern from non-diseased fields, with soil samples taken from the area around the root zone of lettuce plants. Soil samples were mixed and sent to an independent soil-testing lab for full soil analysis. A total of five sets of adjacent diseased and non-diseased fields were tested.

Greenhouse testing:

Lettuce was directly seeded into two soils: diseased field soil, obtained from a field near Soledad, California exhibiting severe lettuce dieback symptoms and confirmed tombusvirus infection, and soil from the USDA-ARS research plot which did not have any history of lettuce dieback. Lettuce was watered with four different salinity treatments as measured by electrical conductivity (EC). Salinity treatments were 0.5, 1.6, 3.2, and 5.5 dS/cm³. The 0.5 dS/cm³ treatment was a water-only control treatment in which no nutrients or chemicals were added. The 1.6 dS/cm³ treatment contained only a nutrient solution optimized for lettuce (kindly provided by W. Dickinson, Dole Fresh Vegetables, Salinas, CA). Calcium chloride and potassium chloride were added to the 3.2 and 5.5 dS/cm³ treatments to increase EC. Plants received 250 ml of nutrient solution three times per week, and were inoculated at the root zone with either 1 ml of plant sap from LNSV-infected *Nicotiana benthamiana* in phosphate buffer once a week or phosphate buffer without plant sap. At the conclusion of each experiment, soils from each treatment were pooled and soil salinity levels confirmed by testing.

Statistical analysis was performed with the JMPIN program. Growth data was analyzed with ANOVA on data transformed by LOG +1 with nesting, where appropriate, to identify significant differences in plant growth. When comparing the different EC treatments, the control treatment (0.5 dS/cm³) was excluded, to compare only those treatments in which plants received nutrients. This was to avoid bias resulting from the poor growth of the unfertilized plants. The Pearson chi-squared test was performed on count data to determine the independence of the possible factors affecting LNSV infectivity.

Results

In an effort to identify factors responsible for variation in lettuce dieback incidence in fields known to be infested with tombusviruses, we identified adjacent romaine or leaf lettuce fields differing for the presence of lettuce dieback symptoms and tombusvirus infection. Within each set of fields analyzed, both fields had similar physical appearances such as slope, soil texture, and apparent drainage, but differed by whether or not lettuce dieback symptoms were present on susceptible lettuce. Soil samples were collected, a complete soil analysis was conducted, and soil characteristics were compared between diseased and healthy soils. Although several factors were compared, major differences were observed only for EC levels in the soils (Table 1), and to a lesser degree soil nitrate levels (data not shown). Electrical conductivity is a measure of soil salinity. Predominant salts in the Salinas Valley soils compared in this experiment were calcium, magnesium, and potassium salts, with calcium as the most abundant in all soils (data not shown).

Since electrical conductivity was by far the most obvious difference between diseased and healthy soils, greenhouse studies were designed to compare the effect of varying EC on

incidence of lettuce dieback symptom development and tombusvirus infection. Plant growth did not differ significantly between plants grown at any of the three fertilized treatments (1.6, 3.2, and 5.5 dS/cm³), however, unfertilized plants grew significantly less than any of the fertilized plants (0.5 dS/cm³) (Fig. 1). Results were similar for studies conducted with diseased field soil, and for studies conducted in virus free soil in which LNSV was introduced (data not shown). Disease incidence was clearly influenced by EC. Infection was extremely low at 3.2 dS/cm³ (Fig. 2). In contrast, higher and to a lesser extent, lower EC levels resulted in significantly more disease. Disease development was also higher in treatments lacking fertilizer (Fig. 2). It was not clear, however, whether higher disease incidence in the 0.5 dS/cm³ resulted from poor plant nutrition, extremely low EC, or both.

Fig 1.

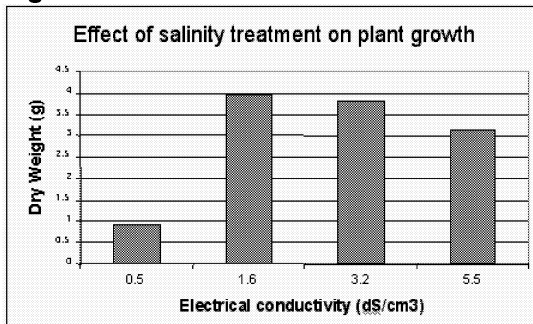
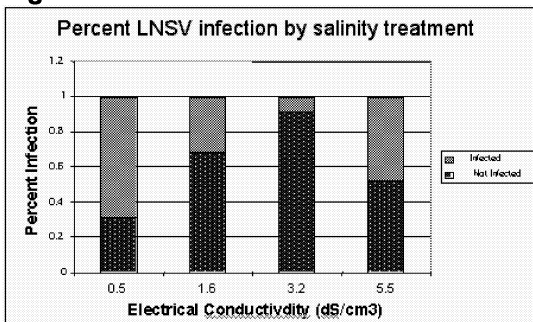

Fig.2.



Discussion

The results of these studies suggest that high EC is a major determining factor as to whether tomosvirus-infested lettuce fields will develop virus infection and lettuce dieback disease. This is consistent with the fact that lettuce dieback is often associated with areas near rivers and recently flooded land. Poorly drained soils often have high EC since leaching does not remove salts from the soil. It is likely that the adjacent fields without disease (Table 1) were also infested with LNSV, but since they had a lower EC, they did not develop disease symptoms. This possibility needs to be explored further in future experiments that would determine if soil from disease free fields adjacent to diseased fields could develop infection if EC levels were increased. Disease levels were also higher when fields did not receive proper nutrition (Fig. 2). It was not clear from these studies, however, whether the increased disease levels in these plants resulted from poor nutrition alone, or if low EC might have contributed. This remains a possibility, since sub-optimal salinity (1.6 dS/cm³) had elevated disease incidence compared with the optimal conditions of 3.2 dS/cm³.

Table 1. Electrical conductivity levels in adjacent LNSV infected and disease free lettuce fields

Soil Source	EC (dS/cm³)
Field 1 Healthy	3.86
Field 1 Disease	7.81
Field 2 Healthy	3.27
Field 2 Disease 1	7.68
Field 2 Disease 2	6.84
Field 3 Healthy	1.43
Field 3 Disease	2.46
Field 4 Healthy	1.83
Field 4 Disease	5.02
Field 5 Healthy	2.41
Field 5 Disease 1	3.70
Field 5 Disease 2	4.10

Reference

Obermeier, C, Sears, J.L., Liu, H.Y., Schlueter, K.O., Ryder, E.J., Duffus, J.E., Koike, S.T., and Wisler, G.C. 2001. Characterization of distinct tomosviruses that cause diseases of lettuce and tomato in the western United States. *Phytopathology* 91(8):797-806.