

**PROCEEDINGS OF THE SIXTH SYMPOSIUM OF THE INTERNATIONAL
WORKING GROUP ON PLANT VIRUSES WITH FUNGAL VECTORS**

Editor: C.M. Rush

**Alma Mater Studiorum Università Di Bologna
Bologna, Italy**

September 5-7, 2005

SPONSORS

Alma Mater Studiorum
Università Di Bologna

Promega Italia

Uniboculture

SESSION CHAIRPERSONS

Virus detection, taxonomy & characterization

Tetsuo Tamada – Session I
Lesley Torrance – Session II

Resistance & Breeding for Resistance

Frank Ordon – Session I
Claude Bragard – Session II

Vector Biology and Detection

Claude Bragard – Session I
Michael J. Adams – Session II

Epidemiology & Disease Management

Charlie Rush – Session I
Thomas Kuhne – Session II

LOCAL ARRANGEMENTS

Victor Vallega
Concepció Rubies-Autonell
Claudio Ratti
Annamaria Pisi

PROGRAM COMMITTEE

Dr. Ueli Merz
Ueli.merz@ipw.agrl.ethz.ch

Dr. Charlie Rush
cm-rush@tamu.edu

Michael J. Adams
mike.adams@bbsrc.ac.uk

PREFACE

The International Working Group on Plant Viruses with Fungal Vectors (IWGPVFFV) was formed in 1988 at Kyoto, Japan, with Dr. Chuji Hiruki as chairperson. Drs. Renate Koenig, John Sherwood, Gail Wisler, and most recently Ueli Merz also have served as Chairperson. Currently, there are approximately 65 members, representing 16 countries. The goal of the working group is to provide a forum to facilitate international collaboration and multidisciplinary research on all aspects of plant viruses with fungal vectors. Members of the group meet every three years to present research on a wide variety of topics including virus taxonomy and characterization, vector biology and ecology, virus-vector interactions, and disease epidemiology and management. The high quality of information presented in an informal setting to an international group with common interests always makes for an enjoyable, professionally rewarding meeting.

Symposia of the working group have been held at the Biologische Bundesanstalt (BBA), Braunschweig, Germany (1990), McGill University, Montréal, Canada (1993), West Park Conference Centre, University of Dundee, Dundee, Scotland (1996), Asilomar Conference Center, Monterey, California (1999), Institute of Plant Sciences, Swiss Federal Institute of Technology (ETH), Zurich, Switzerland (2002), and Alma Mater Studiorum, Università Di Bologna, Bologna, Italy (2005). This volume serves as a record of material presented at this most recent meeting. It is hoped that the information in this Proceedings will be useful to members of the IWGPVFFV and all those interested in viruses with fungal vectors.

The IWGPVFFV is a totally volunteer group and success of its meetings is in large part a result of the hard work and contributions of the local organizing committee and sponsors. The 2005 meeting in Bologna was no exception, and the hospitality and good times will be remembered fondly. Those most responsible for the success of the recent meeting are listed on the next page. The names and e-mail addresses of the current program committee are also listed. Please contact a member of the program committee if you wish to be included in any future mailings of the IWGPVFFV. The next symposium is scheduled to be held in 2008 at the Federal Centre for Breeding Research on Cultivated Plants, Quedlinburg, Germany.

Charlie Rush
Proceedings Editor



6th IWGPV FV
Symposium
5-7 September 2005 - Bologna



Contents

	Page
Preface	
Acknowledgements	
Virus detection, taxonomy and characterization	
A taxonomic review of the fungally-transmitted viruses. Michael J. Adams	1
Distribution of various types of <i>Beet necrotic yellow vein virus</i> in Europe and abroad. R. Koenig, F. Pferdmeiges, G. Büttner, W. Herrenschwand, G. Deml and M. Vallermann	5
Analysis of the vascular movement of <i>Beet necrotic yellow vein virus</i> in <i>Nicotiana benthamiana</i> and <i>Beta vulgaris</i> Spp. <i>Maritime</i> using GFP-expressing viruses. Tetsuo Tamada, H. Kondo, I. B. Andika, M. D. Rahim and S. Bouzoubaa	10
Comparisons of RNA silencing suppressors encoded by two Benyviruses, <i>Beet necrotic yellow vein virus</i> and <i>Burdock mottle virus</i> . Hideki Kondo, I. B. Andika, E. Kurokawa, S. Bouzoubaa and T. Tamada	14
Molecular analysis of the UK <i>Beet necrotic yellow vein virus</i> (BNYVV) containing RNA5. Lisa Ward, C. McGrath, H. Stubbley, G. Budge and N. Boonham	18
Analysis of the subgenomic RNAs and the small ORFs of <i>Beet black scorch virus</i> . X. Yuan, Y. Cao, D. Xi, L. Gou, C. Han, D. Li and Jialin Yu	23
Role of <i>potato mop-top virus</i> triple gene block proteins in intercellular movement and replication. Lesley Torrance, G. Cowan, S. Haupt, T. Gillespie and A. Ziegler	27
Formation of virus-like particles from <i>Beet necrotic yellow vein virus</i> coat protein expressed by a cactus potexvirus-based vector construct. Renate Koenig, D. E. Lesemann, S. Loss and W. Burgermeister	31
Resistance to <i>Mirafiori lettuce big-vein virus</i> in transgenic lettuce carrying the protein gene of <i>Lettuce big-vein associated virus</i> . Yoichi Kawazu, R. Fijuyama, K. Sugiyama and T. Sasaya	35
The new French barley-infecting furovirus is closely related to the Japanese strain of <i>Soilborne wheat mosaic virus</i> . Djabbar Hariri, Michel Meyer and Maud Rivard	40

Freesia leaf necrosis: A new ophiovirus involved? A. M. Vaira, V. Torok, G. P. Accotto, S. Rapetti, M. Vecchiati, V. Mesenga, J.J. Vetten and R. G. Milne	44
Characteristics of differential host species for distinguishing <i>Beet necrotic yellow vein virus</i> isolates of different pathogenicity. Tetsuo Tamada and Kazuyuki Maruyama	47
Involvement of <i>Beet necrotic yellow vein virus</i> RNA 4 in symptom expression in <i>Nicotiana benthamiana</i> . Mahammad Danial Rahim, Ida Bagus Andika, Cheng Gui Han, Kideki Kondo and Tetsuo Tamada	51
Monoclonal antibodies for differentiation between <i>Soilborne Cereal Mosaic Virus</i> and <i>Soilborne wheat mosaic virus</i> . Frank Rabenstein, Heidrun Mühlheim, Ute Kastirr and Thomas Kühne	55
Typical Russian isolate of <i>Tobacco necrosis virus</i> . R. V. Gnotova and V. F. Tolkach	59
A molecular comparison of <i>Soilborne cereal mosaic virus</i> isolates originating from Germany and France. R. Goetz and W. Huth	63
The reassortment of genomic RNAs of <i>Wheat yellow mosaic virus</i> (WYMV) Pathotype I and II in a resistant and susceptible cultivar. Yasuo Ohto and Jun-ichi Sakai	67
Resistance Mechanisms and Breeding for Resistance	
The RNA silencing-mediated resistance to <i>Beet necrotic yellow vein virus</i> : differences of the silencing activity in leaves and roots. Ida Bagus Andika, H. Kondo and T. Tamada	71
Marker based strategies in breeding for bymovirus resistance in barley. Frank Ordon, K. Werner, A. Habekuß, I. Krämer, D. Perovic, N. Stein, Graner and W. Friedt	75
Translocation resistance – most effective type of resistance to furoviruses of wheat. Winfried Huth, D. E. Lesemann and R. Goetz	80
Breakdown of <i>Rz1</i> in individual plants of rhizomania tolerant cultivars. Charlie M. Rush, K. Steddom, D. Jones, and R. Acosta-Leal	83
Reaction of 111 cultivars <i>Triticum durum</i> Desf. of various origins to <i>Soilborne cereal mosaic virus</i> . Victor Vallega, C. Rubies Autonell, C. Ratti, M. Maccaferri, R. Tuberosa and M. C. Sangueneti	87

Identification of genes differentially expressed in sugar beet roots in response to challenge by *Polymyxa graminis*. 91
Graham R. D. McGrann, L. D. Martin, Michael J. C. Asher,
M. J. Adams and E. S. Mutaso-Göttgens

Reaction of cultivars of *Triticum aestivum* L. to *Wheat spindle streak mosaic virus* and to *Soilborne cereal mosaic virus*. 96
C. Rubies Autonell, V. Vallega and C. Ratti

Selection of durum and common wheat accessions for resistance to furoviruses under controlled environmental conditions. 99
Ute Kastirr, Edgar Müller, Peter Römer, Ralf Schachschneider
and Thilo Hamman

Vector Biology and Detection

The use of PCR methods for *Polymyxa graminis* to study intraspecific variation, phylogeny and inoculum levels. 103
Elaine Ward, J. Motterham, K. Kanyuka and M. J. Adams

Occurrence and significance of the temperate ribotypes of *Polymyxa graminis*. 107
Madeleine Smith, E. Ward, J. Walsh and M. J. Adams

Sorosphaera viticola Nom. Prov., newly discovered plasmodiophorid, a potential vector for grape vine viruses? 111
Martin Kirchmair, S. Neuhauser, C. Scholz and L. Huber

Molecular methods for the detection of *Polymyxa graminis* F. s.p. *temperata* and *P. Graminis* F. s.p. *tepida* in association with Bymo- and furoviruses. 116
Cèline Vaïanopoulos, C. Bragard, H. Maraite and A. Legrève

Epidemiology and Disease Management

UK field investigation of *Beet necrotic yellow vein virus* (BNYVV) containing RNA5. 121
Giles Budge, L. Ward and C. M. Henry

Soil treatment with carbofuran mitigates *Peanut clump virus* disease incidence and is toxic to the vector *Polymyxa graminis* 125
Philippe Delfosse, F. Nguyen, A. M. Paridaens and A. Legrève

The role and climate and alternative hosts in the epidemiology of rhizomania. 129
Anne Legrève, J-F. Schmit, C. Bragard and H. Maraite

Survey for *Beet necrotic yellow vein virus* and *Polymyxa betae* Keskin in Marvdasht, Fars Province of Iran. 133
Mohammad Reza Moosavi and N. Nekooiezadeh

Epidemiological aspects of soil-borne viruses of wheat, triticale and rye in Germany. Ute Kastirr, F. Rabenstein and T. Kühne	137
Epidemiological significance of seed transmission of <i>Peanut clump virus</i> to pearl millet. Gaetan Otto, B. Dieryck, P. De Hertog, X. Sauvenier, P. Delfosse and A. Bragard	142
A survey on the incidences of <i>Beet yellow necrotic yellow vein virus</i> (BNYVV), <i>Beet soilborne virus</i> (BSBV) and their vector, <i>Polymyxa betae</i> Keskin in sugar beet fields in northern and central parts of Turkey. Nazli D. Kutluk Yilmaz, Semra Saracoglu, M. Ali Sevik and Miray Arli-Sokmen	146
Study of <i>Beet Soilborne Virus</i> and <i>Beet Virus Q</i> host range and distribution in infected plants. I.Homa, M. Zouhar and P. Rysanek	151
Detection of <i>Beet necrotic yellow vein virus</i> in Lithuania. Elana Jackeviciene, Juozas Staniulis, Irena Zitikaite, Loreta Tuluntyte, Lina Jankuviene and Ilona Vascilo	156
The occurrence and distribution of sugar beet rhizomania in Croatia. Edyta Đermic, Bogdan Cvjetkovic and C. Rubies Autonell	161
Incidence of sugar beet soilborne viruses in sugar beet growing countries. C. Ratti, L. Bianchi, R. Resca, M. DeBiaggi, V. A. Harju, C. M. Henry, E. Jackeviciene, B. Cvjetkovic and C. Rubies Autonell	165

A TAXONOMIC REVIEW OF THE FUNGALLY-TRANSMITTED VIRUSES

Michael J Adams

Wheat Pathogenesis Programme, Plant Pathogen Interactions Division, Rothamsted Research, Harpenden, Herts AL5 2JQ, UK
mike.adams@bbsrc.ac.uk

Summary

Taxonomic issues amongst the four broad categories of plant viruses with “fungal” vectors are discussed. *Olipidium* species transmit some small monopartite ssRNA(+) viruses that are carried on the outside of the zoospores and resting spores. The viruses are all members of the family *Tombusviridae*. *Olipidium* species also transmit some ssRNA viruses with divided negative sense genomes that are members of the unassigned genera *Ophiovirus* and *Varicosavirus*. These viruses are internally-borne. Plasmodiophorids (*Polymyxa* and *Spongospora* spp.) are only known to transmit viruses internally and these are all ssRNA(+) viruses with divided genomes. Some have rod-shaped virions (genera *Benyvirus*, *Furovirus*, *Pecluvirus*, *Pomovirus*) while others have filamentous particles (genus *Bymovirus*, family *Potyviridae*).

Introduction

For the purposes of this review, plant viruses with “fungal” vectors will be considered in four broad taxonomic categories.

ssRNA(+) isometric viruses transmitted by *Olipidium*

Some members of the genera *Aureusvirus*, *Carmovirus*, *Necrovirus* and *Tombusvirus* (family *Tombusviridae*) are carried on the outside of *Olipidium* zoospores and resting spores. These externally-borne viruses have isometric particles that can be adsorbed onto the zoospore surface. The fungally-transmitted species are not a separate phylogenetic group, but are scattered amongst other species in the family that are apparently not transmitted in the same way (although it is possible that the true vector has been overlooked). Viruses previously described as the A and D serotypes of Tobacco necrosis virus (TNV) are now classified as separate species. They are fairly closely related in their coat proteins but occur on quite distinct phylogenetic branches within the family if the other genes are used. This makes their classification difficult and may necessitate reconsideration of the status of the genus *Necrovirus* (Stuart et al., 2004). The satellite virus associated with TNV does not have formal taxonomic status but there are considerable sequence variations amongst published isolates.

ssRNA(-) viruses transmitted by *Olipidium*

For many years, the agents of lettuce big-vein and tobacco stunt diseases have been believed to be internally borne within *Olipidium brassicae*. The viruses initially proved difficult to isolate and study but it has now been shown that they have divided negative sense RNA genomes. Big-vein disease is caused by *Mirafiori lettuce virus*, in the genus *Ophiovirus*, whose members have filamentous particles and 3 or 4 genome components. There is a proposal to create a family *Ophioviridae* for this genus (Martin et al., 2005). *Lettuce big-vein associated virus* (LBVaV), which has rod-shaped virions and a bipartite genome, is allocated to the genus *Varicosavirus*. This genus has also not yet been assigned to a family but its polymerase shows a clear relationship to those of plant-infecting species in the family *Rhabdoviridae*, all of which have an undivided genome (Sasaya et al., 2002;

Fig. 1). Recent sequence data for the coat protein of Tobacco stunt virus shows that it is a strain of LBVaV rather than a separate species (Sasaya et al., 2005).

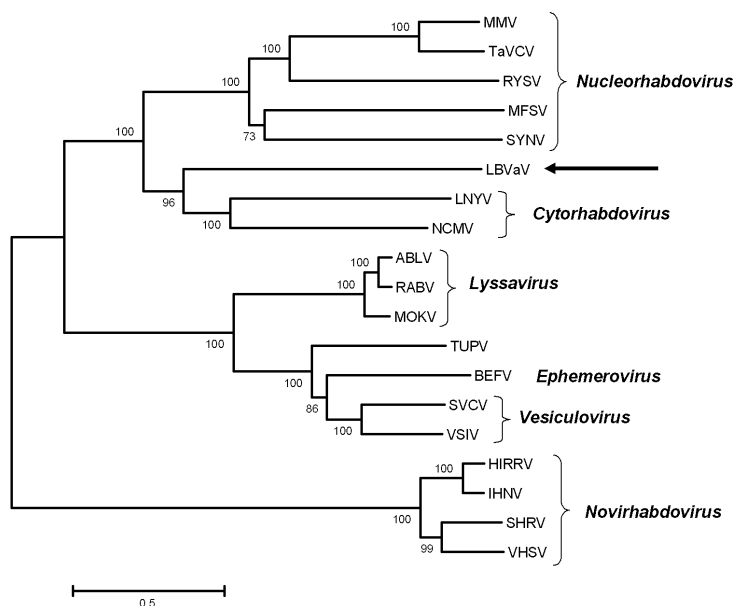

Fig. 1. Phylogenetic (neighbour-joining) tree of the polymerase amino acid sequences of members of the family *Rhabdoviridae* with Lettuce big-vein associated virus (genus *Varicosavirus*) arrowed

ssRNA(+) rod-shaped viruses transmitted by plasmodiophorids

Rod-shaped viruses transmitted by *Polymyxa* or *Spongospora* species were initially all described as furoviruses (*fungally-transmitted rod-shaped viruses*) but when genome sequences became available, they were re-classified into four genera, based on genomic organisation (Table 1). None of these genera has yet been assigned to a family.

Table 1. Characteristics of the genera of rod-shaped viruses transmitted by plasmodiophorids

Genus	No. of RNA components	Type of movement protein*	Presence of coat protein readthrough	Polyadenylation of genomic RNA
<i>Benyvirus</i>	4 or 5	TGB	Yes	Yes
<i>Furovirus</i>	2	'30K'	Yes	No
<i>Pecluvirus</i>	2	TGB	No	No
<i>Pomovirus</i>	3	TGB	Yes	No

* TGB, triple gene block; '30K', single protein of the '30K' superfamily

There are substantial sequence differences between wheat-infecting furovirus isolates from different geographical regions. Isolates from Europe and China have only 60-70% nt identity to one another and to the USA isolates of *Soil-borne wheat mosaic virus* (SBWMV). The European isolates have therefore been named *Soil-borne cereal mosaic virus* and those from China as *Chinese wheat mosaic virus* (Diao et al., 1999). Isolates from Japan appear to form a fourth group (Fig. 2). However, because these isolates are similar in host range and symptoms and because at least some of their genome components are able to complement one another, it has been argued that they should be regarded as isolates of a single species (Shirako et al., 2000; Miyanishi et al., 2002). However, it is not unknown for RNA components of different species to complement one another

(e.g. Salanki et al., 1997) and the substantial sequence differences across the entire genome suggest that biological differences may well be expected. This will have to be resolved by further investigation.

The genera *Benyvirus*, *Furovirus*, *Pecluvirus* and *Pomovirus* do not form a single phylogenetic

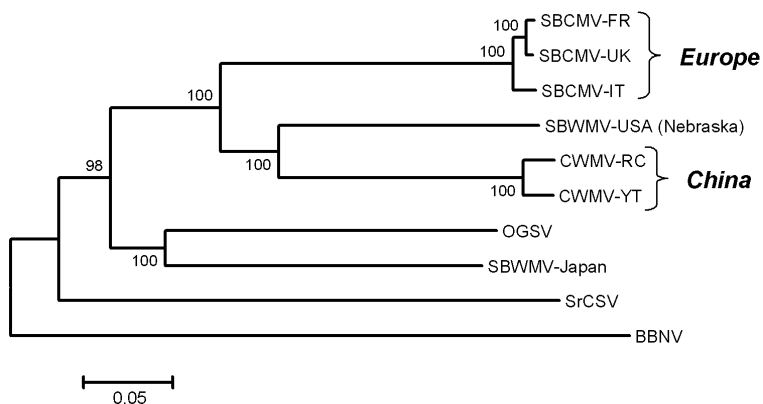

Fig. 2. Phylogenetic (neighbour-joining) tree of the polymerase nucleotide sequences of members of the genus *Furovirus* with *Broad bean necrosis virus* (BBNV, genus *Pomovirus*) as outgroup.

group. Analyses of the polymerase (RdRp) domains led Koonin & Dolja (1993) to place *Beet necrotic yellow vein virus* (BNYVV; genus *Benyvirus*) in one supergroup (with the alphaviruses) and SBWMV (*Furovirus*) in a different one (with the tobamoviruses and others). An analysis with the much larger number of sequences now available supports this conclusion and places the genera *Furovirus*, *Pecluvirus* and *Pomovirus* with *Hordeivirus*, *Tobamovirus* and *Tobravirus* in a single well-supported group (Fig. 3). Amongst the other genes, the small cysteine-rich proteins of *Furovirus*, *Hordeivirus*, *Pecluvirus* and *Tobravirus* are related but those of *Benyvirus* and *Pomovirus* do not align well with them (results not shown). The triple gene block proteins of genera *Pecluvirus*, *Pomovirus* and *Hordeivirus* form a natural grouping and again differ from BNYVV (Morozov & Solovyev, 2003). It might be possible to create a family of rod-shaped viruses excluding *Benyvirus*, but it has been questioned whether this would have much practical value.

ssRNA(+) filamentous viruses of the family *Potyviridae* transmitted by *plasmodiophorids*

The filamentous viruses of cereals transmitted by *Polymyxa graminis* are all members of the genus *Bymovirus*. These resemble other members of the family *Potyviridae* in some respects but have two

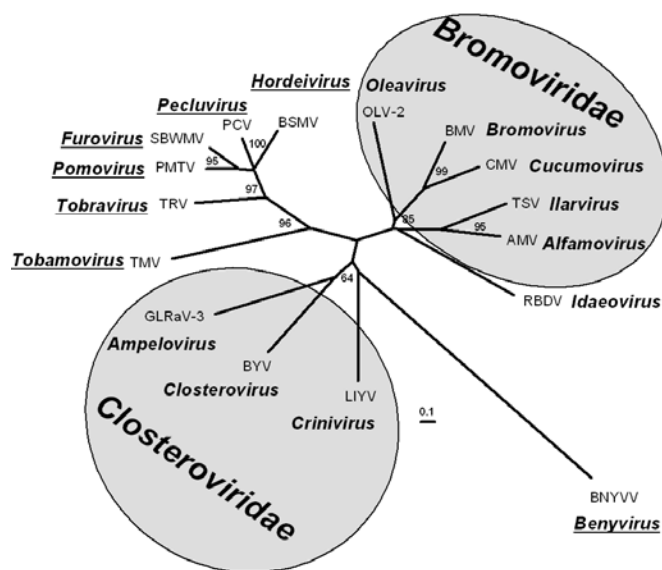

Fig. 3. Phylogenetic (neighbour-joining) tree of the RdRp amino acid sequences of members of selected viruses showing the relationships between the various rod-shaped virus genera (underlined)

genomic RNAs. The two viruses of barley (*Barley yellow mosaic virus* and *Barley mild mosaic virus*) are very different from one another at the molecular level (~50% nt identity), whereas the two that infect wheat (*Wheat spindle streak mosaic virus* and *Wheat yellow mosaic virus*) are much more closely related (~70% nt identity). There are no major current taxonomic issues in the genus, but a proposed order Picornavirales might include the family *Potyviridae*.

General issues in plant virus taxonomy

The correct use of formal species names (with initial capital letter and in italics) continues to cause some confusion. The rules only apply to the formal scientific name of the species, which is an abstract concept. Virus isolates (the entities studied) do not have to conform to any rules. The use of a “binomial” nomenclature for species names (e.g. *Beet necrotic yellow vein benyvirus*) has been canvassed. This format is more popular amongst plant virologists than in some other disciplines, but it has been left to individual study groups to propose the change if they wish.

References

- Diao, A., Chen, J., Gitton, F., Antoniw, J.F., Mullins, J., Hall, A.M. & Adams, M.J. (1999) Sequences of European wheat mosaic virus and oat golden stripe virus and genome analysis of the genus *Furovirus*. *Virology* **261**, 331-339.
- Koonin, E.V. and Dolja, V.V. (1993) Evolution and taxonomy of positive-strand RNA viruses: implications of comparative analysis of amino acid sequences. *Crit. Rev. Biochem. Mol. Biol.* **28**, 375-430.
- Martin, S., Lopez, C., Garcia, M.L., Naum-Ongania, G., Grau, O., Flores, R., Moreno, P. and Guerri, J. (2005) The complete nucleotide sequence of a Spanish isolate of Citrus psorosis virus: comparative analysis with other ophioviruses. *Arch. Virol.* **150**, 167-176.
- Miyaniishi, M., Roh, S.H., Yamamiya, A., Ohsato, S. and Shirako, Y. (2002) Reassortment between genetically distinct Japanese and US strains of Soil-borne wheat mosaic virus: RNA1 from a Japanese strain and RNA2 from a US strain make a pseudorecombinant virus. *Arch. Virol.* **147**, 1141-1153.
- Morozov, S.Y. and Solovyev, A.G. (2003) Triple gene block: modular design of a multifunctional machine for plant virus movement. *J. Gen. Virol.* **84**, 1351-1366.
- Salanki, K., Carrere, I., Jacquemond, M., Balazs, E. and Tepfer, M. (1997). Biological properties of pseudorecombinant and recombinant strains created with cucumber mosaic virus and tomato aspermy virus. *J. Virol.* **71**, 3597-3602.
- Sasaya, T., Ishikawa, K. and Koganezawa, H. (2002) The nucleotide sequence of RNA1 of Lettuce big-vein virus, genus *Varicosavirus*, reveals its relation to nonsegmented negative-strand RNA viruses. *Virology* **297**, 289-297.
- Sasaya, T., Ishikawa, K., Kuwata, S. and Koganezawa, H. (2005) Molecular analysis of coat protein coding region of tobacco stunt virus shows that it is a strain of Lettuce big-vein virus in the genus *Varicosavirus*. *Arch. Virol.* **150**, 1013-1021.
- Shirako, Y., Suzuki, N. and French, R.C. (2000) Similarity and divergence among viruses in the genus *Furovirus*. *Virology* **270**, 201-207.
- Stuart, G., Moffett, K. and Bozarth, R.F. (2004) A whole genome perspective on the phylogeny of the plant virus family *Tombusviridae*. *Arch. Virol.* **149**, 1595-1610.

DISTRIBUTION OF VARIOUS TYPES OF BEET NECROTIC YELLOW VEIN VIRUS IN EUROPE AND ABROAD

R. Koenig^{1,2}, F. Pferdenges², G. Büttner, W. Herrenschwand³, G. Deml¹ and M. Varrelmann

¹Biologische Bundesanstalt für Land-und Forstwirtschaft, Institut für Pflanzenvirologie, Mikrobiologie und biologische Sicherheit, D-38104 Braunschweig, Germany.

²Institut für Zuckerrübenforschung, D-37079 Göttingen, Germany

³Schweizerische Fachstelle für Zuckerrübenanbau, Ch-3270 Aarberg, Switzerland

Summary

Beet necrotic yellow vein virus (BNYVV)-infected sugar beet roots were obtained from various parts in Europe and abroad. Two genome regions on RNA 2 and a third one on RNA 3 were amplified by means of PCR and sequenced. The sequences of the previously recognized A, B and P types were found to be highly conserved even in geographically widely separated regions of Europe. The c. 40 samples from all major sugar beet growing areas in Germany contained B type BNYVV. As in previous investigations, A type BNYVV was found in southern, eastern and extreme western Europe. The sequences of the virus from the Imperial valley (USA) were closely related to those of the European A types which differ in several positions from a published Japanese A type sequence. As noticed by several other authors considerable variation exists in amino acids 67–70 of the RNA 3-encoded P25, especially in BNYVV A types. B types in Germany almost exclusively contained a P25 with a AYHR tetrad. Only in small areas in southern Germany and Switzerland a deviating B type was found in which P25 had a AHHR tetrad in positions 67-70. In fields this B type did not seem to have an altered pathogenicity. P25 in the A types from the Imperial valley and a severely affected area in Spain contained a P25 with unusual VLHG and VCHG tetrads, respectively, in positions 67-70.

Introduction

Breeding for resistance has been the most successful means of controlling the BNYVV-caused sugar beet rhizomania. Recently it has been reported that the resistance based on the widely used *Rz1* gene may be overcome by new resistance-breaking BNYVV strains in the USA (Liu *et al.*, 2005; Rush *et al.*, 2005) and possibly also in Spain and elsewhere (J. Ayala, personal communication). In order to recognize possible changes in the BNYVV genome which might enable the virus to overcome the established resistances, molecular typing is now done by researchers in several institutions. In the present study we report on the results of such studies with BNYVV sources mainly from Germany and some other European countries and from a few places outside of Europe (Kazakhstan, Iran, USA).

Materials and methods

Immunocapture RT PCR (Koenig *et al.*, 1995) was used to amplify three different genome regions of BNYVV (Fig. 1) from the sugar beet root samples received. The first region on RNA 2 comprises the 3' part of the coding sequence for the coat protein readthrough protein, necessary for efficient *Polymyxa* transmission, and the 5' part of the

first of the three triple gene block (TGB) genes which encode the viral movement proteins. The second region, also on RNA 2, comprises the third TGB gene and the gene for P14, a possible suppressor of posttranscriptional gene silencing (Dunoyer *et al.*, 2002). The third region - on RNA 3 - comprises the coding region for P25, which is mainly responsible for the rhizomania symptoms and the yield losses caused by BNYYV (Koenig *et al.*, 1989; Tamada *et al.*, 1999). The following primer pairs were used: 5'-ggtgagttgaagggcttata-3' (sense) / 5'-ttttaccccgttcattta-3' (antisense) for region 1; 5'-tctggggtagcgtagta-3' (sense) / 5'-gaacaaccaataggaggc-3' (antisense) for region 2 and 5'-tcggaatatacaaggtttaaag-3' (sense) / 5'-gtcccaaccagatcaacaa-3' (antisense) for region 3, respectively. The PCR products were sequenced by a commercial company (MWG-Biotech Ebersberg/Germany) and the sequences were analyzed by the UWGCG software version 8.

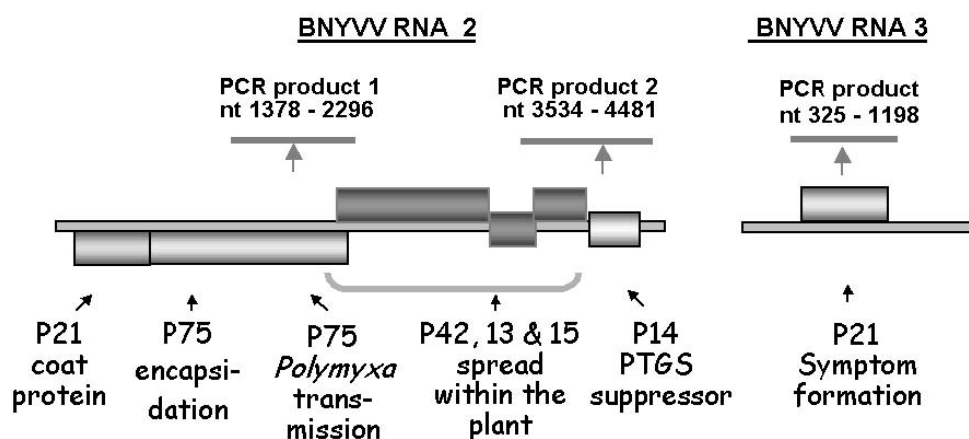

Fig. 1. Genome regions of BNYYV amplified and sequenced in this study

Results and Discussion

BNYYV RNA 2-derived PCR products. – About 40 samples from all major sugar beet growing areas in Germany (Fig. 2) and about the same number of samples from other countries, i.e. Sweden, The Netherlands, France, Switzerland, Spain, Italy, Greece, the Czech Republic, Slovakia, Kazakhstan, Iran and the USA (Imperial valley) were analyzed. As in our previous studies (Koenig *et al.*, 1995; Koenig and Lennefors, 2000) A, B and P types of BNYYV were clearly distinguished. In the past few years we have found in Germany only B type BNYYV whereas in previous studies done more than a decade ago we had found occasionally also A type BNYYV in this country (e.g. Koenig *et al.*, 1995). At that time we had anticipated that the A type would gradually spread in Germany, but this has apparently not happened. This may indicate that an area which has become infested once by one of the major types of BNYYV may be more or less protected against invasion by another BNYYV type - possibly due to a competition between different *Polymyxa* strains. The B type was found to be widespread also in Switzerland, France and the Czech Republic, whereas the A type was prevalent in the other countries listed above. As noticed by us previously the sequences of A types and B types were strongly conserved even in rather widely separated geographic locations (Koenig and Lennefors, 2000). The percentages of nucleotide differences in the two RNA 2-derived PCR products ranged from 0 to 0.2 % (at the most) among the A types and from 0 to 0.5% (at the most) among the B types. The sequences of the virus from

the Imperial valley closely resembled the European A types differing from them by less than 0.25 %. The sequences of the European A types and the A type from the Imperial valley, however, differed in more than 1.3% of their nucleotides from those of a Japanese A type analyzed by Saito *et al.* (1996). The sequences of the European A types differed from those of the European B types by almost 5% in the two RNA 2-derived PCR products analyzed here.

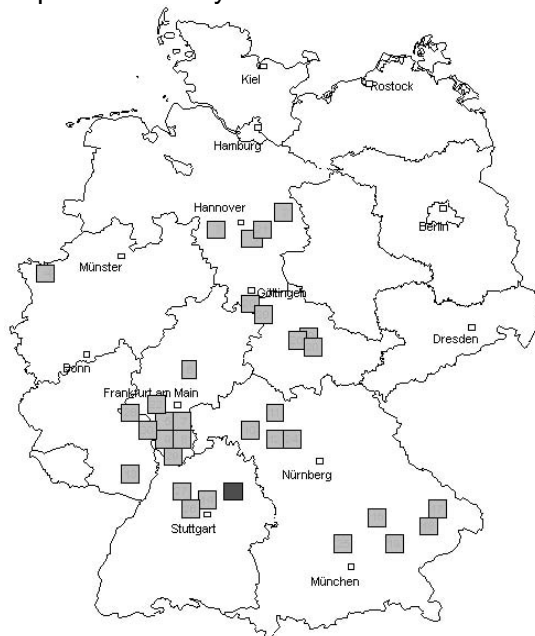

Fig. 2. Origin of sugarbeet samples from various regions of Germany. ■ 'classical' BNYVV B type in which a AYHR tetrad is present in position 67-70 of P25, ■ deviating B type having an AHHR tetrad in position 67-70 of P25.

BNYVV RNA 3-derived PCR products. - The nucleotide sequences of the RNA 3-derived PCR products also revealed pronounced differences between A and B types. The most striking feature in the RNA 3-derived PCR products, especially in those of the A types, was the pronounced nucleotide sequence variability in the coding regions for amino acids 67-70 of P25. In BNYVV A types from different locations altogether eight different variants were found for this amino acid tetrad, i.e. ALHG (Sweden, the Netherlands, France, Italy, Greece), AHHG (Switzerland, Italy, Iran), ACHG (Italy, Spain), AFHG (Czech Republic), AYHG (Czech Republic, Slovakia), SYHG (Kazakhstan, France - Pithiviers), VCHG (Spain) and VLHG (USA - Imperial valley). In the B types only two variants of this tetrad were found. The vast majority of the B types had a P25 with an AYHR amino acid tetrad in positions 67-70. However, a deviating B type with an AHHR tetrad was found in small areas in southern Germany (Fig. 2) and Switzerland. In Germany this variant must have been established for at least 10 years as an analysis of old samples indicated. There were no indications that the fields infested with this deviating B type were affected more severely or less severely by rizomania than fields infested with the common B type. The great variability of the amino acid tetrad in positions 67-70 of P25 has been noticed also by others (Tamada *et al.*, 2002; Meunier *et al.*, 2002; Lemaire *et al.*, 2003; Ratti *et al.*, 2005). Chiba *et al.* (2002) have presented evidence that P25 acts as a pathogenicity factor in susceptible lines of *Beta maritima* and as a avirulence factor in resistant ones and that these functions are influenced by the amino acid present in position 68 of P25. With mutants of infectious RNA 3 cDNA clones we are presently trying to find out whether the amino acid tetrad in positions 67-70 of P25 has an influence on the aggressiveness of the virus in different sugarbeet genotypes.

Acknowledgements

We gratefully acknowledge the skillful technical assistance of Mrs. Petra Lüddecke and the financial support given by the Arbeitsgemeinschaft industrieller Forschungsvereinigungen (AiF Grant 14163 N/2, GFP BR42/04).

References

- Chiba, S., Miyanishi, M., Kondo, H. & Tamada, T. (2002). Single amino acid changes in the P25 protein gene of *Beet necrotic yellow vein virus* are involved in resistance responses in *Beta vulgaris* ssp. *maritima*. *Proceedings of the Fifth Symposium of the International Working Group on Plant Viruses with Fungal Vectors*, Zurich, Switzerland, July 22-25, 2002, p. 5-8.
- Koenig, R. & Burgermeister, W. (1989). Mechanical inoculation of sugarbeet roots with isolates of beet necrotic yellow vein virus having different RNA composition. *J. Phytopath.* **124**, 249-255.
- Koenig, R., Lüddecke, P. & Haeblerlé, A.M. (1995). Detection of beet necrotic yellow vein virus strains, variants and mixed infections by examining single-strand conformation polymorphisms of immunocapture RT-PCR products. *J. Gen. Virol.* **76**, 2051-2055.
- Koenig, R. & Lennefors, B. L. (2000). Molecular analyses of European A, B and P type sources of Beet necrotic yellow vein virus and detection of the rare P type in Kazakhstan. *Arch. Virol* **145**, 1561-1570.
- Lemaire, O., Beuve, M., Weber, C., Schirmer, A., Link, D., Meunier, A., Bragard, C. & Gilmer, D. (2003). Etiology and molecular epidemiology of a severe rhizomania disease occurring in confined locations in Europe: Hypothesis for the implication of the RNA3 and/or RNA5 of *Beet necrotic yellow vein virus* (BNYVV)-P pathotype. *Proc. 66th IIRB Congress*, February 2003, San Antonio, Texas (USA), p. 303-318.
- Liu, H.-Y., Sears, J. L. & Lewellen, R. T. (2005). Occurrence of resistance-breaking Beet necrotic yellow vein virus of sugar beet. *Plant Dis.* **89**, 464-468.
- Meunier, A., Schmit, J.-F. & Bragard, C. (2002). Sequences analysis of Belgian BNYVV and development of simultaneous detection of soil-borne sugar-beet viruses by RT PCR. *Proceedings of the Fifth Symposium of the International Working Group on Plant Viruses with Fungal Vectors*, Zurich, Switzerland, July 22-25, 2002, p. 9-12.
- Ratti, C., Resca, R., Lanzoni, C. & Rubies Autonell, C. (2005). Amino acid changes in the 25 protein of Beet necrotic yellow vein virus. *Sixth Symposium of the International Working Group on Plant Viruses with Fungal Vectors, Bologna – Italy, September 5-7, 2005, Book of Abstracts*, p 63.
- Rush, C. M., Steddom, K., Jones, D., Timmons, B. & Acosta-Leal, R. (2005). Breakdown of Rz1 in individual plants of Rhizomania tolerant cultivars. *Sixth Symposium of the International Working Group on Plant Viruses with Fungal Vectors, Bologna – Italy, September 5-7, 2005, Book of Abstracts*, p 28.
- Saito, M., Kiguchi, T., Kusume, T. & Tamada, T. (1996). Complete nucleotide sequence of the Japanese isolate S of beet necrotic yellow vein virus RNA and comparison with European isolates. *Arch. Virol* **141**, 2163-2175.
- Tamada, T., Uchino, H., Kusume, T. & Saito, M. (1999). RNA 3 deletion mutants of *Beet necrotic yellow vein virus* do not cause Rizomania disease in sugar beets. *Phytopathology* **89**, 1000-1006.

Tamada, T., Miyanishi, M., Kondo, H., Chiba, S. & Han, C.G. (2002). Pathogenicity and molecular variability of *Beet necrotic yellow vein virus* isolates from Europe, Japan, China, and the United States. *Proceedings of the Fifth Symposium of the International Working Group on Plant Viruses with Fungal Vectors*, Zurich, Switzerland, July 22-25, 2002, p. 13-16.

ANALYSIS OF THE VASCULAR MOVEMENT OF *BET* NECROTIC YELLOW VEIN VIRUS IN *NICOTIANA BENTHAMIANA* AND *BETA VULGARIS* SPP. *MARITIMA* M8 USING A GFP-EXPRESSING VIRUS.

Tetsuo Tamada¹, Hideki Kondo¹, Ida Bagus Andika¹, Muhammad Danial Rahim¹, and Salah Bouzoubaa²

¹Research Institute for Bioresources, Okayama University, Kurashiki, 710-0046, Japan.

²Institut de Biologie Moleculaire des Plantes, CNRS, 12 rue du General Zimmer, 67084 Strasbourg, France

Summary

Beet necrotic yellow vein virus (BNYVV) usually produces local lesions on inoculated leaves of sugar beet plants (*Beta vulgaris* spp. *vulgaris*), but rarely moves systemically in this host. The virus can, however, readily move from inoculated to upper, noninoculated leaves of *Nicotiana benthamiana*, *B. vulgaris* spp. *maritima* M8 and *B. macrocarpa* plants. Here, we examined the pattern of the vascular movement of BNYVV in different host plants using a green fluorescent protein (GFP)-expressing recombinant virus. The GFP gene was introduced into the coat protein readthrough domain of BNYVV RNA2. Only RNA1 and RNA2 are required for systemic movement in *N. benthamiana*. The GFP-virus was shown to move from inoculated leaf down the stem toward the roots via the phloem. The virus accumulated at high level in roots. In *B. vulgaris* spp. *maritima* M8 and *B. macrocarpa*, on the other hand, RNA3 is required for vascular movement. The patterns of vascular movement of the virus in these different host plants were described.

Introduction

Systemic transport through the vascular system is a crucial step in plant virus infection. Most plant viruses are thought to move systemically through the phloem in parallel with photoassimilate transport (Hull, 2002). Phloem transport includes the loading (entry) of the virus into the phloem at source tissues, its circulation in the transport phloem and its unloading (exit) from the phloem at the sink tissues.

Beet necrotic yellow vein virus (BNYVV) is transmitted to sugar beet roots by the soil-born fungus *Polymyxa betae*. In general, the virus is restricted in roots of sugar beet and very rarely moves to aerial parts of plants showing yellow vein symptoms in leaves (Tamada, 1989). BNYVV RNA1 and RNA2 encode "house-keeping" genes involved in replication, assembly and cell-to-cell movement, whereas RNA3, RNA4 and RNA5 are associated with vector-mediated infection and disease development in sugar beet roots. RNA3 has major effects on rhizomania symptoms. RNA4 is for efficient transmission by the fungus. RNA5 is associated with disease development and found only in limited areas. BNYVV forms local lesions on inoculated leaves of *Chenopodium quinoa* and *Tetragonia expansa* plants, but does not move systemically in these hosts. The virus can, however, readily move from inoculated to upper, noninoculated leaves of *Beta macrocarpa*, *Spinacia oleracea*, and *Nicotiana benthamiana* plants (Tamada *et al.*, 1989; Lauber *et al.*, 1988; Andika *et al.*, 2005). In this case, RNA3 is essential for vascular movement in *B. macrocarpa*, although it is not required in *S. oleracea* and *N. benthamiana*. We have selected an additional RNA3-dependent systemic host, *B. vulgaris* spp. *maritima* M8 (*B. maritima* M8), which is more susceptible to BNYVV than *B. macrocarpa*. Here, we have examined the patterns of vascular movement of the virus in three different hosts *N. benthamiana*, *B. maritima* M8 and *B. macrocarpa* using a GFP-expressing virus.

Materials and methods

Plants and growth conditions

T. expansa plants were used for virus propagation (Tamada *et al.*, 1989). *N. benthamiana*, *B. maritima* M8 and *B. macrocarpa* plants were used for systemic hosts. After seeds were germinated, all seedlings were transplanted into special test tubes (24 mm wide and 120 mm long with a draining hole) filled with quartz sand and were grown in a growth cabinet at 24 C with a 16-h light.

GFP-expressing virus and inoculation

Two constructs, pB2-RT-GFP2 (RT2) and pB2-RT-GFP3 (RT3), expressing the green fluorescent protein (GFP), were used (Erhardt *et al.*, 2001; Valentin *et al.*, 2005). They were derived from pB2-14, which contains the wild-type BNYVV RNA2 cDNA clones into pBluescript Clontech). The GFP sequence was amplified by the PCR using primers designated to introduce *Accl* sites at the both ends of the GFP sequence. In RT2, the resulting fragment was digested with *Accl* and inserted between *Accl*1415 and *Accl*1826 of pB2-14. In RT3, the GFP sequence fragment was inserted in frame into the *Accl*1415 site of pB2-14. Capped RNA transcripts produced by *in vitro* transcription of the constructs were mixed with the wild-type BNYVV RNA1 transcript. The mixture was inoculated to leaves of *T. expansa*. In this experiment, RT3 was used (BNYVV-GFP), unless otherwise stated.

Preparation of tissue samples for GFP detection

Leaf, petioles, stems and roots of plants inoculated with BNYVV-GFP were sampled. Transverse sections of the plant material were prepared by hand with a razor blade. The GFP fluorescence was observed with a fluorescence microscope (Zeiss Axioskop) equipped with a 10 filter (450 to 490 nm excitation filter, 510 nm dichroic mirror, 515 to 565 nm emission filter).

Results

Systemic movement of BNYVV-GFP in N. benthamiana plants

When BNYVV-GFP was inoculated to leaves of *N. benthamiana* seedlings, slight distorting symptoms appeared on upper, developing leaves at 12 days postinoculation (dpi). To monitor the pattern of vascular movement of BNYVV, we examined the presence of BNYVV-GFP in each plant part (leaves, stems, petioles and roots) for virus infection at daily intervals for 15 days (three to five plants observed per days). In the inoculated leaf, BNYVV-GFP infection was first observed at 2 dpi by the appearance of fluorescent spots, which increased in the number and size in the following days.

In the early step of systemic infection (6 to 8 dpi), GFP expression was first observed in only small parts in the roots at 6 dpi. Next, BNYVV-GFP was detected in vascular and cortical cells in the stem above inoculated leaf at 7 to 8 dpi. In the same time point, small GFP signals were sometimes observed in vascular systems of the stem below the inoculated leaf (Fig.1F). GFP expression was not

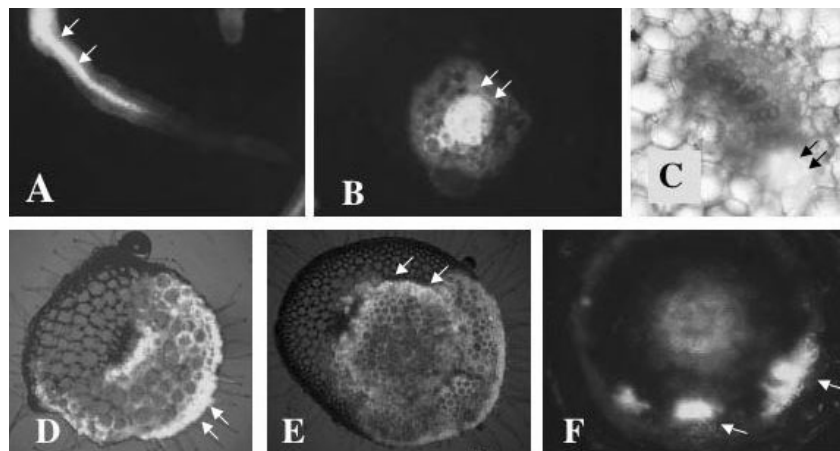

Fig. 1. BNYVV-GFP infection in *N. benthamiana* at 9 to 12 dpi. A and B, Lateral root. C, Vascular tissue in the leaf petiole. D, Leaf petiole. E, Stem above the inoculated leaf. F, Stem below the inoculated leaf. Arrows indicate GFP fluorescence signals.

observed in shoot apex and in petiole of the inoculated leaf. In the second step (9 to 12 dpi) when systemic symptoms began to appear, GFP fluorescence was detected in most parts of lateral roots, (Fig. 1A and B), where BNYVV-GFP infection moved in vascular systems and in cortical cells (Fig. 1D), but never seen in root tips. In the stem below the inoculated leaf, BNYVV-GFP appeared to move in phloem cells to cortical cells and to xylem elements. However, successive transverse sections showed that GFP was discontinuous in vascular systems of the stem and petiole. In the stem above inoculated leaf, much stronger GFP signals were found in epidermal and cortical cells and in vascular systems. At this time point, systemic spread of BNYVV-GFP into the lamina and veins of the developing leaf was also detected. In the petiole of this infected leaf, BNYVV-GFP appeared to be confined to phloem cells. In the later step of infection (13 to 15 dpi), BNYVV-GFP was found to spread in lamina and veins of developing leaves, stems and roots, although the distribution of GFP expression was limited. In the petioles and stems, BNYVV-GFP appeared to spread from phloem cells to xylem elements that consist of vessels and xylem parenchyma cells.

Systemic movement of BNYVV-GFP in B. maritima M8 plants

BNYVV RNA3 is essential for systemic movement in some Beta species (Tamada, 1989), and therefore *B. maritima* M8 seedlings were coinoculated with BNYVV-GFP and the RNA3 transcript. No differences in symptom expression and virus movement were found between two constructs RT2 and RT3. In the inoculated leaf, BNYVV-GFP infection was first observed at 2 dpi in clusters of several epidermal cells, as described in *N. benthamiana*. By 5 dpi, chlorotic spots appeared in the inoculated leaf, which corresponded to clusters of larger numbers of cells displaying the GFP fluorescence. Systemic yellow mosaic and leaf curling symptoms appeared in developing shoots at 8 to 12 days, only when young seedlings (2 to 3 true-leaf stages) were inoculated. In the seedlings inoculated at the later stages, symptom development was delayed. Thus, the frequency of symptom infection is greatly dependent on the plant stage. The systemically infected plants were severely stunted and finally died. The presence of GFP expression at different tissues was monitored by 20 dpi, as described in previous experiments.

BNYVV-GFP was first detected in leaf lamina and in vascular systems in stem (hypocotyl) and roots at 8 to 12 dpi, when symptoms just began to appear. Those tissues of seedlings without symptoms (before symptom appearance) did not show any GFP fluorescence. In shoots showing symptoms (upward movement), BNYVV-GFP was observed in leaf lamina as small rounds or long and short shapes along the veins. In the following days, BNYVV-GFP spread much more in cortical and epidermal cells than in vascular systems. This suggests that BNYVV-GFP infection toward the shoot apex is due to cell-to-cell movement through cortical

cells. In downward movement, GFP fluorescence was first detected in vascular cells of the stem and main root at 8 to 10 dpi. GFP expression was continuous in vascular systems in those tissues. In the following days (14 to 18 dpi), BNYVV-GFP was still limited in phloem systems in the stem and main root, but in lateral roots, GFP fluorescence was detected in cortical cells, although strong fluorescent signals were always detected in vascular bundles. In the stems, GFP fluorescence was detected into xylem elements occasionally. In *B. macrocarpa* plants, systemic yellow mosaic symptoms appeared in upper, noninoculated leaves at 15 to 23 dpi. The pattern of vascular movement in this plant species was similar to that in *B. maritima* M8 plant, although the frequency of systemic infection was lower. In some cases, only one yellow spot developed in an upper leaf, in which BNYVV-GFP was detected in leaf lamina, and small GFP foci were detected in cells of the stem and roots of the same plant occasionally.

Discussion

In this study, we demonstrate the pattern of systemic infection (cell-to-cell movement and long distance movement) of BNYVV using a GFP-expressing virus. The expression of the GFP gene from the P75 coat protein readthrough protein in BNYVV RNA2 established that the GFP gene was efficiently expressed and stably maintained with the BNYVV genome. From time course experiments using BNYVV-GFP, it was found that BNYVV has different pathways to systemic movement in two hosts, *N. benthamiana* and *B. maritima* (similar to *B. macrocarpa*). In *N. benthamiana*, the virus moves first in the roots, then to the upper stems. Once the virus enters the phloem systems, its movement can be very rapid. Virus can move easily in vascular bundles to cortical cells. In *B. maritima* M8 plants, however, the virus moves first into shoots, then to the roots via phloem systems. In shoots, virus spread is likely due to cell-to-cell movement between cortical and epidermal cells rather than to long distance movement through vascular systems. Toward roots, the virus moves through vascular bundles (vascular-dependent movement). Interestingly, the distribution of BNYVV-GFP in stems and main roots indicated that BNYVV was restricted into vascular bundles, suggesting that the virus has difficulty in moving from vascular systems into cortical cells. However, virus movement between those cells in lateral roots is easy. It is also noteworthy that BNYVV-GFP moves into xylem elements from phloem cells in two hosts *N. benthamiana* and *B. maritima* M8.

References

- Andika, I. B., Kondo, H. and Tamada, T. 2005. Evidence that RNA silencing-mediated resistance to *Beet necrotic yellow vein virus* is less effective in roots than in leaves. *Mol. Plant-Microb. Interact.* **18**, 194-204.
- Erhardt, M., Dunoyer, P., Guilley, H., Richards, K., Jonard, G. and Bouzoubaa, S. 2001. *Beet necrotic yellow vein virus* particles localize to mitochondria during infection. *Virology* **286**, 256-262.
- Hull, R. (2002). *Matthews Plant Virology*. 4th ed. Academic Press, San Diego Ca, U.S.A.
- Tamada, T. 1999. Benyviruses. In: *Encyclopedia of Virology*. Second Edition. R. G. Webster and A. Granoff, eds. Academic Press, London. p. 154-160.
- Tamada, T., Shirako, Y., Abe, H., Saito, M., Kiguchi, T. and Harada, T. 1989. Production and pathogenicity of beet necrotic yellow vein virus with different numbers of RNA components. *J. Gen. Virol.* **70**, 3399-3409.
- Valentin, C., Dunoyer, P., Vetter, G., Schalk, C., Dietrich, A. and Bouzoubaa, S. 2005. Molecular basis for mitochondrial localization of viral particles during *Beet necrotic yellow virus* infection. *J. Virol.* **79**, 9991-10002.

COMPARISONS OF RNA SILENCING SUPPRESSORS ENCODED BY TWO BENY- VIRUSES, *BEET NECROTIC YELLOW VEIN VIRUS* AND *BURDOCK MOTTLE VIRUS*

Hideki Kondo¹, Ida Bagus Andika¹, Emi Kurokawa¹, Salah Bouzoubaa², and Tetsuo Tamada¹

¹Research Institute for Bioresources, Okayama University, Kurashiki 710-0046, JAPAN

²Institut de Biologie Moleculaire des Plantes (IBMP), 12 Rue du General Zimmer, 67084 Strasbourg Cedex, France

Summary

We demonstrated that the P14 cysteine-rich protein (CRP) of *Beet necrotic yellow vein virus* (BNYVV) and the P13 CRP of Burdock mottle virus (BdMV) displayed RNA silencing suppressor activity by agrobacterium-mediated patch co-expression assay. These two proteins showed a weaker RNA silencing suppression than HC-Pro, a well-known suppressor from potyvirus, and had a little effect on green fluorescent protein (GFP)-specific siRNA accumulation. Expression of the P14 and P13 from a recombinant *Potato virus X* (PVX) vector had a dramatic effect on PVX symptoms development in *Nicotiana benthamiana*, converting its mild mosaic symptoms into an extensive necrosis, however, this pathogenicity was not due to enhanced virus accumulation. These results showed that the CRPs encoded by benyvirus function as RNA silencing suppressor and may also involved in virus pathogenicity.

Introduction

In plants, post-transcriptional gene silencing (PTGS) is part of a defense mechanism against virus and viroid infection. Several plant viruses have been shown to encode proteins which can counteract PTGS (Roth *et al.*, 2004; Moissiard and Voinnet, 2004). Different PTGS-suppressor proteins appear to act at different points in the PTGS pathway (Roth *et al.*, 2004; Moissiard and Voinnet, 2004). Further characterization of additional silencing suppressors will certainly be of value in further dissecting the RNA silencing pathway.

Viruses belonging to the genera *Furo*-, *Hordei*-, *Tobra*-, *Peclu*-, *Beny*- and *Carlavirus* encode small cysteine-rich proteins (CRPs) near the 3' ends of their genomes. The benyvirus *Beet necrotic yellow vein virus* (BNYVV) is a soilborne fungus-transmitted plant virus with rigid rod-shaped virions encapsidating four or five plus-sense RNA genome segments (Tamada, 1999). The BNYVV CRP (P14) was implicated in the *cis*-accumulation of BNYVV RNA2 and the *trans*-accumulation of its CP (Hehn *et al.*, 1995). The other benyviruses, *Beet soil-borne mosaic virus* (BSBMV) and Burdock mottle virus (BdMV), also carry a small, 3'-terminal gene encoding a CRP (Hirano *et al.*, 1999; Rush, 2003).

This study was undertaken to compare the CRPs encoded by two benyviruses, BNYVV and BdMV, in virus pathogenicity and RNA silencing suppressor activity,.

Materials and Methods

To obtain pBin-P14 and pBin-P13, the CRP ORFs were amplified by PCR of the BNYVV (O11) and BdMV cDNA clones, respectively, and inserted between the *Xba* I and *Bam* HI restriction sites of pBin61 binary Ti vector. pBin-GFP, pBin-P19, pBin-2b and pBin-HCPro were obtained from D. C. Baulcombe. PVX-P13 and PVX-P14 were constructed by inserting PCR fragments between the *Cla* I and *Sal* I restriction sites of pgR106 binary vector (from D. C. B.).

Agrobacterium tumefaciens strain GV3101 or C58C1 (from D. C. B.) was used for the agroinfiltration assay. Bacteria carrying pBin-based constructs were infiltrated into *N.*

benthamiana 16C leaves. Co-inoculation of two cultures was done by mixing at a 50:50 ratio before inoculation. The toothpick inoculum contained *A. tumefaciens* with either pGR106-CRP constructs or a pGR106 vector without an insert (PVX-vector control). Inoculated plants were grown at 23°C (16 h of light).

Extraction of low and high molecular weight RNAs and gel blot analyses were performed as described previously (Andika *et al.*, 2005). The blots were hybridized with a digoxigenin (DIG)-labelled, negative-sense T7 transcript of the GFP gene. Western blot analysis was also carried out as previously described by Andika *et al.* (2005).

The amino acid sequences were analyzed with GENETYX-MAC software package (Software Development Co. Ltd.).

Results and Discussion

Silencing suppressor activity of benyvirus CRPs.

To test the silencing-suppression activity of CRP from benyviruses, the binary constructs expressing P14 of BNYVV and P13 of BdmV were created. Observations of leaves under a long-wave UV light revealed bright GFP fluorescence in leaf areas infiltrated with pBin-GFP + pBin-P14 or pBin-GFP + pBin-P13 (Fig. 1A, P14, P13), but not with pBin-GFP plus the empty vector pBin61 (Fig. 1A, pBin61). A vector containing nontranslatable version of the P13 or P14 cistrons in the infiltration mixture showed no remarkable enhancement of GFP fluorescence. The level of enhanced GFP fluorescence in leaves infiltrated with a mixture of GFP and HCPro of potyvirus (Fig. 1A, HCPro) was very high. In contrast, the mixture of GFP and 2b protein of CMV GFP fluorescence was very faint.

Northern blot analyses verified that the increased fluorescence resulted from elevated levels of the GFP-specific mRNA (Fig. 1B). The GFP transcript was abundant in the RNA of patches that had received pBin-GFP + pBin-HCPro (Fig. 1B, HCPro). The level of elevated GFP mRNA in pBin-GFP + pBin-P13 and pBin-GFP + pBin-P14 were significantly higher than pBin-GFP + pBin61 (Fig. 1B, P13, P14, Bin61)., however, pBin-GFP + pBin-P13 was slightly higher than pBin-GFP + pBin-P14.

The P14 and P13 genes had a little effect on systemic silencing and GFP-specific small interfering RNA (siRNA) that guides sequence-specific degradation. These results suggested that the benyvirus CRPs showed a weaker RNA silencing suppression than HC-Pro. The relative intensities of the GFP fluorescence in the patches suggested that P14 was a slightly less efficient suppressor than the P13.

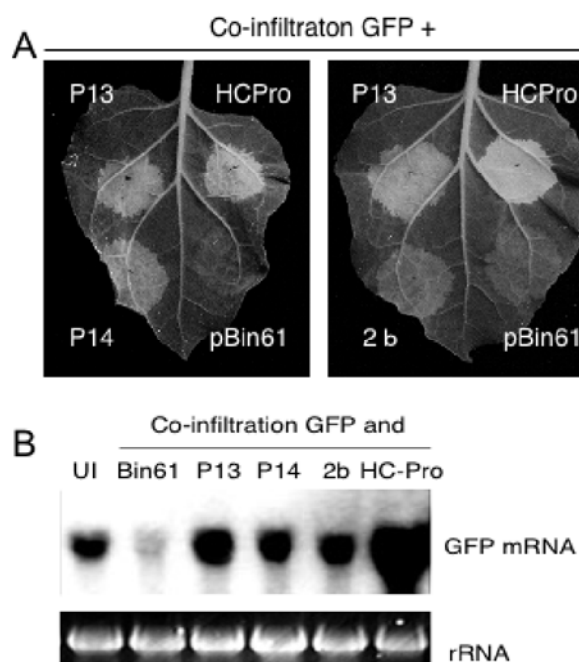

Fig. 1. Suppression of local GFP silencing by benyvirus CRPs. GFP-transgenic *N. benthamiana* (16c) was agroinfiltrated with the pBin-GFP gene and pBin-P13, pBin-P14, pBin-HCPro, pBin-2b or pBin61. (A) GFP fluorescence visualized under UV-light irradiation. The infiltrated plant was kept at 23°C for 5 days. (B) Northern analysis of GFP mRNA in infiltrated zones. UI: uninfiltrated 16c leaves. The lower panel shows ethidium bromide (EtBr) staining of the same samples.

Pathogenicity of a PVX chimera expressing benyvirus CRPs

To determine whether expression of CRPs can enhance the pathogenicity, the CRP coding regions were inserted into the PVX-based vector to produce PVX-P14 and PVX-P13, respectively. Inoculation of *N. benthamiana* with PVX lacking any insert resulted in a systemic, chlorotic mottle or mosaic. In contrast, both PVX-P14 and PVX-P13 induced severe systemic symptoms. The appearance of viral symptoms in the upper leaves was accompanied by necrosis in the petioles and veins and then in mesophyll tissue. Necrosis of the upper leaves and rapid death of infected plants resulted. The symptom expression PVX-P13 was slightly faster than those of P14.

To compare levels of PVX, PVX-P14 and PVX-P13 accumulation in systemically infected leaves, viral RNA accumulation was analyzed by northern blot (Fig. 1B). The results showed that similar levels of genomic RNA accumulation were detected in the upper leaves of PVX, PVX-P14 and PVX-P13 inoculated plants. Western blotting with PVX-specific antiserum revealed similar levels of viral CP for PVX, PVX-P14 and PVX-P13. Thus, the enhanced virulence of PVX expressing of P13 or P14 was not due to enhanced virus accumulation.

Amino acid comparison of the benyvirus CRPs

Amino acid sequence comparisons of the benyvirus CRPs with other CRPs from furo-, hordei-, tobra-, peclu-, carlaviruses showed that these small CRPs were unrelated. CRP is the most divergent protein among the benyviruses. When the amino acid sequences were compared, the similarities between the CRP of BNYVV and BdMV (19.7%) were much lower than those between CRP of BNYVV and BSBMV (38.3%).

Interestingly, multiple alignments reveal that all proteins, in particular, share a region of four cysteines (Fig. 2). This conserved cysteine residues may comprised putative zinc-binding motif. In fact, the ability of the P14 protein of BNYVV to bind Zn(II) was already demonstrated (Niesbach-Klosgen *et al.*, 1990). This conserved sequence of the benyvirus CRPs has no relationship to that of furo-, hordei-, tobra- and pecluvirus CRPs (Cys-Gly...Cys-Gly-X-X-His) (Te *et al.*, 2005). In the peclu- and the hordeiviruses, CRPs contain a peroxisomal targeting signal (Ser-Lys-Leu) at the C-terminus (Dunoyer *et al.*, 2002). This signal is also not present in the CRPs of benyviruses.

Our results showed that the CRPs encoded by benyvirus function as weak-RNA silencing suppressor and are also involved in virus pathogenicity. In other plant

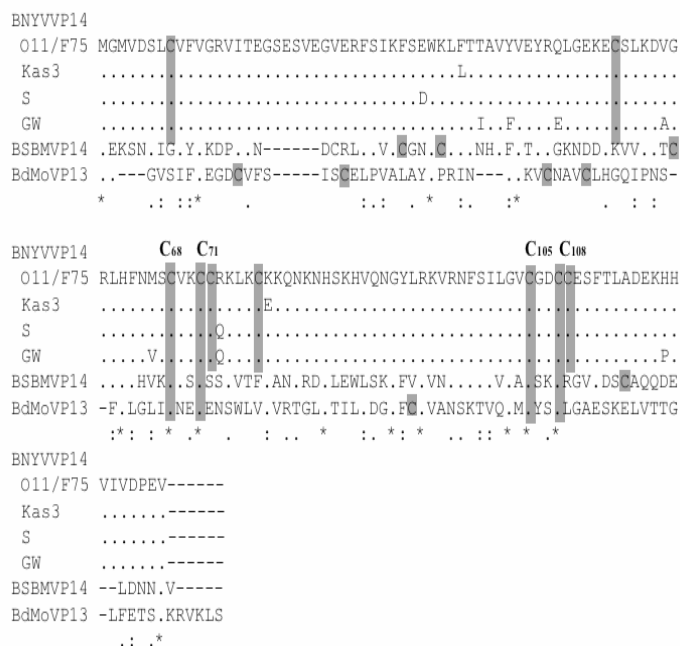

Fig. 2. Amino acid sequence alignment of the cysteine-rich proteins encoded by benyviruses. Cysteine residues were shown in gray background. Asterisks are used to indicate conserved amino acids. The sequence data were collected from DDBJ under the following accession numbers: BNYVV-S D84411, BNYVV-Kas3 AF197556, BNYVV-F75 AF197547, BNYVV-GW X04197 and BSBMV AF061869. The sequences of BNYVV-O11 and BdMV were unpublished.

viral CRPs, for example, *Barley stripe mosaic virus* gamma b, *Peanut clump virus* 15K, *Tobacco rattle virus* 16K and *Soilborne wheat mosaic virus* 19K proteins have been identified as both silencing suppressor proteins and pathogenicity factors (Yelina *et al.*, 2002; Dunoyer *et al.*, 2002; Reavy *et al.*, 2004; Te *et al.*, 2005). The direct evidence for silencing suppressor activity of the CRPs from distantly related viruses suggests that they are members of a widespread new group of silencing-suppressor proteins.

We are grateful to Dr. David C. Baulcombe for providing the *N. benthamiana* line 16c seeds, *Agrobacterium* strains and plasmid constructs. We thank Soutaro Chiba, Dr. Mashamichi Nishiguchi and Dr. Nobuhiro Suzuki for technical advice and discussions. We also thank Chisa Hirokado for technical assistance.

References

- Andika, I. B., Kondo, H., and Tamada, T. (2005). Evidence that RNA silencing-mediated resistance to *Beet necrotic yellow vein virus* is less effective in roots than in leaves., *Mol Plant Microbe Interact.* **18**, 194-204.
- Dunoyer, P., Pfeffer, S., Fritsch, C., Hemmer, O., Voinnet, O., and Richards, K. E. (2002). Identification, subcellular localization and some properties of a cysteine-rich suppressor of gene silencing encoded by peanut clump virus. *Plant J.* **29**, 555-567.
- Hehn, A., Bouzoubaa, S., Bate, N., Twell, D., Marbach, J., Richards, K., Guilley, H., and Jonard, G. (1995). The small cysteine-rich protein P14 of beet necrotic yellow vein virus regulates accumulation of RNA 2 in cis and coat protein in trans. *Virology* **210**, 73-81.
- Hirano, S., Kondo, H., Maeda, T., and Tamada, T. (1999). Burdock mottle virus has a high genome similarity to beet necrotic yellow vein virus. *Proceeding Symp. 4th Int. Work. Group on Plant Viruses with Fungal Vector.* pp.33-36.
- Moissiard, G. and Voinnet, O. (2004). Viral suppression of RNA silencing in plants. *Mol. Plant Pathol.* **5**, 71-82.
- Niesbach-Klosgen, U., Guilley, H., Jonard, G., and Richards K. (1990). Immunodetection in vivo of beet necrotic yellow vein virus-encoded proteins. *Virology* **178**, 52-61.
- Reavy, B., Dawson, S., Canto, T., and MacFarlane, S. A. (2004). Heterologous expression of plant virus genes that suppress post-transcriptional gene silencing results in suppression of RNA interference in *Drosophila* cells. *BMC Biotechnol.* **4**, 18.
- Roth, BM, Pruss, GJ, Vance, VB, (2004). Plant viral suppressors of RNA silencing. *Virus Res.* **102**, 97-108.
- Rush, C. M. (2003). Ecology and epidemiology of benyviruses and plasmodiophorid vectors . *Annu. Rev. Phytopathol.* **41**, 567–592.
- Tamada, T. (1999). Benyviruses. *In: Encyclopedia of Virology.* Second Edition. R. G. Webster and A. Granoff, eds. Academic Press, London. pp. 154-160.
- Te, J., Melcher, U., Howard, A., and Verchot-Lubicz, J. (2005). *Soilborne wheat mosaic virus* (SBWMV) 19K protein belongs to a class of cysteine rich proteins that suppress RNA silencing. *Viol. J.* **2**, 18.
- Yelina, N. E., Savenkov, E. I., Solovyev, A. G., Morozov, S. Yu. & Valkonen, J. P. T. (2002). Long-distance movement, virulence, and RNA silencing suppression controlled by a single protein in hordeid and potyviruses: complementary functions between virus families. *J. Virol.* **76**, 12981–12991.

MOLECULAR ANALYSIS OF THE UK *BEET NECROTIC YELLOW VEIN VIRUS* (BNYVV) CONTAINING RNA5

Lisa Ward, Catherine McGrath, Heather Stubbley, Giles Budge and Neil Boonham

Central Science Laboratory, Sand Hutton, York, YO41 1LZ

Summary

Rhizomania disease of sugar beet is caused by *Beet necrotic yellow vein virus* (BNYVV). Molecular analysis of the virus has revealed the existence of different strains of the virus, A, B and P; the 'P' type strain, which contains an additional genomic RNA (RNA5), is generally believed to be more aggressive than the A and B types. In the UK, A and B types of the virus predominate, but in 2001 the P type was detected for the first time at two outbreak sites. RNA species 2, 3, 4 and 5 were sequenced from one UK P type BNYVV isolate over three seasons. Sequence data from each RNA species was aligned with other BNYVV sequences from the NCBI database. The molecular relatedness between the UK P type and other P types occurring in different parts of the world was determined.

Introduction

Rhizomania disease of sugar beet is caused by Beet necrotic yellow vein virus (BNYVV). The virus has a world-wide distribution and molecular analysis has revealed the existence of different strains of the virus, A, B and P. The 'P' type strain, which contains an additional genomic RNA (RNA5), is generally believed to be more aggressive than the A and B types. P type isolates have been reported in Japan, China (Miyanishi *et al.*, 1999), Kazakhstan, France (Koenig *et al.*, 1997) and more recently in the UK (Harju *et al.*, 2002). The aim of the work presented was to sequence the different RNA species for the UK P type and to determine the molecular relatedness of this to other BNYVV P, A and B types from around the world.

Material and Methods

The BNYVV P pathotype RNA samples used in this study were obtained from infected bait plants grown in soil from the P type infected site in Norwich, Norfolk. BNYVV A and B type RNA was obtained either from bait plants grown in infected soil from the UK or from freeze dried cultures from the CSL culture collection. Primers were successfully designed to amplify regions of the RNA species 2,3,4 and 5 using GENOSYS oligomail software. The primers were designed using the following sequences RNA2 – Triple gene block (TGB) accession AF197556, RNA3 accession AF197545, RNA4 accession AF197546 and RNA5 accession AJ439620. The primers were optimized for use in RT PCR. BNYVV RT PCR products were purified for sequencing using a QIAquick[®] PCR purification Kit (Qiagen). Sequencing was carried out at the Nucleic Acid Department of the Technology Facility of the University of York. The sequences generated were aligned using DNASTAR MegAlign software. Sequences for BNYVV RNA 2, 3, 4 and 5 from other isolates were obtained from a NCBI search. For each RNA species, all sequences available were then aligned using the DNASTAR MegAlign software programme. Cluster trees for each BNYVV RNA species were produced using Treecon, a program, which calculates, distances using Jukes-Cantor method (all changes equally likely), and the neighbour-joining method with 1000 bootstrap re-sampling and a 75% boot strap value. The trees were rooted with sequence from *Beet soil-borne mosaic virus* (BSBMV) (AF280541). The sequence sizes used in the analysis were 408nt (RNA2), 362nt (RNA3), 521nt (RNA4) and 457nt (RNA5).

Results

RNA2

Analysis of the cluster tree for BNYVV RNA2 shows groupings for A, B and P sequences. The RNA2 sequence for the UK Pathotype from years 2002 and 2003 was the same for all isolates. The UK P Pathotype also clusters with an isolate from Japan suggesting that the UK and Japanese RNA2 species are very closely related. RNA2 from the P types from France and Kazakhstan also appear closely related to that of the UK and Japanese isolates, but bootstrap analysis supports two sub-clusters for the French and Kazakhstan P types. Although there are separate clusters for the A and P types, the branches from which these clusters arise are not significantly different. This would suggest that the P type RNA2 is closely related to the A type RNA2. The bootstrap value on the branch separating the B pathotype is 100%, showing that the nucleotide sequence of the B Pathotype is significantly different. (Fig. 1)

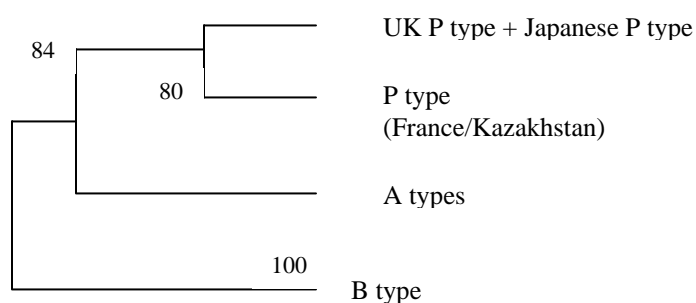

Fig. 1 A simplified cluster tree for RNA 2 sequences showing groupings of P, A and B types of BNYVV. The tree was rooted with *Beet soil-borne virus* (not shown). The values indicate the number of times out of 1000 that this grouping occurred after bootstrapping the data.

RNA3

Analysis of the cluster tree for BNYVV RNA3 shows three main groupings of P with A types, P with B types and UK P types. The P with A type cluster is well supported with bootstrap values over 75%. In addition, a further 2 sub-clusters are supported for a group of UK A types and a group of other European A types with French and Kazakhstan P types. The B types from the UK and Germany cluster with P types from France, however, bootstrapping analysis shows that these B and P types sub-cluster separately and that the sub-clusters are significantly different. The branch from which these sub-clusters arise, however, is not well supported. In view of this, the B with P types and the UK P types could swap places in the tree (Fig 2).

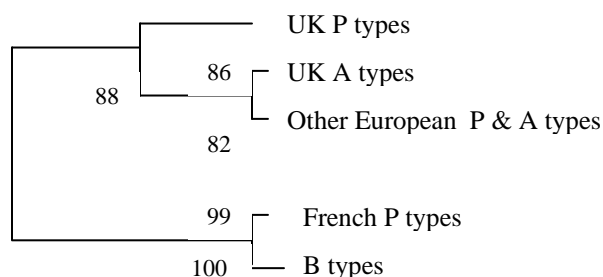

Fig. 2 A simplified cluster tree for RNA3 sequences showing groupings of P, A and B types of BNYVV. The tree was rooted with *Beet soil-borne virus* (not shown). The values indicate the number of times out of 1000 that this grouping occurred after bootstrapping the data.

The RNA3 sequence for the UK P type is the same for years 2001 and 2002. The branches from which the UK P type arises is not significant (at 75%) and the bootstrap analysis would suggest that the RNA3 from the UK P types is more closely related to the B type than the A type. As the UK P type isolates cluster together and do not cluster significantly with either A or B

types, this would suggest that the UK P type is more distantly related to the A and B types compared with P types from France and Kazakhstan.

RNA 4

Analysis of the cluster tree for BNYVV RNA4 shows 2 main groupings of A, with French and Kazakhstan P types and B with UK and Japanese P types. The branches supporting these groupings are well supported with bootstrap values of 100 for both. Within the P/B group, there are sub-clusters for B and P types. There is strong support for the sub-cluster of UK and Japanese P types, and bootstrap analysis also shows that the UK P type is significantly different (bootstrap value = 93) from the Japanese P type. In addition, the sequence for the UK P type was the same for years 2001, 2002 and 2003. With the P/A group, there are sub-clusters of A and P types. The sub-cluster of A types is significantly different (bootstrap value = 99) from the P type cluster. The results suggest that the RNA4 from the UK and Japanese P types are more closely related to B than A types. Conversely, the French and Kazakhstan P types are more closely related to A types. However, as no P types cluster significantly with either A or B, the P RNA4 seems to be distinct from A and B types, but split into two sequence variants (Fig 3).

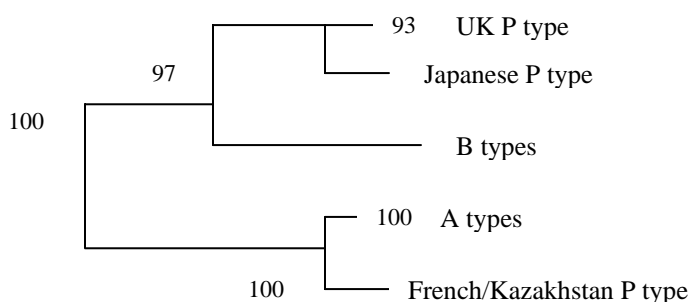

Fig. 3 A simplified cluster tree for RNA4 sequences showing groupings of P, A and B types of BNYVV. The tree was rooted with *Beet soil-borne virus* (not shown). The values indicate the number of times out of 1000 that this grouping occurred after bootstrapping the data.

RNA5

Analysis of the cluster tree for BNYVV RNA5 shows 2 main groupings, one of mainly Chinese and Japanese P types and the other group of 2 Japanese isolates with French and UK P types. Bootstrap analysis shows that the branches from which these groupings arise has a bootstrap value of 100% indicating that these two groups are significantly different from each other. There are sub-clusters within the Chinese Japanese group indicating differences in sequence, however, these clusters are not significantly different from each other. Within the other main group there is strong support for sub-cluster of UK and French P types with a bootstrap value of 99% showing that these P types are significantly different from the two Japanese P types within this main group. While the results suggest that the RNA5 from the UK is most closely related to the French P types, these two groups also sub-cluster with bootstrap values of 94% for UK P types and 95% for the French P types showing that these P types are significantly different from each other (Fig 4).

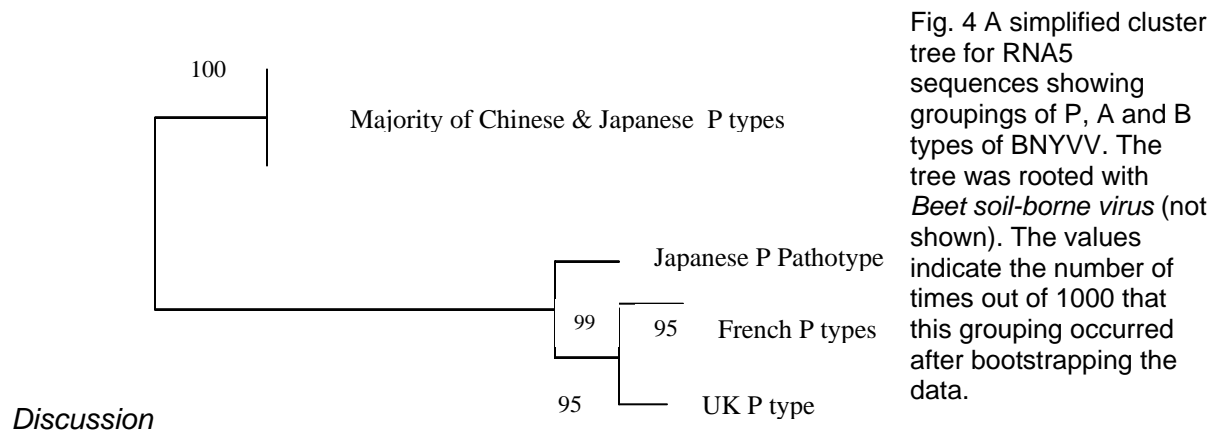

Fig. 4 A simplified cluster tree for RNA5 sequences showing groupings of P, A and B types of BNYVV. The tree was rooted with *Beet soil-borne virus* (not shown). The values indicate the number of times out of 1000 that this grouping occurred after bootstrapping the data.

Discussion

Analysis of BNYVV RNA sequence data for all RNA species showed that BNYVV isolates containing the RNA5 collected from the Norwich site formed a distinct group that was separate from A and B pathotypes. In addition, when the UK BNYVV P type sequence data was aligned from isolates collected in 2001, 2002 and 2003, all sequences were identical for each of the respective RNA species. From these results, we can conclude that only the UK P type was present in the infected field sampled. These results correspond to the finding of Koenig *et al.*, (1997), who state they have only found RNA 5 consistently in sugar beet infected with the P-type of BNYVV, and not in beets infected with other BNYVV types. Analysis of RNA2 data shows that the UK P pathotype clusters more closely with A types than B types, suggesting that A and P types are more closely related. Miyanishi *et al.* (1999) and Koenig & Lennefors (2000) have also reported that the majority of P pathotypes from Europe, Kazakhstan and East Asia are more closely related to A than B types.

Two of the Norwich isolates were found to be negative for RNA5 by TaqMan PCR. Sequence data for these two isolates showed that RNA 2, 3 and 4 were identical to the RNA5-containing isolates. The results suggest that it may be possible for a P pathotype to exist in field soil and infect sugar beet plants without an RNA5 being packaged within the virus particle. Tamada *et al.* (1989) showed that RNA5 was a distinct RNA species and is not a deleted form of RNA 3 or 4. These workers, however, also detected a smaller RNA, which they named RNA6. They suggested that RNA6 may be a deleted form of RNA5 and may be present in undetectable levels in fields (Tamada *et al.*, 1989). Tamada *et al.* (1989,1999) have also shown that it is possible to infect plants with different combinations of RNA species. The presence of RNA3 appears to be important for development of symptom expression and the presence of RNA1, 2, 3 and 4 are essential for survival of BNYVV in nature. Although RNA5 is not essential for survival, their studies have shown that it may be associated with symptom development and may produce a synergistic effect with RNA3 in some cultivars (Kiguchi *et al.*, 1996). In this study, we did not investigate how P types without RNA5 affected rhizomania symptom development; however, this may be worth examining in a future project.

Analysis of sequence data for RNAs 2, and 4 shows the UK P pathotype clustering with Japanese P type isolates. In contrast, the French and Kazakhstan P types clustered in separate group for RNAs 2, 3, 4, 5. RNA5 analysis showed that the UK P type clustered more closely with the French P pathotype whilst the Japanese and Chinese P pathotypes clustered together in a separate group. The results for RNA5 agree with previous molecular analyses of European (French) and Kazakhstan BNYVV P pathotypes, which showed that RNA5 from France and Kazakhstan were almost identical, and that RNA5 from various East Asian BNYVV sources were very different (Koenig & Lennefors, 2000). Our results for RNA 2 and 4 also agree with the

Koenig and Lennefors (2000) analyses where they again found close similarities with BNYVV P type from France and Kazakhstan. A study by Miyanishi *et al.* (1999) showed that it was possible to have sequence variants of BNYVV RNA5. In their study, Miyanishi *et al.* (1999), found that RNA5 fell into 3 groups and in one of the 3 groups, RNA5 isolates fell into a further 3 clusters. In their study, geographical distribution was unrelated to group variant. The Miyanishi *et al.*, (1999) study used the complete sequence of the RNA5 p26 gene to do comparisons. At present only part of the UK P pathotype RNA5 p26 gene has been sequenced. In order to get a better understanding of the relationship of the UK RNA5 with other RNA5 sources, we aim to sequence the whole of the gene in the future. In addition, it would be interesting to sequence P type isolates from the second infected site at Norwich, so see if this clusters with the P type analysed in this study.

The results presented here confirm that three distinct pathotypes occur in the UK, A, B and P, and that it would be unlikely for molecular interaction to take place between the pathotypes. In other words it is unlikely that an A or B pathotype would randomly acquire a RNA5 by chance packaging during transmission. Koenig & Lennefors (2000) sequenced BNYVV from parts of Europe (excluding the UK) and Central and East Asia and found that A, B and P types are strongly conserved.

References

- Harju VA, Mumford RA, Blockley A, Boonham N, Clover GRG, Weekes R, Henry CM. (2002). Occurrence in the United Kingdom of beet necrotic yellow vein virus which contain RNA5. *Plant Pathology* **51**, 811.
- Kiguchi T, Saito M, Tamada T. (1996). Nucleotide sequence analysis of RNA5 of five isolates of *Beet Necrotic Yellow Vein Virus* and the identity of a deletion mutant. *Journal of General Virology* **77**, 575-580.
- Koenig R, Haeberle AM, Commandeur U. (1997). Detection and characterization of a distinct type of *Beet Necrotic Yellow Vein Virus* RNA5 in a sugarbeet growing area in Europe. *Archives of Virology* **142**, 1499-1504.
- Koenig R, Lennefors BL. (2000). Molecular analyses of European A, B and P type sources of *Beet Necrotic Yellow Vein Virus* and detection of the rare P type in Kazakhstan. *Archives of General virology* **145**, 1561-1570.
- Miyanishi M, Kusume T, Saito M, Tamada T. (1999). Evidence for three groups of sequence variants of *Beet Necrotic Yellow Vein Virus* RNA5. *Archives of Virology* **144**, 879-892.
- Tamada T, Shirako Y, Abe H, Saito M, Kiguchi T, Harada T. (1989). Production and pathogenicity of isolates of *Beet Necrotic Yellow Vein Virus* with different numbers of RNA components. *Journal of General Virology* **70**, 3399-3409.
- Tamada T, Uchino H, Kusume T, Saito M. (1999). RNA3 deletion mutants of *Beet Necrotic Yellow Vein Virus* do not cause Rhizomania disease in sugar beets. *Phytopathology* **89**, 1000-1006.

ANALYSIS OF THE SUBGENOMIC RNAS AND THE SMALL ORFS OF BEET BLACK SCORCH VIRUS

Xuefeng Yuan, Yunhe Cao, Dehui Xi, Lihua Guo, Chenggui Han, Dawei Li, Jialin Yu

State Key Laboratory of Agro-biotechnology, College of Biological Sciences, China Agricultural University, Beijing 100094, China

Summary

A full-length cDNA of *Beet black scorch virus* isolate Ningxia (BBSV-N) was modified by site-directed mutagenesis to permit *in vitro* transcription of mutant viral RNAs. Mutagenesis reveals that sgRNA1 transcription is initiated at G²²⁰⁹ within the P82 polymerase subunit open reading frame (ORF) and that transcription of sgRNA2 begins at G²⁵²⁶ within the nested p7b/p5' ORF. Initiation codon shifting or premature termination of translation of three ORFs (P7a, P7b and P5') encoded by sgRNA1 revealed that each of the genes are required for localized movement, accumulation of viral RNAs and formation of local lesions on the leaves of *Chenopodium amaranticolor*. Microscopic observations of the distribution of a green fluorescent protein (GFP) fusion to an N-terminal portion of the capsid protein also confirmed the results. In contrast, elimination of sgRNA2 showed that the BBSV coat protein is dispensable for viral RNA accumulation and the appearance of local lesions. However, disruption of the small P5 ORF previously predicted by computer analyses to originate near the C-terminus of the P82 ORF had no effect on the disease phenotype, suggesting that this ORF may represent a cryptic nonessential ORF.

Introduction

Beet black scorch virus (BBSV), a new species of the *Necrovirus* genus, causes necrotic local lesions on the leaves of *Chenopodium* spp. after mechanical inoculation in the greenhouse. In a previous report, seven open reading frames (ORFs) were predicted in the BBSV genome by computer analysis. The P22 and P82 ORFs are thought to encode the viral RNA polymerase subunits. The functions of the small ORFs of P5, P7a, P7b and P5' located in the central region of the BBSV RNA genome have not been identified, but similar proteins encoded by a sgRNA in TNV-D and TNV-D^H are required for cell-to-cell movement. This study reports mutagenesis experiments to investigate the mechanisms whereby the downstream ORFs of BBSV are translated from two sgRNAs, and the requirements of the encoded proteins for cell-to-cell movement and local lesion formation in *C. amaranticolor*.

Materials and Methods

BBSV isolate N (BBSV-N) was collected from Ningxia Province and propagated in *C. amaranticolor* by mechanical inoculation. The BBSV-N sequence reported previously was used to design mutagenesis strategies throughout this study. When the local lesions first appeared at 3 to 4 days post inoculation (dpi), virus particles were purified from infected leaves by sucrose density gradient centrifugation and used for viral RNA extraction. One g of the purified virus was used directly to determine the amino acid sequence of the coat protein.

In order to confirm the 5' sequences of BBSV sgRNAs, dsRNA templates corresponding to BBSV sgRNA1 or sgRNA2 were extracted from infected *C. amaranticolor* leaves on CF-11 cellulose columns. Primers were designated for initiation of the RACE RT-PCR to obtain full-length BBSV cDNA, starting with one G residue after a T7 promoter. The cDNA clone of wild type BBSV-N was confirmed by nucleotide sequencing of the both strands and named pUBF52 (See Fig. 1). BBSV mutants containing substituted nucleotide(s) were derived from pUBF52 by site-directed mutagenesis of PCR amplifications using appropriate primer pairs corresponding to specific regions of the BBSV genome. To facilitate analyses of BBSV

cell-to-cell movement, a green fluorescent protein (GFP) gene of GFPmut2 was fused to the *Eco*NI site (position 2715 nt) at 5' proximal region of the BBSV P24 gene to create the plasmid pBGFP. In addition, three other mutants (p7a-Mut-GFP, p7b-Mut-GFP and p5'-Mut-GFP) were derived by recombination of the plasmid pBGFP with p7a-Mut-G²²²⁹, p7b-Mut-G²⁴²² or p5'-Mut-C²⁴³⁵ (See Fig. 1).

The synthesized RNAs were mixed with an equal volume of inoculation buffer and rubbed on *C. amaranticolor* leaves. At 3 to 4 dpi, total RNA was extracted from the inoculated leaves and precipitated with 2 M LiCl. By Northern-blot analysis, replication of BBSV RNAs was assessed with a cDNA probe complementary to 300 nts at the 3' proximal end of the BBSV genome. *C. amaranticolor* leaves were inoculated with pBGFP or the mutant derivatives by bombardment and GFP fluorescence was visualized under a laser scanning microscope.

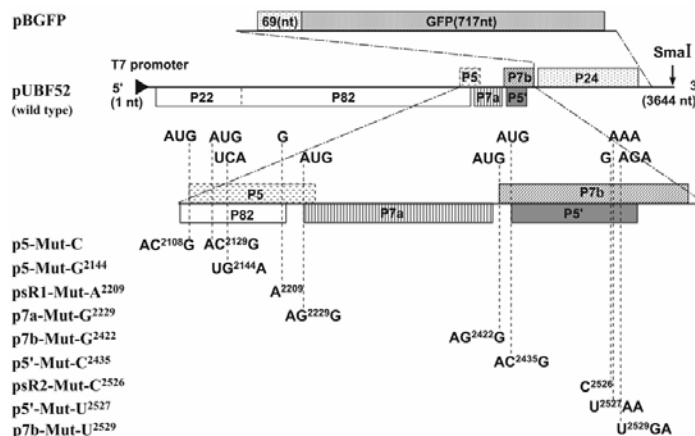

Fig. 1 BBSV cDNAs used for in vitro transcription.

Results and Discussion

To determine the authentic initiation codon of the BBSV capsid P24 protein, five amino acids at the N' terminus of purified viral protein were sequenced and determined to be Ala-Pro-Lys-Arg-Asn, consistent with initiation of translation at the first AUG of positions 2647 to 2649 predicted earlier by computer analysis.

dsRNAs corresponding to the sgRNAs were used to amplify the 5' regions of the sgRNAs by RACE RT-PCR to define the two sgRNAs (data not shown). Sequencing from both strands of the cDNAs indicated that the 5' proximal nucleotide are guanines corresponding to position 2209 nt (G²²⁰⁹) or 2526 nt (G²⁵²⁶) of the BBSV genome that possibly represents the transcription start site of the sgRNA1 and sgRNA2, respectively. To verify this, BBSV cDNA mutant psR1-Mut-A²²⁰⁹ and psR2-Mut-C²⁵²⁶ were constructed for *in vitro* transcription. These mutants contain an adenine (A) or a cytosine (C) substitution for the residues in pUBF52 (Fig. 1). After mechanical inoculation, local lesions failed to appear on the leaves of *C. amaranticolor* when transcripts from psR1-Mut-A²²⁰⁹ was used, while local lesions were produced within 3 to 4 dpi as wild type BBSV when in vitro transcripts of psR2-Mut-C²⁵²⁶ was used (data not shown). Northern blots of highly concentrated total RNA preparations from these leaves failed to visualize sgRNA1 and the coat protein was not evident in Western-blot (data not shown), but the presence of the gRNA and sgRNA2 could be detected in the heavily over loaded gels (Fig. 2). In contrast to the A²²⁰⁹, Northern-blot analyses of the viral

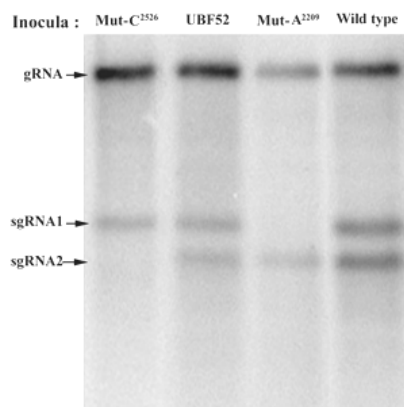

Fig. 2 Northern blot analysis of BBSV RNAs in *C. amaranticolor* leaves inoculated with in vitro transcripts. The total RNA sample loaded from leaves inoculated with the RNA transcripts of psR1-Mut-A²²⁰⁹ (Mut-A²²⁰⁹) was 50 times as concentrated as those from plants infected by wild type BBSV, pUBF52 (UBF52) or psR2-Mut-C²⁵²⁶ (Mut-C²⁵²⁶).

RNAs from inoculated leaves demonstrated that the C²⁵²⁶ mutation abolished sgRNA2 (Fig. 2) and eliminated the ability to detect the coat protein by Western blotting (data not shown). However, in contrast to the RNA reduction when leaves were inoculated with the psR1-Mut-A²²⁰⁹ transcripts, the gRNA and sgRNA1 of the mutated BBSV accumulated to similar levels as in plants infected by the pUBF52 transcripts or wild type BBSV (Fig. 2). These results and the nucleotide sequence from the RACE-PCR product amplified from the dsRNA template, provide persuasive evidence that the residues of G²²⁰⁹ and C²⁵²⁶ represent the transcriptional start site of sgRNA1 or sgRNA2, respectively. Moreover, since local lesion failed to develop on leaves inoculated with *in vitro* transcripts of psR1-Mut-A²²⁰⁹, one or more of the proteins potentially encoded by sgRNA1 (P7a, P7b or P5) are presumed to be required for cell-to-cell movement.

In order to clarify these functions, seven site-directed modifications of the translation initiation codons in each of the small ORFs were constructed (Fig. 1). After inoculation with transcripts from p5-Mut-C or p5-Mut-G²¹⁴⁴, local lesions indistinguishable from those induced by the wild type virus appeared on *C. amaranticolor* within 3 to 4 (data not shown). Northern blots also revealed the viral RNA components from infected leaves accumulated to levels similar to those produced by wild type RNA (pUBF52 transcripts) (Fig. 3). For the functions of the sgRNA1 encoded P7a, P7b and P5' proteins, *in vitro* transcripts from each of the five mutants (p7b-Mut-G²⁴²², p7a-Mut-G²²²⁹, p5'-Mut-C²⁴³⁵, p5'-Mut-T²⁵²⁷, and p7b-Mut-T²⁵²⁹) was used for mechanical inoculation of *C. amaranticolor* and all the inoculated leaves remained symptomless for several weeks. Furthermore, leaves inoculated with the mutants contained very low levels of viral RNA compared to those inoculated with wild type BBSV (Fig. 4), although the mutants and the wild type virus had similar ratios of gRNA and sgRNAs. In conclusion, the results from site-directed mutagenesis of the translational codons of ORF P7a, P7b and P5' provide evidence that proteins encoded by all three small ORFs are individually required for production of visible local lesions and suggest that the low levels of viral RNAs result from replication in primarily infected cells from which the virus is unable to move. This hypothesis was confirmed by expression of GFP:CP fusion mutants visualized in leaves tissues after virus infection with the pBFP construct the derivative mutants (p7a-Mut-GFP, p7b-Mut-GFP and p5'-Mut-GFP) (data not shown).

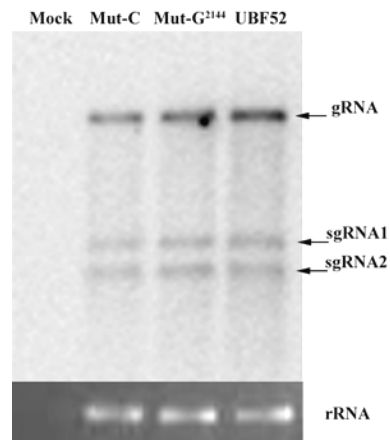
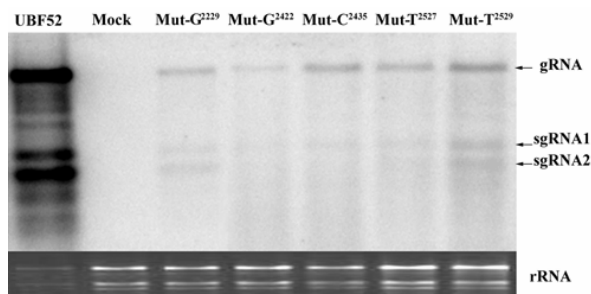

Fig. 3 Northern blot of BBSV RNAs in *C. amaranticolor* inoculated with the translational mutants of the predicted ORF P5.

Fig. 4 Northern blot of BBSV RNAs in *C. amaranticolor* inoculated with the P7a, P7b and P5' initiation codon mutants. Note that the RNA concentration from leaves infected with wild type BBSV transcripts was diluted 5-fold less than other samples before loading on the gel.



The results presented in this paper show that the genes positioned downstream of the viral RNA polymerase are expressed via translation of sgRNAs, as is the case for a large number of positive-strand RNA viruses. In the case of BBSV, our site-directed mutagenesis of the transcriptional start sites demonstrates that two sgRNAs are involved in expression of the 3'

terminal ORFs. The mutation at G²²⁰⁹ eliminates sgRNA1 expression and translation of the three small proteins of P7a, P7b and P5', whereas the G²⁵²⁶ mutation abrogates expression of sgRNA2 and expression of the coat protein. All these properties of BBSV are highly similar to those of TNV-D. Based on these results, a model for the genomic organization and expression strategy of BBSV is proposed in Fig 5.

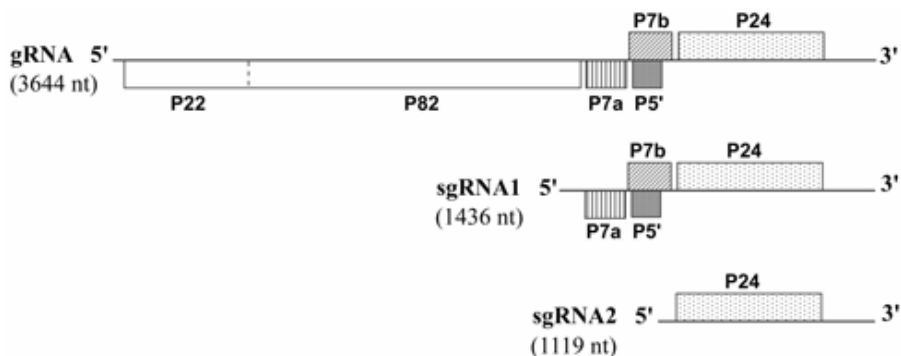

Fig. 5 Proposed BBSV genomic organization and subgenomic expression.

This work was supported by grants 30270063 and 30325001 from the National Natural Science Foundation of China (NSFC) and grant 2002AA206641 from National High Technology R&D Program of China.

References

- Cao, Y. H., Z. N. Cai, Q. Ding, D. W. Li, C. G. Han, J. L. Yu, and Y. Liu. (2002). The complete nucleotide sequence of Beet black scorch virus (BBSV), a new member of the genus *Necrovirus*. *Arch. Virol.* 147:2431-2435.
- Coutts, R. H., J. E. Rigden, A. R. Slabas, G. P. Lomonosoff, and P. J. Wise. (1991). The complete nucleotide sequence of tobacco necrosis virus strain D. *J. Gen. Virol.* 72:1521- 1529.
- Drouzas, A. D., S. K. Offei, and R.H. Coutts. (1996). Subcellular location and expression of tobacco necrosis *Necrovirus p7a* protein. *J. Phytopathol.* 144:297-299.
- Guo, L. H., Y. H. Cao, D. W. Li, S. N. Niu, Z. N. Cai, C. G. Han, Y. F. Zhai, and J. L. Yu. (2005). Analysis of nucleotide sequences and multimeric forms of a novel satellite RNA associated with beet black scorch virus. *J. Virol.* 79:3664-3674.
- Meulewaeter, F., M. Cornelissen, and J. van Emmelo. (1992). Subgenomic RNAs mediate expression of cistrons located internally on the genomic RNA of tobacco necrosis virus strain A. *J. Virol.* 66:6419-6428.
- Miller, W. A. and G. Koev. (2000). Synthesis of subgenomic RNAs by positive-strand RNA viruses. *Virology* 273:1-8.
- Molnár, A., Z. Havelda, T. Dalmay, H. Szutorisz, and J. Burgyan. (1997). Complete nucleotide sequence of tobacco necrosis virus strain D^H and genes required for RNA replication and virus movement. *J. Gen. Virol.* 78:1235-1239.
- Offei, S. K., and R. H. Coutts. (1996). Location of the 5' termini of tobacco necrosis virus strain D subgenomic mRNAs. *J. Phytopathol.* 144:13-17.

Role of potato mop-top virus triple gene block proteins in intracellular movement and replication

Lesley Torrance, Graham Cowan, Sophie Haupt*, Trudi Gillespie, Angelika Ziegler

Scottish Crop Research Institute and University of Dundee*, Invergowrie, Dundee DD2 5DA
Scotland, UK
L.Torrance@scri.ac.uk

Abstract

The intracellular localisation of fluorescent protein-tagged triple gene block movement protein TGB 2 of *Potato mop-top virus* (PMTV) was investigated. The fusion protein was transiently expressed in *Nicotiana benthamiana* epidermal cells under the control of the 35S promoter and the cells were examined by confocal laser-scanning microscopy (CLSM). In addition, thin sections of virus-infected potato leaves were examined by electron microscopy. The CLSM results show that fluorescent tagged PMTV TGB2 associates with the outer membranes of modified chloroplasts and EM studies show that chloroplasts in infected leaves are distorted with cytoplasmic invaginations and protrusions. The results suggest that the TGB2 movement protein may play an additional role in establishing virus replication complexes in chloroplasts.

Introduction

Plant viruses have evolved different strategies for cell-to-cell movement that require one or more virus-encoded movement proteins. Viruses in eight different genera utilise a conserved module of three proteins known as the triple gene block of movement proteins (TGB). There are two groups of TGB-containing viruses, the Hordei-like group including *Barley stripe mosaic virus* (BSMV) and *Potato mop-top virus* (PMTV) and the Potex-like group including *Potato virus X* (PVX) (reviewed by Morozov and Solovyev, 2003). Each of the TGB is essential for movement. Hordei-like viruses do not require coat protein for cell-cell movement whereas coat protein is essential for Potex-like TGB viruses.

In this paper we focus on the Hordei-like TGB virus PMTV. It is thought that TGB1 interacts with RNA and forms part of the ribonucleoprotein (RNP) complex. It has been shown that green fluorescent protein (GFP) tagged TGB1 requires the presence of TGB2 & 3 for localisation to the plasma membrane and plasmodesmata (PD) (Zamyatnin et al., 2004). TGB 2 & 3 are integral membrane proteins, they act together to deliver the TGB1RNP complex from the site of virus replication to the PD by a vesicle mediated transport process. Our results using fluorescent protein-tagged PMTV-TGB 2 & 3 have revealed that TGB2 & TGB3 co-localise in cellular membranes and mobile granules, utilise the actin-ER network to facilitate movement to the cell periphery and PD and associate with components of the endocytic pathway. There was no evidence of association with microtubules and the results suggest that TGB2 & TGB3 do not move cell-to-cell (Haupt et al., 2005). This paper presents results of further studies that reveal a putative additional functional role for PMTV TGB2 in virus replication.

Materials and Methods

The gene encoding PMTV TGB2 was fused to the 3'(C-) terminus of the monomeric RFP sequence and then cloned into the plasmid vector pRTL2. Plasmid DNA was introduced into epidermal cells by biolistic bombardment for transient expression of the fusion protein under the control of the 35S promoter. The cells were examined by confocal microscopy after 1-2 days. The plasmids were bombarded to epidermal cells of *Nicotiana benthamiana*. Confocal laser-

scanning microscopy (CLSM) was done as described by Haupt et al. (2005). PMTV-infected leaves were fixed and dehydrated as described in Oparka et al. (1999) before embedding in LR White resin. Ultrathin sections were mounted on pyroxylin-coated nickel grids, post-stained with uranyl acetate and lead citrate, and examined using a Phillips CM10 electron microscope.

Results and Discussion

Transient expression of PMTV mRFP-TGB2 in *N. benthamiana* epidermal cells showed association of mRFP with ER membranes and small punctate spots (granules) of red fluorescence moving on the ER. It also localised to the membranes of larger vesicles (approx. 4µm diameter; Fig. 1). These vesicles were often seen clustered around the nucleus. The cells were scanned using excitation and emission wavelengths of 488 nm and 680 – 700 nm, respectively, these settings detect chlorophyll but do not detect mRFP. CLSM with these settings revealed the presence of chlorophyll fluorescence inside some of the vesicles (Fig. 2). The cells were also scanned over a wavelength range (495-755nm) which revealed that the vesicles contained material which gave the expected spectrum for chlorophyll A (maximum at 680nm; Fig3). The chlorophyll fluorescence did not completely fill the vesicle. Electron microscopy of thin sections of PMTV infected potato epidermal cells showed that chloroplasts were abnormally rounded or distorted and contained cytoplasmic inclusions (Fig. 4). Further experiments are in progress to provide evidence that PMTV replicates in the modified chloroplasts.

Fig. 1

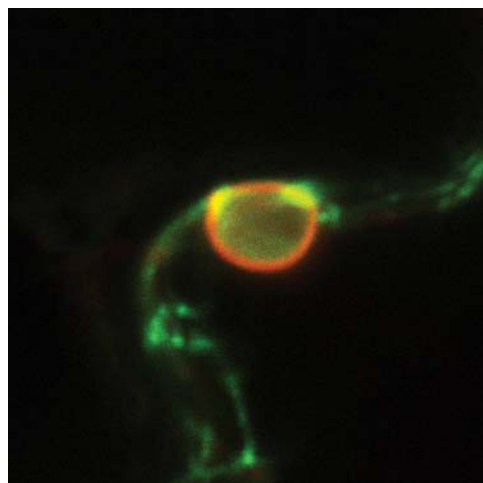

Fig. 1. Transient expression of 35S PMTV mRFP-TGB2 in *N. benthamiana* epidermal cells: Red fluorescence is observed in the membranes of vesicles (approx. 4 µm diameter).

Fig. 2

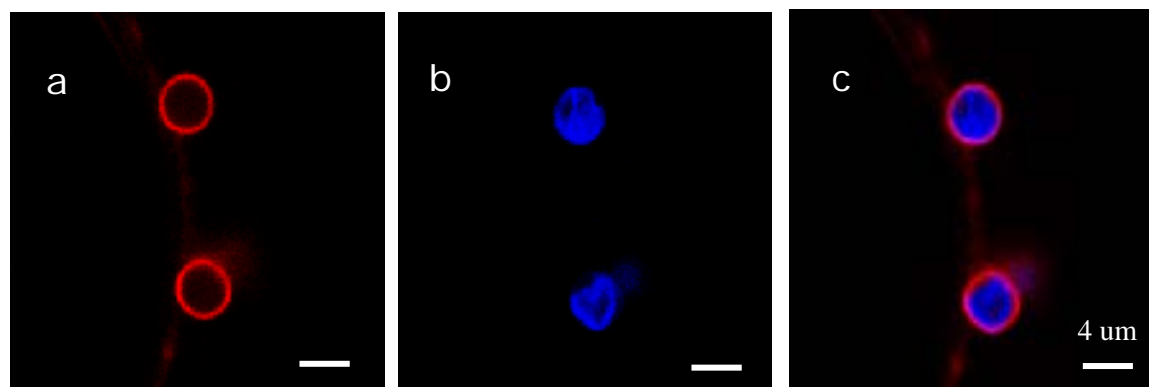

Fig. 2. Cells scanned separately for mRFP (a) or chlorophyll (b) reveal presence of chlorophyll in vesicles (artificially coloured blue) (c) overlay.

Fig. 3

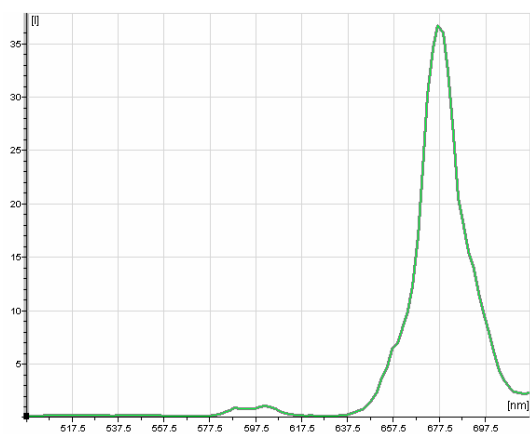

Fig. 3 Wavelength scan (495-755nm) of vesicles in Fig 2 reveals presence of chlorophyll inside the vesicles (peak 680nm)

Fig. 4

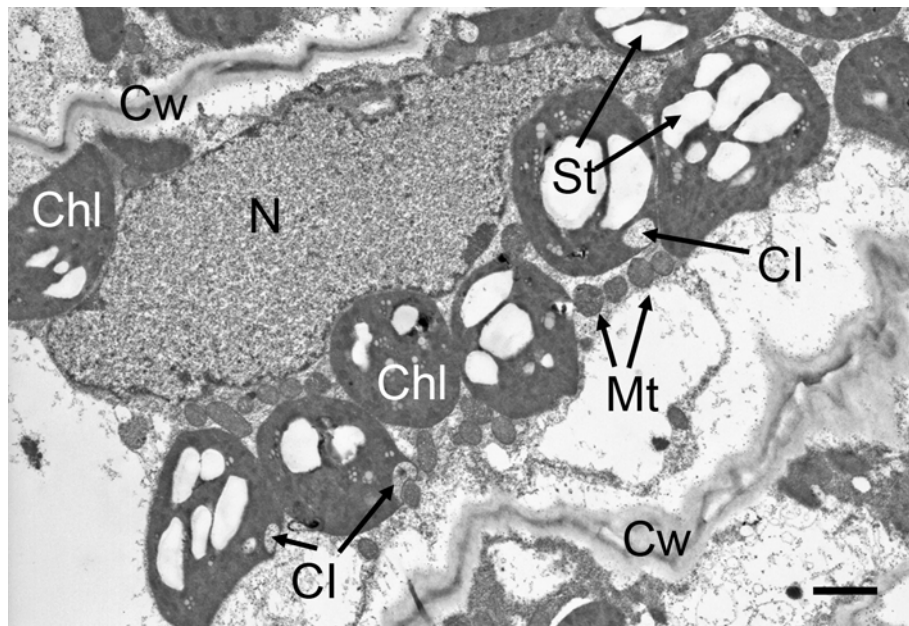

Fig. 4. Electron micrograph of thin section of PMTV-infected potato: Membrane bound cytoplasmic inclusions (CI) seen inside a distorted chloroplast; St = starch granule; Mt = mitochondria; Cw = cell wall; N = nucleus, bar = 1 μ m.

Acknowledgements

SCRI is grant-aided by the Scottish Executive Environment and Rural Affairs Department

References

- Morozov, S.Yu., and Solovyev, A.G. (2003). Triple gene block: modular design of a multifunctional machine for plant virus movement. *J. gen. Virol.* **84**, 1351-1366.
- Haupt, S., Cowan, G.H, Ziegler, A., Roberts, A.G., Oparka, KJ and Torrance, L. (2005) Two plant-viral movement proteins traffic in the endocytic recycling pathway. *Plant Cell* **17**: 164-181.
- Oparka, K.J., Roberts, A.R., Boevink, P., Santa Cruz, S., Roberts, I., Pradel, K.S., Imlau, A., Kotilzky, G., Sauer, N. and Epel, B. (1999). Simple, but not branched, plasmodesmata allow the nonspecific trafficking of proteins in developing tobacco leaves. *Cell* **97**: 743-754.
- Zamyatnin, A.A. Jr., Solovyev, A.G., Savenkov, E.I., Germundsson, A., Sandgren, M., Valkonen, J.P.T., and Morozov, S.Y. (2004). Transient Coexpression of Individual Genes Encoded by the Triple Gene Block of *Potato mop-top virus* Reveals Requirements for TGBp1 Trafficking. *MPMI* **17**, 921-930.

FORMATION OF VIRUS-LIKE PARTICLES FROM BEET NECROTIC YELLOW VEIN VIRUS COAT PROTEIN EXPRESSED BY A CACTUS POTEXVIRUS-BASED VECTOR CONSTRUCT

R. Koenig, D.-E. Lesemann, J. Engelmann, S. Loss, J. Schiemann and W. Burgermeister

Biologische Bundesanstalt für Land- und Forstwirtschaft, Institut für Pflanzenvirologie, Mikrobiologie und biologische Sicherheit, Messeweg 11, D-38104 Braunschweig, Germany

Summary

A plant viral expression vector was developed on the basis of biologically active, full-length cDNA clones of *Zygocactus virus X* (ZVX). The expression of foreign genes, inserted via newly created *Ascl* and *SpeI* sites, is driven by the ZVX coat protein (cp) subgenomic promoter. The vector initiates local symptomless infections in *Chenopodium quinoa*, *Tetragonia expansa*, and sugarbeet. The cp genes of Beet necrotic yellow vein virus and Soil-borne cereal mosaic virus were readily expressed, provided that the newly created *Ascl* and *SpeI* sites did not replace the variable region downstream of the putative ZVX cp subgenomic promoter. Immunoelectron microscopy revealed that the expressed cps assembled into virus-like particles.

Introduction, Methods, Results and Discussion

Full length cDNA clones of plant viruses can be modified in such a way that inserted foreign genes or genome portions are amplified and - under the control of a suitable promoter - also expressed in plants. Such vector systems are valuable tools for many applications (Fig. 1)

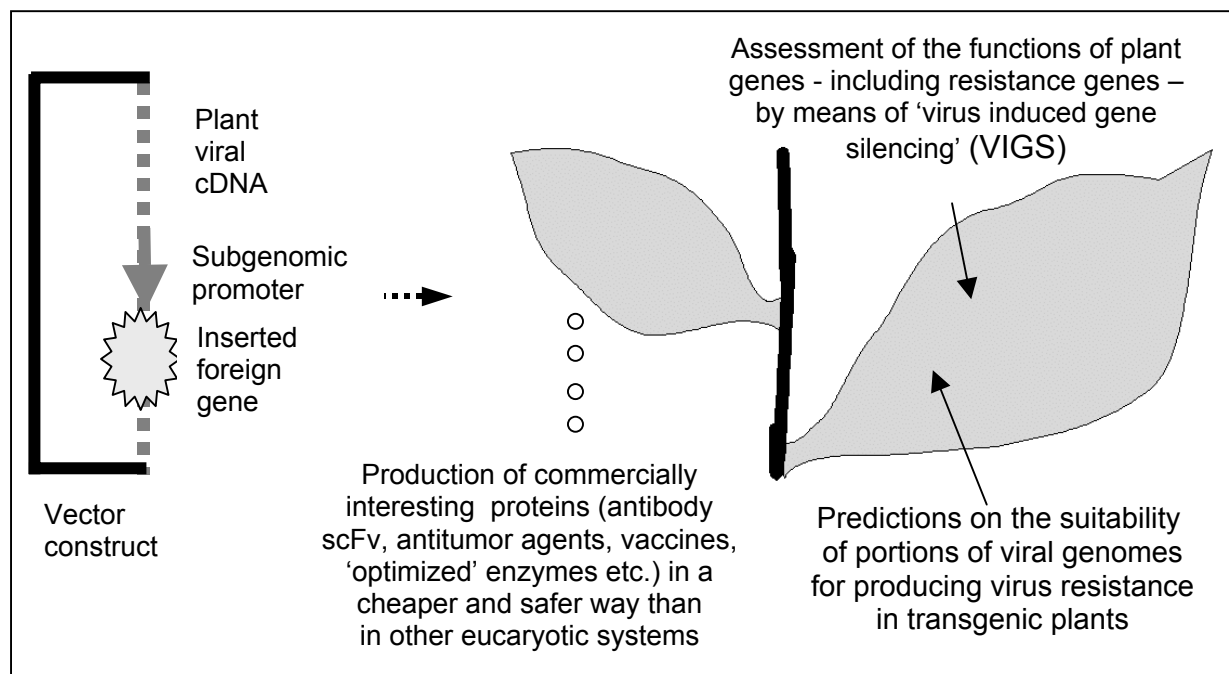

Fig. 1. Various applications of plant viral vector constructs

(reviewed e.g. by Pogue *et al.*, 2002). Most of the plant viral vector systems described so far are suitable mainly for solanaceous plants. To be able to study various aspects of the zizania disease we have developed a vector based on Zygoxactus virus X (ZVX - Koenig *et al.*, 2004) cDNA which is able to initiate local symptomless infections in the major experimental and natural hosts of Beet necrotic yellow vein virus (BNYVV), i.e. *Chenopodium quinoa*, *Tetragonia expansa* and sugarbeet. The design of the vector (Fig. 2B) resembles that of certain tobamovirus-based vectors (Shivprasad *et al.*, 1999). The ZVX cp subgenomic promoter is used to drive the expression of foreign genes inserted via newly created *Ascl* and *SpeI* sites. Since the ZVX cp subgenomic promoter is thus no longer available for the expression of the ZVX cp gene, most of this gene was replaced by the corresponding sequence of the related Schlumbergera virus X (SVX) and its cp subgenomic promoter. This enables the formation of potexvirus particles encapsidated by a SVX/ZVX hybrid cp (Figs. 2 and 3).

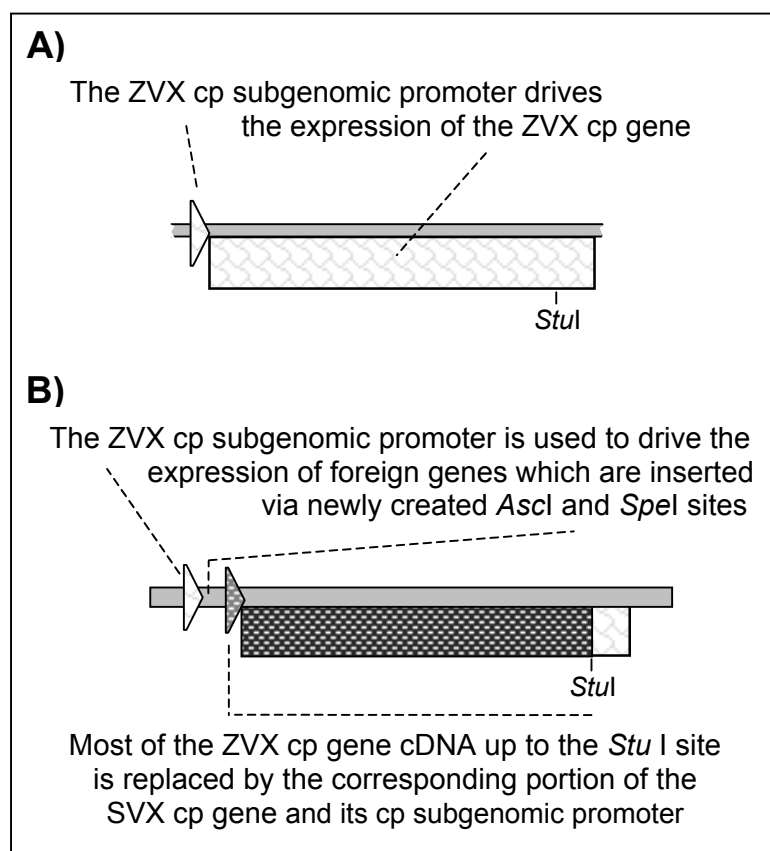
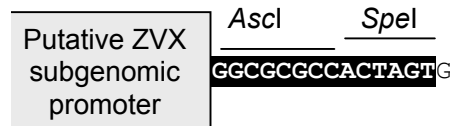
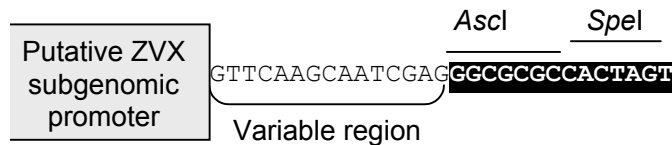
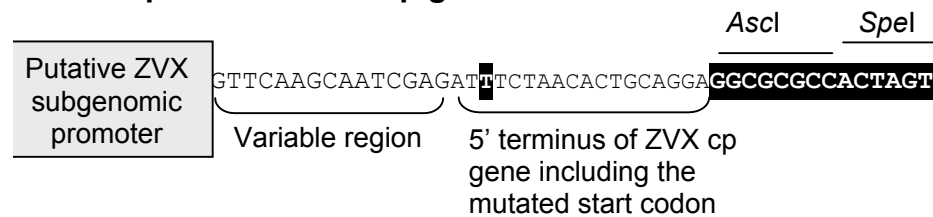

Fig. 2. Genome organization of wild-type ZVX (A) and modifications introduced into the sequence to allow the expression of foreign genes (B)

The exact size and base composition of potexviral cp subgenomic promoters is not known. It is assumed that a highly conserved sequence GSTTAAGTT(X₁₂₋₁₃)GAA (written as DNA) upstream of potexviral cp genes represents this promoter (Chen *et al.*, 2004). Between this putative subgenomic promoter region and the cp genes there is a stretch of nucleotides in potexviral genomes that is highly variable in size and composition. In the ZVX genome it consists of 15 nucleotides. For introducing into our constructs the *Ascl* and *SpeI* sites, needed for the insertion of foreign genes, three alternatives were chosen (Fig. 3). In pA these two restriction sites have replaced most of the variable region, in pB the variable region was retained and the two sites were inserted immediately downstream of it and in pC the two sites

pA: Replacement of most of the variable region**pB: Insertion directly downstream of the variable region****pC: Insertion downstream of the 5' part of the ZVX cp gene**

Formation of BNYVV cp was neither detected by ELISA nor by immunoelectron microscopy

Formation of BNYVV cp was readily detected by ELISA and BNYVV-like particles showing the typical axial canal were readily detected by means of immunoelectron microscopy



With all three constructs potexvirus particles were readily detected in the infected plants by means of immunoelectron microscopy suggesting that the inserted SVX cp subgenomic promoter (downstream of the Spel site) is functional and drives the expression of a SVX/ZVX hybrid cp able to encapsidate the transcribed RNA



Fig. 3. Various alternatives used to introduce the *Ascl* and *Spel* sites needed for the insertion of foreign genes into the ZVX-based vector sequence downstream of the putative ZVX coat protein (cp) subgenomic promoter and ability of the resulting constructs pA, pB and pC to express inserted BNYVV cp gene in infected plants. The *Ascl* and *Spel* sites and the 'T' replacing the original 'G' in the ZVX cp start codon in pC are highlighted by white letters on a black background. Bar represents 100 nm. Magnification are the same in both electronmicrographs.

were inserted 18 nucleotides further downstream to include the 5' end of the ZVX cp gene with an inactivated ATG start codon. BNYVV cp gene was readily expressed from constructs pB and pC, but not from construct pA in which the *Ascl* and *SpeI* sites have replaced most of the variable region downstream of the ZVX cp subgenomic promoter. This suggests that the variable region is either an essential part of the ZVX cp subgenomic promoter or that the palindromic *Ascl* site that is retained after the insertion of foreign genes interferes with the activity of the promoter when it is inserted directly downstream of it.

Immunoelectron microscopy revealed that in all three hosts BNYVV cp assembled into BNYVV-like particles showing the typical diameter of c. 20 nm and an axial canal (Fig. 3). The particles were decorated by BNYVV-specific antibodies, but showed no clear length maxima. Sedimentation analyses in isopycnic cesium chloride gradients suggested that these particles may contain nucleic acid. The particle formation by vector-expressed BNYVV cp was unexpected, because it occurred in the absence of the cp readthrough protein which has been found to be necessary for efficient particle formation in natural infections (Schmitt *et al.*, 1992). Particle formation was also observed with vector-expressed SBCMV cp.

The ability of our constructs to express the cp of BNYVV was retained when healthy leaves of *C. quinoa* were mechanically inoculated with sap from infected plants, it was lost, however, in the rarely occurring systemic infections. The localized and symptomless infections initiated by our constructs differ from those initiated by wild-type ZVX which almost always become systemic and are accompanied by the formation of a mild mosaic. For biosafety reasons this lowered aggressiveness of the virus derived from our constructs and the loss of its ability to express inserted genes in the rarely occurring systemic infections may be an advantage.

A detailed account of this work will be given by Koenig *et al.* (2006) *J. Gen. Virol.* (in press)

Acknowledgments

We are greatly indebted to the Deutsche Forschungsgemeinschaft (Grant Ko518/14-1), the Arbeitsgemeinschaft industrieller Forschungsvereinigungen (AiF Grant 14163 N72, GFP BR42/04) and the Niedersächsische Ministerium für Wissenschaft und Kultur (Grant ZN1401) for financially supporting different aspects of this work.

References

- Chen, J., Shi, Y. H., Adams, M. J. and Chen, J. P. (2005). The complete sequence of the genomic RNA of an isolate of Lily virus X (genus Potexvirus). *Arch Virol* **150**, 825-832.
- Koenig, R., Pleij, C. W. A., Loss, S., Burgermeister, W., Aust, H. and Schiemann, J. (2004). Molecular characterisation of potexviruses isolated from three different genera in the family *Cactaceae*. *Arch. Virol.* **149**, 903-907.
- Pogue, G. P., Lindbo, J. A., Garger, S. J. and Fitzmaurice, W. P. (2002). Making an ally from an enemy: Plant virology and the new agriculture. *Ann Rev Phytopathol* **40**, 45-74.
- Schmitt, C., Balmori, E., Jonard, G., Richards, K. E. and Guilley, H. (1992). In vitro mutagenesis of biologically active transcripts of beet necrotic yellow vein virus RNA 2: Evidence that a domain of the 75-kDa readthrough protein is important for efficient virus assembly. *Proc. Natl. Acad. Sci. USA* **89**, 5715-5719.
- Shivprasad, S., Pogue, G. P., Lewandowski, D. J., Hidalgo, J., Donson, J., Grill, L. K. and Dawson, W. O. (1999). Heterologous sequences greatly affect foreign gene expression in tobacco mosaic virus-based vectors. *Virology* **255**, 312-323.

RESISTANCE TO *MIRAFIORI LETTUCE BIG-VEIN VIRUS* IN TRANSGENIC LETTUCE CARRYING THE COAT PROTEIN GENE OF *LETTUCE BIG-VEIN ASSOCIATED VIRUS*

Y. Kawazu¹, R. Fujiyama¹, K. Sugiyama² and T. Sasaya³

¹ National Institute of Vegetable and Tea Science, Anō, Mie, 514-2392, Japan; ² National Agricultural Research Center for Hokkaido Region, Sapporo, Hokkaido, 062-8555, Japan; ³ The Ministry of Agriculture, Forestry and Fisheries of Japan, Kasumigaseki, Tokyo 100-8950, Japan

Summary

The coat protein (CP) gene of *Lettuce big-vein associated virus* (LBVaV) was transformed into lettuce to generate LBVaV-resistant lettuce. A construct of the LBVaV CP gene in antisense orientation in a binary vector pBI121 was transferred via *Agrobacterium tumefaciens*-mediated transformation into lettuce. T1 seedlings of 7 transgenic lines were inoculated with LBVaV using *Olipidium brassicae*. LBVaV was not detected in 5 plants derived from 3 lines, and the 5 plants were self-pollinated. T2 seedlings of selected plants were tested for LBVaV resistance, and one line (line A-2) was resistant to LBVaV while the other lines were susceptible. Transgenic line A-2 was also resistant to *Mirafiori lettuce big-vein virus* (MLBVV) and symptom expressions. Line A-2 was not immune to LBVaV or MLBVV, but more resistant to both viruses and symptom expressions than the resistant cultivar 'Pacific.'

Introduction

Lettuce big-vein is a soil-borne disease found in major lettuce production areas in the world. Infected lettuce plants develop vein-bandings in the leaves, and the leaves become ruffled and distorted.

Two viruses, *Lettuce big-vein associated virus* (LBVaV) and *Mirafiori lettuce big-vein virus* (MLBVV), have been found in lettuce with big-vein disease. Lot *et al.* reported that both viruses are transmitted by the obligately parasitic soil-inhabiting fungus *Olipidium brassicae*, and that MLBVV but not LBVaV causes big-vein disease (Lot *et al.*, 2002).

One of the most efficient methods to control big-vein disease is to use resistant cultivars. Big-vein resistant cultivars have been developed by conventional breeding method, but the resistance of cultivars released so far is insufficient for practical use because breeding sources with high resistance to the disease have not been found in lettuce (*Lactuca sativa* L.) (Bos & Huijberts, 1990; Ryder & Robinson, 1995).

Nucleotide sequences of *Lettuce big-vein associated virus* (LBVaV) and *Mirafiori lettuce big-vein virus* (MLBVV) were recently reported (Sasaya *et al.*, 2002; Sasaya *et al.*, 2004; van der Wilk *et al.*, 2002; Kawazu *et al.*, 2003), and it is now possible to transform lettuce with sequences of LBVaV or MLBVV in order to produce transgenic lettuce with resistance to LBVaV or MLBVV. LBVaV is not regarded as the causal agent of big-vein disease (Lot *et al.*, 2002), but it is possible that LBVaV is related to big-vein symptom expressions and MLBVV infections because LBVaV is frequently associated with big-vein disease.

In this report, we introduced the LBVaV CP gene into lettuce to make LBVaV-resistant lettuce, and examined big-vein symptom expressions and MLBVV infections in LBVaV-resistant transgenic lettuce. We report here that transgenic lettuce line was obtained

which was resistant not only to LBVaV but also to MLBVV and therefore repressed symptom expressions.

Materials and Methods

The full coding sequence for the LBVaV CP gene (1.2 kb) was inserted in antisense orientation into a binary vector pBI121. The resultant plasmid was referred to as pYK10.

Lactuca sativa L. cv 'Cisco' (Takii Seed Co., Ltd., Japan) was used for transformation. True leaves of 14-day-old seedlings were sectioned into small pieces (about 9 mm²), and were inoculated with *Agrobacterium tumefaciens* LBA4404 carrying pYK10. Regenerated shoots were selected on solid MS medium including 100 mg/l kanamycin sulfate. The presence of LBVaV CP gene in transgenic plants was confirmed by PCR of total genomic DNA using primers specific for CaMV 35S promoter and NOS terminator regions. Genomic DNA was extracted from lettuce leaves using a rapid method not requiring phenol or chloroform (Edwards *et al.*, 1991).

O. brassicae carrying both LBVaV and MLBVV was obtained from a lettuce field in Kagawa prefecture, Japan. Roots of 'Cisco' plants infected with both viruses were used for inoculation. Five g of roots were homogenized with 300 ml of de-ionized water using a juicer. They were then filtrated with one-layer gauze and poured onto the base of each seedling. Inoculated lettuce was kept in a plant growth chamber at 20°C during the daytime (14-hour photoperiod) and at 15°C at night.

Two discs were punched from randomly selected leaves of each lettuce plant using the lid of 2-ml microfuge tube, and disrupted with 0.4 ml of PBS-T. Protein extracts were used for LBVaV detection by Western blot analysis and for MLBVV detection by DAS-ELISA. Western blot analysis was conducted according to a standard procedure (Gallagher *et al.*, 1993). Mouse antiserum against LBVaV (diluted to 1/3000) was used for the primary antibody, and the alkaline phosphatase-conjugated goat antibody (Bio-Rad, USA) (diluted to 1/10000) was used for the secondary antibody. DAS-ELISA was performed essentially as described by Clark & Adams (1977). The antibody for coating and the antibody-alkaline phosphatase (AP) conjugate (Japan Plant Protection Association, Japan) were diluted to 1/500 and 1/1500, respectively.

Total RNA from lettuce leaves was extracted using ISOGEN (Nippon Gene Co., Ltd., Japan). Seventeen µg of purified RNA was used for Northern blot analysis. DNA fragment derived from the LBVaV CP gene or the MLBVV CP gene was DIG-labeled for hybridization.

Results and Discussion

In order to produce transgenic lettuce, 6200 leaf segments were inoculated with *A. tumefaciens* carrying the LBVaV CP gene in antisense orientation on the binary plasmid pYK10, and 30 independent plant lines (T0 generation) were regenerated. The presence of inserted CP gene was confirmed by PCR in 17 of 30 regenerated plants. Seeds were produced from 7 of 17 transgenic plants.

In order to screen resistant lines, T1 plants were inoculated with LBVaV using *O. brassicae*. Five to 10 plants of each T1 line were inoculated. Five plants derived from 3 lines were LBVaV-negative 56 days after inoculation, and they were self-pollinated for resistance test in T2 generation. Sixteen plants of each T2 line were inoculated with LBVaV using *O. brassicae*, and LBVaV infections were checked by Western blot analysis 31 days after inoculation. The percentages of LBVaV-positive plants were high

in all lines except line A-2; all line A-2 plants were LBVaV-negative. This result indicates that line A-2 is resistant to LBVaV.

Four plants of line A-2 or the parental non-transformed 'Cisco' cultivar were inoculated with LBVaV and MLBVV using *O. brassicae*. All 'Cisco' plants were LBVaV-positive, MLBVV-positive and symptomatic 31 days after inoculation. On the other hand, all line A-2 plants were LBVaV-negative. Moreover, all line A-2 plants were MLBVV-negative and without symptoms.

We attempted to detect RNA2 of LBVaV and RNA3 of MLBVV which encode coat proteins. Total RNAs were extracted from the leaves of line A-2 and 'Cisco' 31 days after inoculation. RNA2 of LBVaV was not detected in either of line A-2 plants while it was detected in all 'Cisco' plants (Figure 1A). RNA3 of MLBVV was detected in all 'Cisco' plants, but not detected in either line of A-2 plants (Figure 1B). Because line A-2 has the LBVaV CP gene in antisense orientation, the transgene is untranslatable. This suggests that the resistance to LBVaV in line A-2 is RNA-mediated. The resistance of line A-2 to MLBVV was unexpected because RNA-mediated resistance is only effective against viruses with a high degree of sequence homology to transgenes (van den Boogaart *et al.*, 1998). Further experiments are required to clarify the mechanism of the resistance to MLBVV in line A-2.

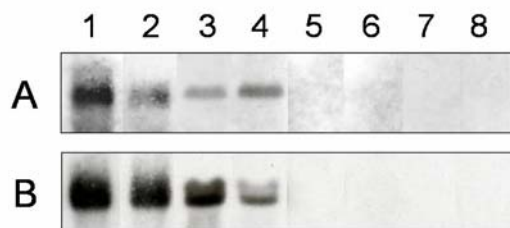

Fig. 1. Detection of RNAs of LBVaV and MLBVV by Northern blot analysis. Lanes 1-4: parental non-transformed cultivar 'Cisco'; Lanes 5-8: transgenic line A-2. (A) Detection of RNA2 of LBVaV. (B) Detection of RNA3 of MLBVV. Leaves were sampled 31 days after inoculation.

We examined the time-course of symptom expressions and virus infections in line A-2 and the resistant cultivar 'Pacific' (Figure 2). Six 'Cisco' plants, 6 'Pacific' plants and 8 line A-2 plants were inoculated. All 'Cisco' plants were LBVaV-positive, MLBVV-positive and symptomatic 40 days after inoculation. LBVaV and MLBVV infections and symptom expressions in 'Pacific' were delayed compared with those in 'Cisco.' Both LBVaV and MLBVV were detected, and big-vein symptoms were expressed in 15-40 % of transgenic plants 60-80 days after inoculation, which indicated that line A-2 was not immune to LBVaV or MLBVV. However, those percentages of line A-2 plants were lower than those of 'Pacific' plants indicating that line A-2 was more resistant to LBVaV, MLBVV and symptom expressions than the resistant cultivar 'Pacific.' 'Pacific' was released about 20 years ago, but no cultivar has been released that is more resistant to big-vein than 'Pacific' because highly resistant breeding sources have not been found in lettuce. The production of transgenic plants with virus-derived nucleotides is therefore an attractive alternative method. In this study we obtained transgenic lettuce with higher resistance to big-vein using the LBVaV CP gene. It is also possible to produce transgenic lettuce with resistance to big-vein using MLBVV-derived nucleotides, and this is now under investigation.

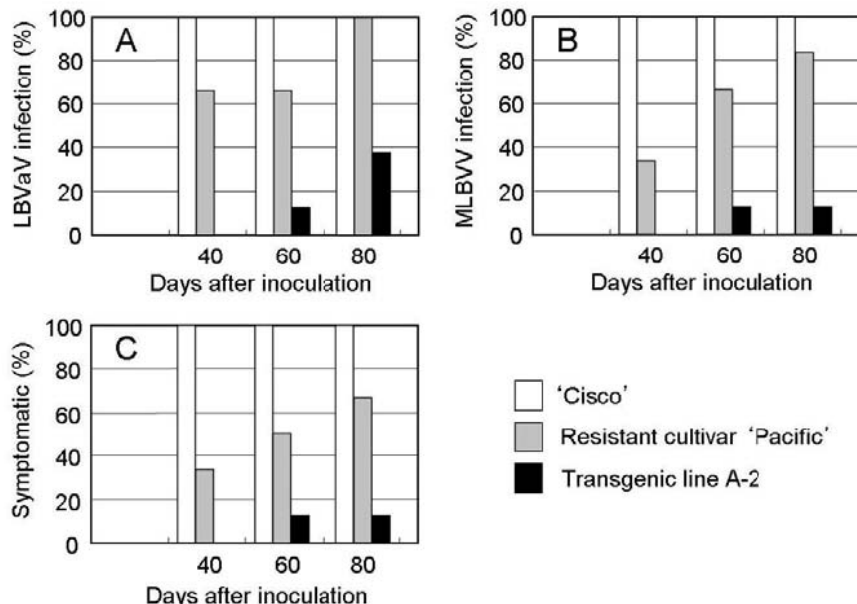

Fig. 2. Time-course of LBVaV and MLBVV infections and symptom expressions in line A-2 and two cultivars. (A) Percentage of LBVaV-positive plants. (B) Percentage of MLBVV-positive plants. (C) Percentage of symptomatic plants. Six 'Cisco' plants, 6 'Pacific' plants and 8 line A2 plants were inoculated.

References

- Bos, L., and Huijberts, N. (1990). Screening for resistance to big-vein disease of lettuce (*Lactuca sativa*). *Crop Prot* **9**, 446-452.
- Clark, M. F., and Adams, A. N. (1977). Characteristics of the microplate method of enzyme-linked immunosorbent assay for the detection of plant viruses. *J Gen Virol* **34**, 475-483.
- Edwards, K., Johnstone, C., and Thompson, C. (1991). A simple and rapid method for the preparation of plant genomic DNA for PCR analysis. *Nucleic Acids Res* **19**, 1349.
- Gallagher, S., Winston, S. E., Fuller, S. A., and Hurrell, J. G. R. (1993). Immunoblotting and Immunodetection. In: Ausubel, F. M., Brent, R., Kingston, R. E., Moore, D. D., Seidman, J. G., Smith, J. A., and Struhl, K. (ed.) *Current Protocols in Molecular Biology* UNIT 10.8.1-10.8.17, Current Protocols, USA.
- Kawazu, Y., Sasaya, T., Morikawa, T., Sugiyama, K., and Natsuaki T. (2003). Nucleotide sequence of the coat protein gene of Mirafiori lettuce virus. *J Gen Plant Pathol* **69**, 5560.
- Lot, H., Campbell, R. N., Souche, S., Milne R. G., and Roggero, P. (2002). Transmission by *Olipidium brassicae* of Mirafiori lettuce virus and Lettuce big-vein virus, and their roles in lettuce big-vein etiology. *Phytopathology* **92**, 288-293.
- Ryder, E. J., and Robinson, B. J. (1995). Big-vein resistance in lettuce: identifying, selecting, and testing resistant cultivars and breeding lines. *J Amer Soc Hort Sci* **120**, 741-746.
- Sasaya, T., Ishikawa, K., and Koganezawa, H. (2002). The nucleotide sequence of RNA1 of *Lettuce big-vein virus*, genus *Varicosavirus*, reveals its relation to nonsegmented negative-strand RNA viruses. *Virology* **297**, 289-297.

- Sasaya, T., Kusaba, S., Ishikawa, K., and Koganezawa, H. (2004). Nucleotide sequence of RNA2 of *Lettuce big-vein virus* and evidence for a possible transcription termination/initiation strategy similar to that of rhabdoviruses. *J Gen Virol* **85**, 2709-2717.
- van den Boogaart, T., Lomonosoff, G. P., and Davies, J. W. (1998). Can we explain RNA-mediated virus resistance by homology-dependent gene silencing? *Mol Plant Microbe In* **11**, 717-723.
- van der Wilk, F., Dulleman, A. M., Verbeek, M., and van den Heuvel, J. F. (2002). Nucleotide sequence and genomic organization of an *ophiovirus* associated with lettuce big-vein disease. *J Gen Virol* **83**, 2869-2877.

THE NEW FRENCH BARLEY-INFECTING FUROVIRUS IS CLOSELY RELATED TO THE JAPANESE STRAIN OF SOILBORNE WHEAT MOSAIC VIRUS

Djabbar Hariri, Michel Meyer and Maud Rivard.

PMDV, Institut National de la Recherche Agronomique (INRA), Route de Saint Cyr, 78026 Versailles Cedex, France

SUMMARY

In April 2001 during a routine examination of cereal fields in Marne province, France, we observed stunted barley plants (cv. Esterel) with mosaic symptoms typical of virus infection. Additionally, numerous resting spores of *Polymyxa graminis* have been observed in roots of these plants. Electron microscopic examinations of a sap from these plants revealed the presence of a mixture of rod-shaped and flexuous viral particles. In ELISA assays, partially-purified virus samples reacted positively with *Barley yellow mosaic virus* (BaYMV) and *Soilborne cereal mosaic virus* (SBCMV) antisera. Presence of BaYMV and a furovirus in these samples was also confirmed by the production of systemic mosaic symptoms and ELISA tests following mechanical inoculation of barley

cv. Esterel. Some plants were infected with a mixture of two viruses, whereas others only with BaYMV or the furovirus. In mechanical transmission tests, this French barley furovirus, called provisionally Soilborne barley mosaic virus, was able to infect not only *Hordeum vulgare* but also *Triticum aestivum* and *Avena sativa*. Capsid protein (CP) cistron of this furovirus was sequenced. Comparison with CP sequences of other furoviruses indicates that this French barley furovirus is closely related to the Japanese isolate of *Soilborne wheat mosaic virus* (SBWMV).

INTRODUCTION

Several furoviruses naturally infecting barley, wheat, rye and oats have been reported from different countries in Europe and other continents (Brakke, 1971; Diao et al., 1999; Koenig et al., 1999; Lapierre et al., 1985; Plumb et al., 1977; Shirako & Ehara, 1986). SBWMV, the type member of the genus *Furovirus*, occurs mostly on winter wheat in America, Europe, Asia and Africa. Based on genomic organization and biological characteristics Shirako et al. (2000) considered that the American SBWMV, Chinese wheat mosaic virus (CWMV), European SBCMV and Japanese SBWMV are four strains of the same virus species. These viruses are naturally transmitted by *Polymyxa graminis* an eukaryotic obligate biotrophic plasmodiophorid parasite of plant roots (Rao & Brakke, 1969). Genomes of these viruses are divided into two ssRNA species that are individually encapsidated. In this work we describe molecular characterisation of a new furovirus that naturally infects barley. This virus was first detected in 2001 from an infected field in Marne province, France (Hariri, 2004). The nucleotide sequence of the coat protein cistron of this virus was determined and used in phylogenetic analysis to determine its relationship to other known furoviruses. Based on these analyses and the biological data we propose to name this new virus Soilborne barley mosaic virus (SBBMV).

MATERIALS AND METHODS *Virus inoculation*

Mechanical inoculation of barley plants and other plant species were performed using crude extract from naturally infected barley leaves (*Hordeum vulgare* cv. Esterel) ground in 0.04M phosphate buffer pH 7.2. For soil inoculations seeds of barley cv. Esterel were sown in a 1:1 mixture of infected soil and sterile sand, and maintained at 15°C in a growth chamber.

For electron microscopy, leaves of diseased plants and partially purified virus preparations in 0.01 M phosphate buffer pH 7.2 were stained using 2% potassium phosphotungstate.

Enzyme-linked immunosorbent assay (ELISA)

Plant materials were ground in 0.1M citrate buffer pH 7.4 containing 0.5M urea, and Double Antibody Sandwich ELISA (DAS-ELISA) was carried out as described by Clark & Adams (1977).

Isolation of RNA, cDNA synthesis, cloning and sequencing

Total RNA was extracted from mechanically inoculated leaves of barley cv. Esterel essentially as described by Schenk et al. (1995). The first strand of cDNA was synthesized using primer sb11 (5'-TGGGCCGGATAACCCT-3'), complementary to the 3'-terminal conserved regions of RNA1 and RNA2 of SBWMV (Koenig & Huth, 2000). Two specific primers corresponding to conserved sequences immediately upstream and downstream of the capsid protein gene of furoviruses were used for PCR amplification (forward – 5'-ataagtaactgaggag-3' and reverse – 5'-atctggctctcaacttcc-3' primers). The PCR product was loaded on 1% Tris-acetate-EDTA agarose gel stained with ethidium bromide and analysed by electrophoresis. An excised gel segment of the PCR product was purified using the Qiaquick PCR Purification kit (Qiagen), and cloned into the pGEM-T-Easy vector (Promega). Plasmids were extracted from ampicillin-resistant colonies using the Quiaprep spin miniprep kit (Qiagen) and sequenced on an automated ABI Prism 310 DNA sequencer (Applied Biosystems). The nucleotide sequence obtained was analysed using the BLASTN and BLASTX algorithms at the National Centre for Biotechnology Information (<http://www.ncbi.nlm.nih.gov/Blast>). Protein comparisons were carried out using CLUSTALW program at Infobiogen.

RESULTS AND DISCUSSION

We have identified for the first time the presence of a furovirus infecting barley in Europe. This virus can also be transmitted to *Avena sativa* and *Triticum aestivum* by mechanical inoculation. More detailed analysis of the natural host range of this virus is required to determine its taxonomical position more precisely.

Electron microscopy examination of barley plants showing mosaic symptoms revealed the presence of flexuous as well as rod-shaped virus particles, suggesting presence of a bymovirus and a furovirus. However, sap from these naturally infected barley plants gave a positive reaction only with BaYMV antiserum in DAS-ELISA. Therefore, we carried out partial virus purification to achieve higher virus titre in the samples. As expected, partially purified virus preparations gave positive reaction not only with BaYMV antiserum but also with SBCMV antiserum in ELISA. These results suggested that either the concentration of the furovirus in field-infected plants is very low, or that the native form of this furovirus is serologically distinct to SBCMV.

After mechanical inoculation of barley cv. Esterel with sap from diseased plants collected in the field, many inoculated plants showed mosaic symptoms. ELISA tests showed the presence of both viruses in some of the mechanically inoculated plants. However, other individual inoculated plants contained either BaYMV or a furovirus alone.

In the roots of the plants inoculated with virus infested soil, under the controlled glasshouse conditions, numerous resting spores of *Polymyxa graminis* were present.

Partially purified furovirus preparations from barley were also tested in DAS-ELISA with polyclonal antisera against other viruses with rod-shaped particles: Soilborne rye mosaic virus (SBRMV), Aubian wheat mosaic virus (AWMV) and OGSV. All these gave negative reaction.

Mechanical inoculation of barley plants (cv. Esterel), allowed separation of SBBMV and BaYMV. Plants only infected by SBBMV were using a host range study. The comparison of behaviour of four cereals species against SBBMV and SBCMV showed only *Triticum aestivum* as a common host. Two species *Hordeum vulgare* (cv. Esterel) and *Avena sativa* were infected only with the SBBMV (Table 1). Neither of the two viruses infected *Zea Mays*.

Table 1. The plant species mechanically inoculated with SBCMV and SBBMV

Plant species	Leaf detection of the virus in ELISA	
	SBCMV	SBBMV
<i>Avena sativa</i>	0/5 ^a	1/5
<i>Hordeum vulgare</i> (cv. Esterel)	0/5	5/5
<i>Triticum aestivum</i>	5/5	1/5
<i>Zea mays</i>	0/5	0/5

^aNumber of infected plants/ number of plants tested.

Samples are considered to be positive when the OD value is equal or more than three times that of the healthy control.

An RT-PCR product of the expected size (624 bp) was amplified with SBWMV-specific primers when the total RNA from SBBMV was used as template. BLAST analysis using a sequence of this RT-PCR product revealed the highest homology with the capsid protein of a Japanese isolate of SBWMV (94,5% and 98,3% identity at the nucleotide and amino acid level, respectively). Surprisingly, this close relationship was not conserved within other isolates of SBBMV. Pairwise comparisons of CP sequence of this French barley furovirus with other furoviruses indicated that this isolate is more closely related to isolates of SBCMV present in Europe (7 to 13 amino acid differences) than to American and German isolates of SBWMV (31 amino acid differences). The most distantly related CP sequences of furoviruses were those of OGSV, CWMV and *Sorghum chlorotic spot virus* (Fig. 1). Interestingly, the amino acid changes were observed through the whole length of the capsid protein region.

Figure 1: Alignment of the amino acid sequences of different furoviruses capsid proteins

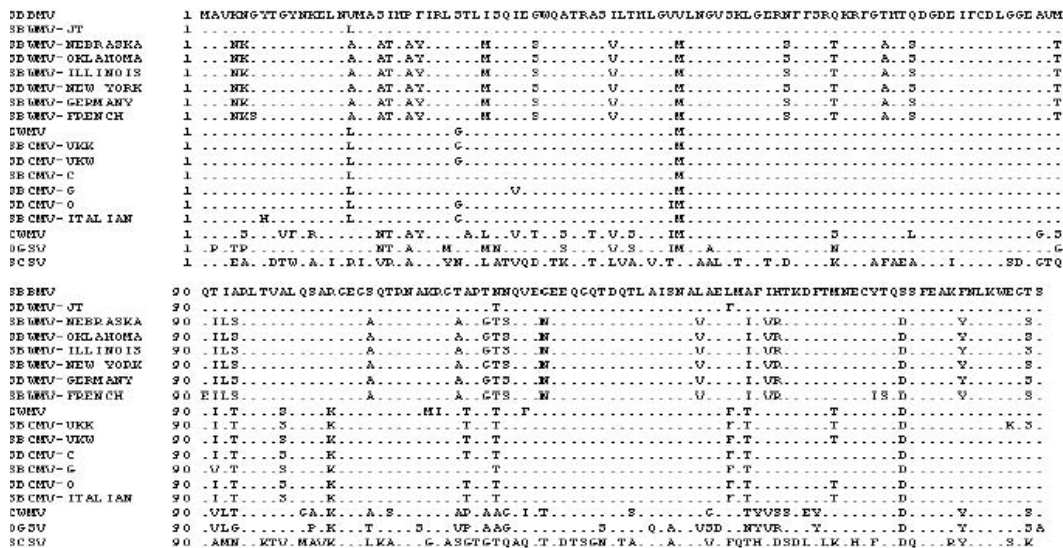

This is the first molecular data on the characterization of a novel furovirus infecting barley in Europe. The CP sequence of this virus shows good homology to the Japanese isolate of SBWMV. Additional sequence information for other genome regions of this virus is required for more precise understanding of its phylogenetic relationship with SBWMV and other furoviruses. Nevertheless, based on our preliminary molecular and biological analyses we suggest this virus is novel and it is appropriate to name it SBBMV.

ACKNOWLEDGEMENTS

We thank Dr. Morgane Guilleroux and Dr. Konstantin Kanyuka for critically reading and helpful comments on the manuscript.

REFERENCES

- Brakke, M. (1971). Soil-borne wheat mosaic virus. CMI/AAB Description of plant viruses No 77.
- Clark, M. F., and Adams, A. N. (1977). Characteristics of the microplate method of enzyme-linked immunosorbent assay for the detection of plant viruses. *J Gen Virol* **34**, 475-483.
- Diao, A., Chen, J., Ye, R., Zheng, T., Yu, S., Antoniw, J. K., Adams M. J. (1999). Complete sequence and genome properties of Chinese wheat mosaic virus, a new furovirus from China. *J Gen Virol* **80**, 1141-1145.
- Hariri, D. (2004). Soil-borne barley mosaic. Viruses and virus diseases of *Poaceae* (*Gramineae*). H. Lapierre, P-A. Signoret, Editions INRA.
- Koenig, R., Pleij, C. W. A., Huth, W. (1999). Molecular characterization of a new furovirus mainly infecting rye. *Arch Virol* **144**, 2125-2140.
- Koenig, R., Huth, W. (2000). Soil-borne rye mosaic and European wheat mosaic virus: two names for a furovirus with variable genome properties which is widely distributed in several cereal crops in Europe. *Arch Virol* **145**, 689-697.
- Lapierre, H., Courtillot, M., Kusiak, C., Hariri, D. (1985). Résistance au champ des blés en semis d'automne au virus de la mosaïque du blé (wheat soil-borne mosaic virus). *Agronomy* **5**, 565-572.
- Mirza, I. H., Wilkin, T. J., Cantarini, M., Moote, M (1987). A comparison of spleen and lymph node cells as fusion partners for the raising of monoclonal antibodies after different routes of immunization. *J Immunol Methods* **105**, 235-243.
- Plumb, R., Catherall, P. L., Chamberlain, J. A., MacFarlane, I. (1977). A new virus in oats in England and Wales. *Ann Phytopathol* **9**, 365-370.
- Rao, A. S., Brakke, M. K. (1969). Relation of soil-borne wheat mosaic and its fungal vector *Polymyxa graminis*. *Phytopathology* **59**, 581-587.
- Schenk, P. M., Antoniw, J. F., deBatista, M., Jacobi, V., Adams, M. J., Steinbiss, H. H. (1995). Movement of barley mild mosaic and barley yellow mosaic viruses in leaves and roots of barley. *Ann Appl Biol* **120**, 291-305.
- Shirako, Y., Ehara, Y (1986). Comparison of the in vitro translation products of wild-type and a deletion mutant of soil-borne wheat mosaic virus. *J Gen Virol* **67**, 1237-1245.
- Shirako, Y., Suzuki, N., French, R. C. (2000). Similarity and divergence among viruses in the genus *Furovirus*. *Virology* **270**, 201-207.

FREESIA LEAF NECROSIS: A NEW OPHIOVIRUS INVOLVED

A.M. Vaira¹, V. Torok², G.P. Accotto¹, S. Rapetti³, M. Vecchiati¹, V. Masenga¹, H.J. Vetten⁴ and R.G. Milne¹

¹Istituto di Virologia Vegetale – CNR – Strada delle Cacce 73 10135 Torino, Italy;

²SARDI - Field Crops Pathology Unit, Plant Research Centre, GPO Box 397, Adelaide SA 5001, Australia;

³Istituto Regionale per la Floricoltura, Via Carducci 12, 18038 Sanremo, Italy;

⁴Biolog. Bundesanstalt f. Land- u. Forstwirtschaft, Dept. of Plant Virology, Microbiology and Biosafety, Messeweg 11-12, 38104 Braunschweig, Germany

Summary

A new Ophiovirus is likely involved in freesia leaf necrosis disease. It was identified by RT-PCR using ophiovirus-specific primers and by electron microscopy. The viral coat protein ORF was cloned and sequenced and the protein showed less than 50% identity with analogous sequences of three other ophiovirus species. The presence of ophiovirus-like particles in field samples was fairly correlated to the presence of necrotic symptoms. The viral infection was soil-transmitted to healthy freesia seedlings. The name Freesia sneak virus (FreSV) is proposed for this new ophiovirus species infecting freesia.

Introduction

Ophioviruses (Vaira *et al.*, 2005) have ssRNA genomes that are of negative polarity and divided into three to four individually encapsidated segments; they share genome organization and particle morphology (unenveloped, circularized, coiled or kinky filaments, Fig. 1). The genus *Ophiovirus* currently comprises five species: *Citrus psorosis virus* (CPsV), *Ranunculus white mottle virus* (RWMV), *Tulip mild mottle mosaic virus* (TMMMV), *Mirafiori lettuce big-vein virus* (MLBVV) and *Lettuce ring necrosis virus* (LRNV). Natural transmission, established for TMMMV, MLBVV and LRNV, involves zoospores of the fungus *Oplidium brassicae*.

Necrotic disorders of freesia, also referred to as freesia leaf necrosis and thought to be spread by *Oplidium brassicae*, have been known in the Netherlands, England and Germany since 1970 (Verbeek *et al.*, in press; Bouwen 1994; Brunt *et al.*, 1996; Casper and Brunt 1971; van Dorst 1975, van Dorst 1973) but have also been reported from south east Asia. Freesias grown in northern Italy have also shown leaf necrosis symptoms causing severe losses (Vaira *et al.*, in press). Several agents have been found associated with the disease (Bellardi and Bertaccini, 1989), such as the potyviruses *Bean yellow mosaic virus* and *Freesia mosaic virus*, varicosavirus-like particles previously referred to as Freesia leaf necrosis virus, and an ophiovirus-like virus (Vaira *et al.*, in press). The latter is here provisionally named Freesia sneak virus (FreSV) owing to an ability to introduce itself without detection, at least until recently, leaving telltale EM images and an ophiovirus-specific RT-PCR footprint (Vaira *et al.*, 2003).

Materials and Methods

Electron microscopy techniques, RT-PCR parameters, and virus transmission through the soil are described (Vaira *et al.*, in press). FreSV CP clones were obtained by RT-PCR using suitable primers (Torok and Vetten personal communication) and by primer walking and cloning using the Universal RiboClone cDNA Synthesis System (Promega). DNAMAN (Lynnon Corp.)

software was used for sequence assembly and analysis. EMBOSS Align (EBI website) was used for protein sequence alignments, using default parameters.

Results and Discussion

Amplification of a 136 bp fragment by RT-PCR and OP-1/OP-2 primers (Vaira *et al.*, 2003) was obtained with all five established ophiovirus species but not with species in other genera such as *Nucleorhabdovirus*, *Cytorhabdovirus*, *Tenuivirus*, *Tospovirus* and *Varicosavirus*, all genera that, for different reasons, have been considered to share affinity with ophioviruses. Total RNA extracted from FreSV-infected freesia was used as template for this same RT-PCR and the expected 136 bp fragment was easily amplified. A small digoxigenin-labelled DNA probe was obtained by PCR using the 136 bp fragment amplified from infected freesia. This was successfully hybridized in Southern blots with the 136 bp fragments amplified from other ophioviruses, proving sequence similarity (Vaira *et al.*, in press). Thus FreSV is an ophiovirus.

Attempts at soil transmission of FreSV were successful. After two years, 6 healthy freesia seedlings grown in contaminated soil and 12 grown in sterilized soil were tested by RT-PCR to check for FreSV infection. All plants from the contaminated soil were found infected and all those grown in sterilized soil were not infected (Vaira *et al.*, in press). Thus FreSV is soil-transmitted. However, the soil-inhabiting agent responsible for this transmission was not studied and identified.

Correlation between FreSV infection and necrotic symptoms on freesia plants was good but not conclusive; about half of the 75 necrotic samples analyzed by EM during four years contained ophiovirus-like particles while no such particles were seen in any of the 27 non-necrotic samples analyzed (Vaira *et al.*, in press). When a more sensitive technique such as RT-PCR was used, nine out of nineteen plants showing leaf necrosis were ophiovirus-positive.

The complete nucleotide sequence of FreSV coat protein was amplified from cDNA using *Pfu* polymerase. The source of total RNA was a field-grown freesia plant collected during winter 2005 in Sanremo (Liguria, Northern Italy). The primers used were derived from the sequences previously obtained from different partial clones. The 1305 bp fragment was cloned into pBluescript KS+ and sequenced. When a FreSV CP-specific probe was used in Northern blot to target the viral RNA segments present in total RNA extracts from FreSV-infected freesia, a molecule of about 1.5 kb was labelled, suggesting that RNA 3 contains the CP ORF. The predicted CP amino acid sequence was obtained and its deduced molecular weight is 48.4 kDa. Ophiovirus CP sequence alignments revealed that FreSV shares identities (similarities) of 48.8% (70.5%) with MLBVV, 49% (68.5%) with LRNV, and 30.6% (53.9%) CPsV.

Our data provide evidence that FreSV is a new soilborne ophiovirus species infecting freesia. As FreSV always occurred together with other viruses in freesia and experimentally infected freesias did not reproduce typical necrotic streaks similar to those in field-grown plants (Vaira *et al.*, in press), its role in the leaf necrosis disease remains unclear.

Fig. 1 Electron microscopy image of Ophiovirus-like particles in crude freesia sap, 1% uranyl acetate.

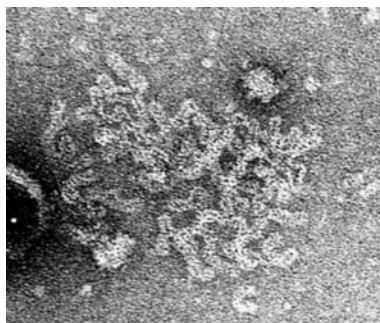

References

- Bellardi, M.G. and Bertaccini, A. (1989). Virus diseases of Freesia in Italy. *Advances in Horticultural Science* **3**,29-32.
- Bouwen, I. (1994). Freesia leaf necrosis: Some of its mysteries revealed. *Acta Horticulturae* **377**,311-318.
- Brunt, A.A., Crabtree, K., Dallwitz, M.J., Gibbs, A.J. and Watson, L. (eds). (1996). *Viruses of Plants*. CAB International, Wallingford, UK
- Casper, R. and Brunt, A.A. (1971). Freesia streak virus, a new freesia virus in Germany. *Nachrichtenblatt des Deutschen Pflanzenschutzdienstes* **23**,89-90.
- Vaira A.M. et al. Ophiovirus. In *Virus Taxonomy – Eighth Report of the International Committee on Taxonomy of Viruses* (2005). Edited by C.M. Fauquet et al. Academic Press.
- Vaira, A.M., Accotto, G.P., Costantini, A. and Milne R.G. (2003). The partial sequence of RNA 1 of the Ophiovirus *Ranunculus white mottle virus* indicates its relationship to rhabdoviruses and provides candidate primers for an ophiovirus-specific RT-PCR test. *Arch. Virol* **148**,1037-1050.
- Vaira A.M., Lisa V., Costantini A., Masenga V., Rapetti S. and R.G. Milne. Ophioviruses infecting ornamentals and a probable new species associated with a severe disease in freesia. *Acta Horticulturae* (in press).
- van Dorst, H.J.M. (1975). Evidence for the soil-borne nature of freesia leaf necrosis virus. *Neth. J. Plant Pathol.* **81**,45-48.
- van Dorst, H.J.M.. (1973). Two new diseases in freesia. *Neth. J. Plant Pathol* **79**,130-137.
- Verbeek, M., Lindner, J., Bowen, I, Dullemans, A. and van der Vlugt R. An ophiovirus isolated from freesia with freesia leaf necrosis disease. *Acta Horticulturae* in press.

CHARACTERISTICS OF DIFFERENTIAL HOST SPECIES FOR DISTINGUISHING BEET NECROTIC YELLOW VEIN VIRUS ISOLATES OF DIFFERENT PATHOGENICITY

Tetsuo Tamada and Kazuyuki Maruyama

Research Institute for Bioresources, Okayama University, Kurashiki, 710-0046, Japan.

Summary

Beet necrotic yellow vein virus (BNYVV), responsible for rhizomania disease of sugar beet, is transmitted by the soilborne fungus *Polymyxa betae*. It is difficult to estimate the pathogenicity (symptom severity and virulence) of BNYVV isolates (strains), because the virus is usually confined to the roots and induces no obvious symptoms. Here, we have selected differential plant species for distinguishing BNYVV isolates by foliar rub-inoculation and fungus inoculation. The host species (infection phenotypes) are as follows: *Tetragonia expansa* (local lesion phenotype), *Beta vulgaris* spp. *maritima* MR0, MR1 and MR2 (local lesion phenotypes), *B. vulgaris* spp. *maritima* M8 (systemic symptoms), *B. macrocarpa* (systemic symptoms), and *Nicotiana benthamiana* (systemic symptoms). These plant species are useful for distinguishing BNYVV isolates of different pathogenicity that is especially controlled by three small RNA species RNA3 (P25), RNA4 (P31) and RNA5 (P26).

Introduction

Beet necrotic yellow vein virus (BNYVV) is responsible for rhizomania disease of sugar beet and is transmitted by the soilborne fungus *Polymyxa betae*. RNA1 and RNA2 encode "house-keeping" genes involved in replication, assembly and cell-to-cell movement, whereas RNA3, RNA4 and RNA5 are associated with vector-mediated infection and disease development in sugar beet roots (Tamada, 1999). RNA3 has major effects on rhizomania symptoms. RNA4 needs for efficient transmission by the fungus. RNA5 is found only in limited areas and is associated with disease development (Tamada, 1999). Although no serological differences are found among virus isolates, the majority have been classified into A and B types based on sequence differences (Kruse *et al.*, 1994; Koenig *et al.*, 1995). Furthermore, French RNA5-containing isolates were classified as the P type (Koenig *et al.*, 1995), which is more closely related to the A type (Miyaniishi *et al.*, 1999). RNA5-containing isolates were more virulent than RNA5-lacking isolates (Heijbroek *et al.*, 1999). In field-infected sugar beet, BNYVV is usually confined to the roots and induces no obvious foliar symptoms. Additionally, root symptoms are greatly affected by plant stage, inoculum potentials and environmental conditions. Thus, estimation of BNYVV isolates (strains) with different pathogenicity is important, but laborious and time-consuming. Here, we have selected differential plant species by foliar rub-inoculation and fungal inoculation, and describe the phenotypes produced in those plant species by infections of BNYVV isolates containing different RNA components.

Materials and Methods

Plant materials and virus isolates

Tetragonia expansa, *Beta vulgaris* spp. *maritima* M8, MR1 and MR2 (called *B. maritima* M8, MR1 and MR2), *B. macrocarpa*, and *Nicotiana benthamiana* were used. These plants were grown in a growth cabinet or a greenhouse. BNYVV field isolates, O11, S113, T41, GW, T104, S44, and FP and laboratory isolates, O11-0, O11-3, O11-4, O11-3d4, T104-5, and T104-45 were used (Table 1). The laboratory isolates were obtained by single-lesion isolation as described previously

(Tamada *et al.*, 1989). RNA components included in these isolates are shown in Table 1.

Virus inoculations

For foliar rub-inoculation, virus-infected leaves were ground in distilled water and the sap was rubbed onto Carborundum-dusted leaves of plants. Fungus inoculation was conducted as described previously (Tamada and Kusume, 1991). Viruliferous zoospore suspension derived from fungus-infested sugar beet roots was obtained by collecting waste drained from the bottom hole of the test tubes into which nutrient solution had been poured. Inoculated plants were kept in a growth cabinet at 24 °C. Virus infection in roots was confirmed by ELISA.

Results and Discussion

Infection phenotypes by foliar lab-inoculation

BNYVV is transmitted by foliar rub-inoculation to most species of the family Chenopodiaceae and several species belonging to the Aizoaceae, Amaranthaceae, Caryophyllaceae and Solanaceae (Tamada, 1999). In general, the virus tends to be restricted to the inoculated leaves of many host plants, but moves systemically in a few plant species. We have selected *T. expansa* and *M. maritima* MR0, MR1 and MR2 for local lesion hosts and *B. maritima* M8, *B. macrocarpa* and *N. benthamiana* for systemic hosts.

T. expansa: As described previously (Tamada *et al.*, 1989), different strains of the virus are characterized on the basis of the type of local lesions in this species: YS (bright yellow spots), CS (chlorotic spots), fCS (faint chlorotic spots), and NS (necrotic spots) (Table 1). These symptoms depend on the presence of RNA3, RNA4 and/or RNA5, or their deletion mutants (Table 1). For examples, RNA3-containing isolates induced YS type symptoms, whereas RNA3-lacking

Table 1. Phenotypes produced in differential plant species by infections of BNYVV isolates containing different RNA components

BNYVV (origin)	Type	Small RNA species			<i>T. expansa</i>			<i>B. maritima</i>			<i>B. macrocarpa</i>		<i>N. benthamiana</i>
		RNA3	RNA4	RNA5	MR0	MR1	MR2	M8					
Field isolates													
O11 (Japan)	A	+	+	-	YS	NS	NS	S(+++)	S(+++)	S(+++)	S(+++)	S(++)	
S113 (Japan)	A	+	+	-	YS	YS	NS	S(+++)	S(+++)	S(+++)	S(+++)	S(++)	
T41 (Japan)	A	+	+	-	YS	YS	YS	S(+++)	S(+++)	S(+++)	S(+++)	S(++)	
GW (Germany)	B	+	+	-	YS	YS	YS	S(+++)	S(+++)	S(+++)	S(+++)	S(++)	
T104 (Japan)	A	+	+	+	YS+NS	NS	NS	S(+++)	S(+++)	S(+++)	S(+++)	S(++)	
S44 (Japan)	A(?)	+	+	+	YS	NS	NS	S(+++)	S(+++)	S(+++)	S(+++)	S(++)	
FP (France)	A(P)	+	+	+	YS+NS	YS	NS	S(+++)	S(+++)	S(+++)	S(+++)	NT	
Laboratory isolates													
O11-0	A	-	-	-	fCS	fCS	fCS	-	-	-	-	S(+)	
O11-3	A	+	-	-	YS	NS	NS	S(++)	S(++)	S(++)	S(++)	S(+)	
O11-4	A	-	+	-	CS	fCS	fCS	-	-	-	-	S(++)	
O11-3d4	A	+	+	-	CS	fCS	fCS	-	-	-	-	NT	
T104-5	A	-	-	+	CS	CS	CS	S(+)	S(+)	S(+)	S(+)	NT	
T104-45	A	-	-	+	CS+NS	CS	CS	S(+)	S(+)	S(+)	S(+)	NT	

The presence of small RNA species: +, presence; -, absence; d, deletion mutant

Phenotypes on inoculated leaves as follows: YS, bright yellow spots; fCS, faint chlorotic spots; CS, chlorotic spots; NS, necrotic spots.

Phenotypes of systemic infection as follows: S, systemic infection (severity: + to +++); -, no systemic infection; NT, not tested.

or deleted mutant viruses produced CS type lesions. Isolates that contain RNA5 but lack RNA3 cause severe CS type lesions. Thus, this plant species is most useful for distinguishing virus isolates of different pathogenicity.

B. maritima MR0, MR1, and MR2: These plant lines were selected *B. maritima* accessions (Tamada *et al.*, 1999). The resistance and susceptibility of BNYVV isolates can be evaluated on the basis of phenotypes on the inoculated leaves (Table 1). For examples, O11 isolate produced the NS phenotype (refers to resistance response) in the inoculated leaves of MR1 and MR2 plants. S113 isolate produced the NS phenotype in MR2 plants, and the YS phenotype (refers to susceptible response) in MR1 plants. T41 and GW isolates produced the YS phenotype on MR1 and MR2 plants. MR0 plants inoculated with all field isolates developed the YS phenotype. These phenotypes were determined by a single amino acid change at position 68 of the P25 protein (Chiba *et al.*, 2002). Thus, these *B. maritima* lines are useful hosts for distinguishing the specificity (virulence or avirulence) of the P25 protein that contained in BNYVV isolates.

B. maritima M8: Plants inoculated with field isolates (O11, S113, T41, and GW) developed YS symptoms in the inoculated leaves, followed by severe systemic yellow mosaic with severe stunting (Table 1). However, some RNA5-containing isolates (T104 and FC) produced YS and NS symptoms, but other RNA5-containing isolates (S44) produced only YS symptoms, and thus necrotic responses in this host depended on virus isolates. This suggests that there are specificity (virulence or avirulence) between RNA5 sequences and this plant species. Isolates with RNA3 and/or RNA5 caused systemic symptoms, indicating that either RNA3 or RNA5 is essential for systemic infection (Table 1). RNA3-containing isolate (O11-3) produced more severe stunting symptoms than RNA5-containing isolate (T104-5). Severely stunted plants died within one month after inoculation and this is also depending on stunting. This plant species can be useful for estimating the pathogenicity (such as vascular movement) of BNYVV isolates.

B. macrocarpa: When inoculated with wild-type BNYVV, YS symptoms appeared in inoculated leaves, followed by systemic yellow mosaic or yellow flecks with severe stunting (Tamada *et al.*, 1989). Like *B. maritima* M8, systemic infection in this host is RNA3-dependent or RNA5-dependent (Table 1). RNA3-containing isolates induced more severe stunting symptoms than RNA5-containing isolate. However, systemic symptoms in this species were much milder than those in *B. maritima* M8. This plant species also can be useful for estimating the pathogenicity (such as vascular movement) of BNYVV isolates.

N. benthamiana: This plant species develops systemic infection for which RNA1 and RNA2 are required, unlike *B. macrocarpa* and *B. maritima* M8 (Table 1). Until 12 to 14 days after inoculation, upper, non inoculated leaves showed a downward curling and stunting, following faint and then severe mosaic symptoms (Andika *et al.*, 2005). There were no significant differences in symptom severity among field isolates. However, RNA4-lacking isolates showed milder symptoms. This plant species is useful for investigating biological and molecular functions of virus genome and host factors. Plant transformation systems are easily established.

Infection phenotypes by fungal inoculation

Sugar beet (*Beta vulgaris* spp. *vulgaris*) seedlings are useful for testing transmission by the vector (Tamada, 1999). Symptoms are characterized by pale green leaves and abnormal growth of lateral roots. These symptoms usually appear one to two months after fungal inoculation. In this study, we selected *B. maritima* M8 and *B. macrocarpa*. When roots of *B. maritima* M8 plants were inoculated with field isolates by the viruliferous fungus, chlorosis appeared on upper, developing leaves at about two weeks after virus inoculation. Three weeks later, upper leaves became yellow and plants were stunted. In some cases, virus moved systemically into shoots within one to two months and these plants eventually died. *B. macrocarpa* plants inoculated with field isolates developed pale green symptoms on upper leaves about three weeks after inoculation. Yellowing symptoms became much stronger by one to two months, but usually the virus failed to move systemically. RNA3-lacking isolates (O11-4 and T104-45) or RNA3 deletion

mutant isolate (O11-3d4) failed to produce any yellowing symptoms in *B. macrocarpa*, although they produced faint chlorosis in upper leaves of *B. maritima* M8 plants. Thus, BNYVV RNA3 is strongly involved in the development of yellowing symptoms. These two plant species are useful for estimating the pathogenicity of BNYVV isolates by fungal inoculation. In addition, *B. macrocarpa* is useful as a bait plant for the fungus transmission.

References

- Andika, I. B., Kondo, H. and Tamada, T. (2005). Evidence that RNA silencing-mediated resistance to *Beet necrotic yellow vein virus* is less effective in roots than in leaves. *Mol. Plant-Microbe Interact.* **18**, 194-204.
- Chiba, S., Miyanishi, M., Kondo, H. and Tamada, T. (2002). Single amino acid changes in the P25 protein gene of *Beet necrotic yellow vein virus* determine resistance responses in *Beta vulgaris* spp. *maritima*. Proc. Symp. 5th Int. Working Group on Plant Viruses with Fungal Vectors. Zurich, July 22-25. p. 5-8.
- Heijbroek, W., Musters, P. M. S. and Schoone, A. H. L. (1999). Variation in pathogenicity and multiplication of beet necrotic yellow vein virus (BNYVV) in relation to the resistance of sugar-beet cultivars. *Europ. J. Plant Pathol.* **105**, 397-405.
- Koenig, R., Luddecke, P. and Haerberle, A. M. (1995). Detection of beet necrotic yellow vein virus strains, variants and mixed infections by examining single-strand conformation polymorphisms of immunocapture RT-PCR products, *J. Gen. Virol.* **76**, 2051-2055.
- Kruse, M., Koenig, R., Hoffmann, A., Kaufmann, A., Commandeur, U., Solovyev, A. G., Savenkov, I. and Burgermeister, W. (1994). Restriction fragment length polymorphism analysis of reverse transcription-PCR products reveals the existence of two major strain groups of beet necrotic yellow vein virus. *J. Gen. Virol.* **75**, 1835-1842.
- Miyanishi, M., Kusume, T., Saito, M. and Tamada, T. (1999). Evidence for three groups of sequence variants of beet necrotic yellow vein virus RNA 5. *Arch. Virol.* **144**, 879-892.
- Tamada, T. (1999). Benyviruses. In: Encyclopedia of Virology. Second Edition. R. G. Webster and A. Granoff, eds. Academic Press, London. p. 154-160.
- Tamada, T., Shirako, Y., Abe, H., Saito, M., Kiguchi, T. and Harada, T. (1989). Production and pathogenicity of beet necrotic yellow vein virus with different numbers of RNA components. *J. Gen. Virol.* **70**, 3399-3409.
- Tamada, T., Miyanishi, M. and Takemoto, M. (1999). Involvement of beet necrotic yellow vein virus RNA 3 in restricted virus multiplication in resistant lines of *Beta vulgaris* ssp. *maritima*. Proc. Symp. 4th Int. Working Group on Plant Viruses with Fungal Vectors. Monterey. October 5-8. p.127-130.

INVOLVEMENT OF *BEET NECROTIC YELLOW VEIN VIRUS* RNA 4 IN SYMPTOM EXPRESSION IN *NICOTIANA BENTHAMIANA*

Muhammad Danial Rahim, Ida Bagus Andika, Cheng Gui Han, Hideki Kondo and Tetsuo Tamada

Research Institute for Bioresources, Okayama University, Kurashiki, 710-0046 Japan.

Summary

Beet necrotic yellow vein virus (BNYVV) consist of four RNA genomes. RNA 1 and RNA 2 are involved in replication, cell to cell movement and virus assembly. RNA 3 is required for symptom development in sugar beet roots, whereas RNA 4 is important for efficient transmission by fungus vector. BNYVV can readily cause systemic infection in *Nicotiana benthamiana*, showing severe leaf curling and stunting of plants. Wild-type or RNA 4-containing virus isolates produced severe symptoms, whereas RNA 4-lacking isolates showed mild symptoms, suggesting that RNA 4 was associated with expression of severe symptoms. RNA 3 was not associated with severe symptoms. Mutagenic analysis revealed that P31-ORF is required for severe symptoms. No significant differences were found in viral and RNA accumulation between systemic, upper leaves showing severe and mild symptoms. Transgenic plants with P31-ORF did not show any morphological abnormality. P31-ORF silencing plants inoculated with wild-type virus displayed mild symptoms. These result indicate that entire RNA 4 is involved in severe symptoms in *N. benthamiana*.

Introduction

Beet necrotic yellow vein virus (BNYVV, genus : *Benyvirus*) causes rhizomania disease of sugar beet and is transmitted by the soil-inhabiting fungus, *Polymyxa betae* (Tamada, 1999). BNYVV has a multipartite genome and consists generally of four, or in some isolates, five distinct RNA species, referred to as RNA 1 to RNA 5 (Richards and Tamada, 1992). RNA 1 and RNA 2 encode functions for viral RNA replication, cell to cell movement, and virus assembly, and are necessary for infection of leaves by mechanical inoculation. RNA3 is required for symptom development in sugar beet roots, while RNA 4 is important for efficient transmission of the virus by fungus vector (Tamada and Abe, 1989). It has been shown that RNA 3 has a dramatic effect on symptoms for leaf infection (Tamada *et al.*, 1989). Virus isolates containing RNA 3 produced bright yellow lesions in *Tetragonia expansa* or *Chenopodium quinoa*, whereas, in absence of RNA 3, isolates containing RNA 4 produced stronger chlorotic lesions than those lacking RNA 4 that produced only faint chlorotic lesions. This suggests that RNA 4 has a slight effect on lesion phenotype, although this effect is smaller than RNA 3 effect.

Host range of BNYVV is restricted in most species of the family Chenopodiaceae and several species belonging to the Aizoaceae, the Amaranthaceae and the the Solanaceae. Usually, the virus tends to be restricted to inoculated leaves of most host plants. However, the virus can easily move from inoculated to upper, noninoculated leaves of *Beta macrocarpa* and *Spinacia oleracea* (Tamada, 1999). BNYVV RNA 3 is required for systemic infection in *B. macrocarpa*, but is not required in *S.oleracea* (Tamada *et al.*, 1989; Lauber *et al.*, 1998). In addition, the virus can infect systemically *Nicotiana benthamiana*, causing leaf curling and stunting of plants (Andika *et al.*, 2005). Here, we examined the influences on RNA 3 and RNA 4 on the symptoms expression in *N. benthamiana*. The result shows that RNA 4 is involved in development of severe symptoms in this host species.

Materials and methods

Plant materials

T. expansa, wild-type and transgenic *N. benthamiana* plants carrying the 35S promoter : 31-kDa-ORF (P31-ORF) sequence were used. P31-ORF-transgenic plants were produced by Agrobacterium-mediated transformation (Andika *et al.*, 2005).

Virus isolates

The wild-type BNYYY isolates O11 (RNA 1 + 2+ 3+ 4) and the laboratory isolate O11-0 (RNA 1 + 2), O11-3 (RNA 1 + 2 + 3) and O11-4 (RNA 1 + 2 + 4) were used. These isolates were obtained from original isolate O11 by single lesion transfer in *T. expansa* leaves. The wild-type and mutant viruses were propagated in inoculated leaves of *T. expansa*.

cDNA clones, infectious transcripts, and inoculations

DNA manipulation and cloning were carried out using standard procedures by Sambrook *et al.* (1989). Full-length infectious clones cDNA of RNA 4 from BNYYV-O11 were amplified by RT-PCR methods. PCR products were ligated to pGEM-T vector, and positive clone was named pGTOF1. The pGTOF1 clone was subcloned into the *Hind*III and *Xba*I restriction site of pUC19 to obtained pUOF1-6.

Full-length clone of pUOF1-6 under control of a bacteriophage T7 RNA polymerase promoter, were used for mutagenesis. PCR-based, site directed mutagenesis was applied for generation of mutant constructs. Six mutants were obtained : Δ CCG, Δ MD-1, Δ MD-2, Δ MD-3, Δ C-ter, Δ ORF, which contained deletion of all or parts of P31-ORF and a codon change (Fig. 1).

In vitro transcripts from each of the cDNA clones and RNAs from isolate O11-0 were co-inoculated onto *T. expansa* leaves. Inoculation was conducted as described previously (Andika *et al.*, 2005).

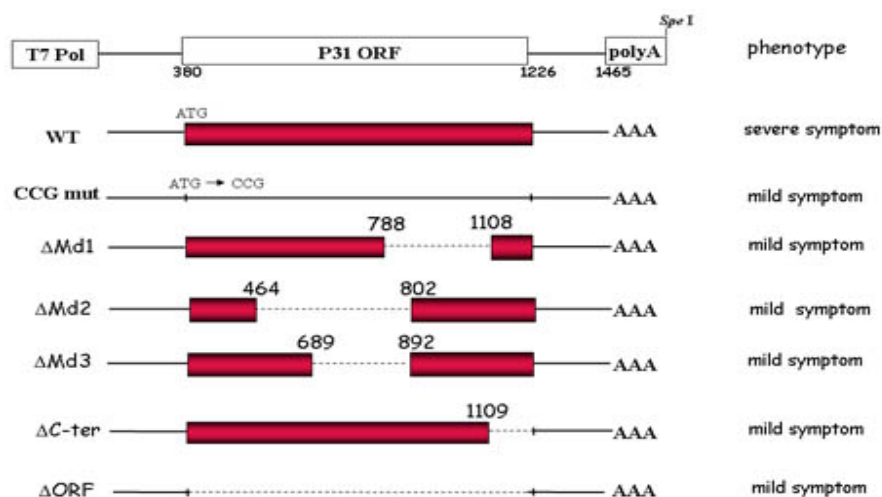

Figure 1. Genetic map of BNYVV RNA 4 mutants and symptom phenotypes in *N. benthamiana*.

ELISA, tissue imprinting, RT-PCR and RNA blot

BNYVV infection, virus content and viral RNA accumulation in inoculated leaves were conducted by ELISA, tissue imprinting assay, RT-PCR and Northern blot as described previously (Andika *et al.*, 2005). For amplification of viral RNA, forward primer 31K-N (5'-CTGATTAGTAACACATATGGCTGA-3') and reverse primer 31K-B (5'-TAAACACATCATGGATCCCACTAG-3') were used

Results and discussion

Symptom expression in N. benthamiana

When BNYVV O11 isolate was rub-inoculated into leaves of *N. benthamiana* seedlings, a downward curling of the upper leaves appeared at 10 to 12 days after inoculation. Infected plants were then stunted and the curling leaves that first appeared gradually wilted. Inoculated leaves also wilted and eventually died. About three weeks after inoculation, the symptom became mild (recovered), followed by severe mosaic with a leaf distortion. This is a characteristic symptom to BNYVV infection in *N. benthamiana*, but much milder symptoms were observed occasionally. Infected plants were not stunted and showed no mosaic symptoms, but in some cases, infected plants displayed slight mottle symptoms.

To understand this symptom difference, the influence of RNA 3 and RNA 4 on the symptom expression was examined. When 20 *N. benthamiana* seedlings were rub-inoculated with O11 isolate, 15 and 5 plants displayed severe and mild symptoms, respectively. RNA 4 was detected by RT-PCR in all 15 plants that showed severe symptoms, but not in the 5 plants that showed mild symptoms. RNA 3 was detected from only 4 plants, irrespective of the presence of RNA 4. When the sap of RNA 3-detected leaves obtained in this experiment as inoculum was again inoculated to *N. benthamiana* seedlings, RNA 3 was detected in only a few plants (3 out of 15 plants). These results indicate that RNA 3 may be eliminated at an initial infection process or disappear spontaneously during virus propagation in *N. benthamiana*.

To further confirm the effects of RNA 3 and RNA 4, laboratory isolates (O11-0, O11-3 and O11-4) containing different RNA species were inoculated into *N. benthamiana*. The result showed that O11-4 induced severe symptoms in *N. benthamiana*, whereas O11-0 and O11-3 produced mild symptoms, although some of O11-3 infected plants contain RNA 3, but other did not contain it. No differences in symptom expression were found between plants infected with O11 and O11-4 or O11-0 and O11-3. Northern blotting test revealed that no significant differences in levels of RNA accumulation were found between leaf tissues of plants showing severe symptoms and mild symptoms. No differences in viral accumulation was also confirmed by tissue imprinting assay and ELISA tests. These results indicate that RNA 4 is associated with severe symptoms in *N. benthamiana*, but RNA 3 is not.

P31-ORF is required for expression of severe symptoms

To determine the locus on the RNA 4 sequence responsible for symptom phenotype, mutations engineered into RNA 4 at the cDNA level and synthetic RNA transcripts were obtained. In all experiments, the obtained transcripts and RNAs (RNA 1 and RNA 2) extracted from O11-0 infected leaves were mixed and inoculated into *T. expansa* leaves, and the sap of the infected leaves was inoculated into *N. benthamiana* seedlings. The results revealed that deletions (nt788-1108 or Δ MD-1, nt698-892 or Δ MD-2, nt464-802 or Δ MD-3, nt1109-1225 or Δ C-ter, and nt380-1225 or Δ ORF) which eliminated all or parts of the P31-ORF abolished the severe symptom phenotype (Fig. 1). A similar result was obtained by interrupting the P31 cistron by transformation of the P31 AUG initiation codon by CCG (Δ CCG) (Fig. 1). Northern blotting tests showed that no differences at levels of RNA accumulation were found between

wild-type O11-4 and mutant viruses. These results indicate that the P31-ORF is required for expression of severe symptoms.

Analysis using transgenic plants expressing the P31-ORF sequences

To examine the effect of the P31-ORF sequence on severe symptom expression in *N. benthamiana*, transgenic *N. benthamiana* plants expressing the P31-ORF sequence were produced by agrobacterium-mediated transformation. Transformed and regenerated plants of *N. benthamiana* were self-pollinated, and the T1 progeny from each line were screened for resistance to kanamycin. Total 20 transgenic lines were produced and subjected for Northern blotting tests. Levels of expression of transgene transcripts varied with transgenic lines. Some lines showed morphological abnormal, but they were not associated with levels of transgene. Two lines (R4-6 and R4-8) that showed relatively high levels of transgene mRNA and also two lines (R4-7 and R4-10) that showed a low level of transcripts were used for BNYVV inoculation. Two lines (R4-6 and R4-8) inoculated with O11-4 displayed severe symptoms which were similar to nontransgenic plants inoculated with O11-4. In addition, O11-0 produced mild symptoms in these transgenic plants, suggesting no cis-acting effect from the transgene P31-ORF sequence. On the other hand, interestingly, most plants from one line (R4-7) inoculated with O11-4 developed mild symptom phenotype which is similar to plants inoculated with O11-0. Northern blotting revealed that there were no or only low levels of virus-derived RNA 4 accumulation in BNYVV-infected plants. These result indicate that the P31 ORF gene in the R4-7 plant line is silenced. This was also confirmed by a PCR-based technique employing methylation-sensitive endonucleases and subsequent PCR multiplication.

Taken together, we conclude that BNYVV RNA 4 is involved in the development of severe symptoms in *N.benthamiana*, and its severity of symptoms is not associated with levels of viral accumulation.

References

- Andika, I.B., Kondo, H., and Tamada, T. 2005. Evidence that RNA silencing-mediated resistance to *beet necrotic yellow vein virus* is less effective in roots than in leaves. *Mol. Plant-Microbe Interact.* **18**, 194-204.
- Lauber E., Guilley H., Tamada T., Richards K.E., and Jonard G. 1998. Vascular movement of beet necrotic yellow vein virus in *Beta macrocarpa* is probably dependent on an RNA 3 sequence domain rather than a gene product. *J. Gen. Virol.* **2**, 385-393.
- Richard, K.E., and Tamada, T. 1992. Mapping functions on the multipartite genome of beet necrotic yellow vein virus. *Annu. Rev. Phytopathol.* **30**, 291-313.
- Sambrook, J., Fritsch, E.F., and Maniatis, T. 1989. Molecular cloning. A Laboratory Manual. 2nd. Cold Spring Harbor Laboratory Press.
- Tamada, T. 1999. Benyvirus. Pages 154-160 in: Encyclopedia of Virology. 2nd ed. R.G. Webster and A. Granoff, eds. Academic Press, London.
- Tamada, T., and Abe, H. 1989. Evidence that beet necrotic yellow vein virus RNA 4 is essential for efficient transmission by the fungus *Polymyxa betae*. *J. Gen. Virol.* **70**, 3391-3398.
- Tamada, T., Shirako, Y., Abe, H., Saito, M., and Kiguchi, T. 1989. Production and pathogenicity of isolates of beet necrotic yellow vein virus with different number of RNA components. *J.Gen. Virol.* **70**, 3399-3409.

MONOCLONAL ANTIBODIES FOR DIFFERENTIATION BETWEEN *SOIL-BORNE CEREAL MOSAIC VIRUS* AND *SOIL-BORNE WHEAT MOSAIC VIRUS*

Frank Rabenstein, Heidrun Mühlheim, Ute Kastirr and Thomas Kühne

Federal Center for Breeding Research on Cultivated Plants, Institute of Resistance Research and Pathogen Diagnostics, Aschersleben, P.O. Box 1505, 06435 Aschersleben, Germany,

Summary

From rye and wheat varieties grown in different regions in Germany rod-shaped virus particles were isolated. By means of specific primer combinations isolate 'Heddesheim' (H) was verified as a German strain of *Soil-borne wheat mosaic virus* (SBWMV) whereas all the other isolates were assigned to *Soil-borne cereal mosaic virus* (SBCMV). On the other hand, by use of immunoassays with polyclonal antisera (PAS) to SBWMV and SBCMV originating from different laboratories it was neither possible to discriminate the isolates in ELISA and Western blots (WB) nor on the basis of their symptoms on *C. quinoa*. The ATCC type strain of SBWMV and the German isolates 'Eilte', 'Eickeloh' and H were propagated on rye variety 'Nikita' for virus purification and antiserum production. Only two of the eight PAS produced to furovirus isolates reacted in DAS-ELISA, WB and tissue print immunoassay (TPIA) mainly with the homologous virus. However, at high virus concentrations a specific discrimination between SBWMV and SBCMV with PAS was doubtful, particularly by their application in TPIA. Therefore, monoclonal antibodies (MABs) were produced. For discrimination of SBWMV isolates MAB 4G4 (IgG3, κ) was selected and used for the development of a sensitive MAB-based DAS-ELISA detection system. For specific recognition of all SBCMV isolates MAB 4G11 (IgG2a, κ) can be recommended for application in TAS-ELISA. The virus species-specific MABs showed in TPIA no background reactions and can be applied singly or in combination for virus detection in routine resistance tests.

Introduction

The two furoviruses *Soil-borne cereal mosaic virus* (SBCMV) and *Soil-borne wheat mosaic virus* (SBWMV, the type member of the genus), have been reported to occur in many winter cereal growing regions of the world (for reviews see [Kanyuka et al. 2003](#); [Chen, 2005](#)). In Germany, furoviruses were first isolated from rye ([Proeseler et al., 1982](#)) and wheat ([Huth and Lesemann, 1996](#)) and were considered as isolates SBWMV. A similar furovirus formerly described as *Soil-borne rye mosaic virus* (SBRMV) was characterized by [Koenig et al. \(1999\)](#). The virus has also been designated as European wheat mosaic virus (EWMV) ([Diao et al., 1999](#)). Molecular analyses have afterwards shown that a high degree of sequence similarities exist between the furoviruses isolated in France entitled EWMV ([Koenig and Huth, 2000](#)) and SBRMV isolated from cereals in Germany and Italy ([Yang et al. 2001](#); [Ratti et al. 2004](#)). Similar furoviruses have been also isolated in Denmark, Italy, Poland and the UK ([Kastirr et al., 2004](#)). Although these isolates were originally referred to as strains of SBWMV they share considerably less sequence identity with strains of SBWMV from the USA and Japan. Therefore the European strains of SBWMV have been classified as a separate species named SBCMV ([Torrance and Koenig, 2005](#)). On the other hand, [Koenig & Huth \(2003\)](#) have recently confirmed by sequencing the natural infection of wheat by a strain of SBWMV in a field near Heddesheim in Southern Germany. Therefore, the main objective of this study was to develop immunoassays that offer the possibility to discriminate both furoviruses in plant tissues by means of monoclonal antibodies. It should be also verified

how immunoassays can be used in studies to evaluate the resistance of wheat varieties to SBCMV.

Materials and Methods

Virus isolates were obtained from rye and wheat samples originating from different regions in Germany. Virus isolates were transmitted through infected soil to wheat, rye, and triticale and by mechanical inoculations to *Chenopodium quinoa*. By means of immunocapture RT-PCR with specific primer combinations (Cajza and Jezewska, 2003, Ratti et al. 2004) isolate 'Heddesheim' (H) was verified as a German strain of *Soil-borne wheat mosaic virus* (SBWMV) whereas all the other isolates were assigned to *Soil-borne cereal mosaic virus* (SBCMV). The ATCC type strain of SBWMV and the German SBCMV isolates 'Eilte', 'Eickeloh' and H were purified by differential ultracentrifugation from inoculated rye plants of variety 'Nikita' and used as antigen for polyclonal antiserum production in rabbits and for immunization of mice for production of monoclonal antibodies. A total of 8 polyclonal antisera (PAS) were raised in rabbits and further 4 PAS originating from different sources and prepared to viral antigens of purified furovirus preparations (SBCMV, DSMZ Braunschweig, and SBWMV, University of Nebraska, USA, and Japanese strain JT) were tested in various immunological detection systems using standard protocols (Hampton et al. 1990). MABs were obtained to the type strain of SBWMV and to SBCMV isolate 'Eickeloh' using standard cell fusion and cloning techniques. Positive hybridoma clones were selected and by using infected plant sap as antigen in TAS-ELISA.

Results and Discussion

Host range studies revealed that both viruses caused local lesions (LL) on *Chenopodium quinoa* Willd. and similar symptoms on wheat and rye plants (data not shown).

Fig. 1. Western blot analysis of CPs of SBWMV and SBCMV isolates probed with PAS 45 to SBWMV-ATTC type strain. Lanes: 1 healthy rye, 2 SBCMV-Eickeloh, M protein marker, 4 SBWMV type (rye), 5 SBWMV type (wheat), 6 SBWMV-Heddesheim (rye), 7 SBWMV-Heddesheim (wheat), 8 SBWMV-Heddesheim purified virus preparation, 9 healthy wheat, 10 buffer control

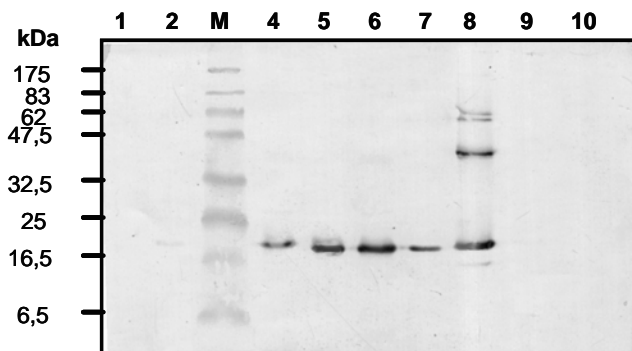

By means of the 12 polyclonal antisera (PAS) to SBWMV and SBCMV originating from different laboratories it was not possible to discriminate these isolates in DAS-ELISA or by Western blots (WB) (data not shown).

Only two out of 8 antisera (PAS-45 and PAS-69 which were produced to the type strain of SBWMV and to isolate H), showed no or only a weak cross-

reaction with another isolate (Fig. 1, lane 2). With all the other PAS especially when applied in tissue print immunoassay (TPIA), a specific discrimination between both furoviruses was not possible. The additional bands visible in lane 8 (purified virus preparation of SBWMV isolate H) could represent the readthrough protein. The 19-kDa capsid protein UGA termination codon on RNA2 can be partially suppressed to produce an 84-kDa readthrough protein (Shirako and Wilson, 1993). Evidence from other fungus-transmitted rod-shaped viruses revealed that the coat protein readthrough domain is incorporated into virions and located at one end of the particle.

From two fusion experiments arose four MABs. The reactivity of the selected antibodies to SBCMV and SBWMV in TAS-ELISA and in Western blotting experiments (WB) using infected plant sap is summarized in Table 1. In TAS-ELISA format no cross-reaction of MABs with the

Table 1. Reaction of selected monoclonal antibodies (MABs) to SBCMV und SBWMV in TAS-ELISA and Western blots (WB)

MAB	Antigen/ Origin	Isotype	TAS-ELISA		WB	
			SBWMV*	SBCMV**	SBWMV	SBCMV
MAB 4G4	SBWMV/ATCC	IgG3, κ	+++	-	+++	-
MAB 3B3	SBCMV- Eikeloh	IgM, λ	-	++	-	-
MAB 4G11	SBCMV- Eikeloh	IgG2a, κ	-	+++	-	-
MAB 4G7	SBCMV- Eikeloh	IgA, κ	-	+	-	-

* the two isolates ATCC type and Heddeshheim gave comparable results

** all tested SBCMV isolates from the Aschersleben collection reacted similar

heterologous furovirus was observed. Only MAB 4G4 (isotype IgG3, κ) reacted in both immunoassays whereas none of the MABs to SBCMV showed after treatment with SDS reactivity in Western blots suggesting that the recognized epitopes are all conformation sensitive. MAB 4G4 was again the only antibody which showed good activity after conjugation with alkaline phosphatase (AP). Therefore, a sensitive DAS-ELISA system based on MAB 4G4 as coating antibody and as AP-conjugate was developed for SBWMV detection in plant sap. For specific discrimination of all SBCMV isolates MAb 4G11 (IgG2a, κ) can be recommended for use in TAS-ELISA (Table 1). Collectively, the two selected virus species specific MABs allow in contrast to all tested PAS (data not shown) in tissue print immunoassay (TPIA, Fig. 2) an excellent discrimination between both furoviruses and can be applied in large-scale resistance trials.

MABs and PAS to Chinese wheat mosaic virus (CWMV) were produced by [Ye et al. \(2000\)](#). These antibodies and the Oklahoma isolate of SBWMV (SBWMV-OkI) were used to

Fig. 2. Comparison of TPIA and ELISA systems for detection of SBCMV in 21 samples: 1-7 positive for *Wheat spindle streak mosaic virus* in DAS-ELISA, 7-12 healthy plants, 13-15 positive for SBWMV in DAS-ELISA based on MAB 4G4, 16-21 positive for SBCMV in TAS-ELISA using MAB 4G11.

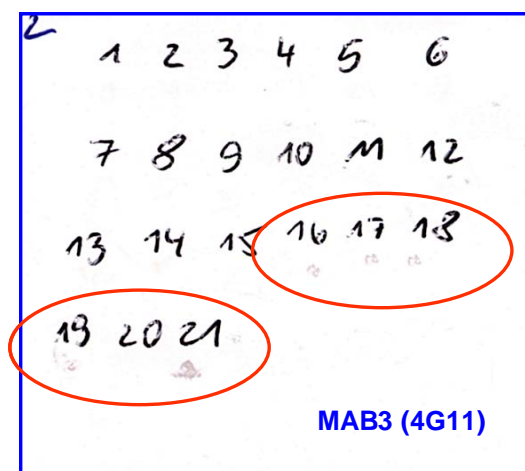

differentiate the wheat and oat furoviruses, CWMV, SBWMV, oat golden stripe virus (OGSV) and EWMV (SBCM). Computer analysis of the coat protein (CP) sequences suggested that the epitope shared between CWMV and OGSV was located at amino acids (aa) 35 to 40, whereas the dominant epitopes of SBWMV-OkI, which were shared with CWMV, EWMV and OGSV, were in the C terminal half of the CP. Both specific- and cross-reacting MABs were prepared against an isolate of SBWMV from Oklahoma by [Chen et al. \(1997\)](#). Peptide scanning analysis indicated that the epitope recognized by a specific MAB (SCR 134) is located near the N-terminus of the CP.

On the basis of sequence comparisons we suggest that the amino acids in the range of aa 19 to aa 23 in the CP N-terminus may display virus specific coat protein motifs. We conclude that motifs ATHAY and SIHPF could form specific epitopes for discrimination between SBWMV and SBCMV, respectively.

We thank Drs. Y. Shirako (University of Tokyo), R. French (University of Nebraska) and S. Winter (DSMZ Braunschweig) for supply with polyclonal antisera and Ms. E. Zimmermann and M. Wesemann for their excellent technical assistance.

References

- Cajza M., and Jezewska M. (2004). Use of RT-PCR for the detection of *Soil-borne cereal mosaic virus* (SBCMV) and *Soil-borne wheat mosaic virus* (SBWMV). *Phytopathologia Polonica* **29**, 81-85.
- Chen, J. P. (2005). Progress and prospects of studies on *Polymyxa graminis* and its transmitted cereal viruses in China. *Progress in Natural Science* **15**, 481-490.
- Chen, J. P., Torrance, L., Cowan, G. H., MacFarlane, S. A., Stubbs, G., and Wilson, T. M. A. (1997). Monoclonal antibodies detect a single amino acid difference between the coat proteins of soilborne wheat mosaic virus isolates: Implications for virus structure. *Phytopathology* **87**, 295-301.
- Diao, A. P., Chen, J. P., Gitton, F., Antoniw, J. F., Mullins, J., Hall, A. M., and Adams, M. J. (1999). Sequences of European wheat mosaic virus and oat golden stripe virus and genome analysis of the genus *Furovirus*. *Virology* **261**, 331-339.
- Hampton, R.; Ball, E.; and De Boer, S. (Eds.) 1990. *Serological Methods for Detection and Identification of Viral and Bacterial Plant Pathogens*. APS Press. St. Paul. MN., USA, 389 pp.
- Huth, W., and Lesemann, D.-E. (1996). Fungus-transmitted soil-borne viruses on rye in Germany. *J. Plant Dis. Protect.* **103**, 120-124.
- Kanyuka, K., Ward, E., and Adams, M. J. (2003). *Polymyxa graminis* and the cereal viruses it transmits: a research challenge. *Molecular Plant Pathology* **4**, 393-406.
- Kastirr, U., Rabenstein, F., and Kühne, T. (2004). Soil-borne cereal mosaic. *Soil-borne cereal mosaic furovirus*. In: Lapiere, H. & Signoret, P.-A. (Eds): *Viruses and Virus Diseases of Poaceae (Gramineae)*, INRA Editions, pp. 580-585.
- Koenig R., and Huth W. (2000). Soil-borne rye mosaic and European wheat mosaic virus: two names for a furovirus with variable genome properties which is widely distributed in several cereal crops in Europe. *Arch. Virology* **145**, 689-697.
- Koenig R., and Huth, W. (2003). Natural infection of wheat by the type strain of *Soil-borne wheat mosaic virus* in a field in southern Germany. *Eur. J. Plant Pathol.* **109**, 191-193.
- Koenig R., Pleij C.W.A., and Huth W. (1999). Molecular characterization of a new furovirus mainly infecting rye. *Arch. Virology* **144**, 2125-2140.
- Proeseler G., Stanarius A., and Eisbein K. (1982). Nachweis weiterer Viren am Getreide in der DDR. *Archiv f. Phytopathologie u. Pflanzenschutz* **18**, 397-403.
- Ratti, C., Budge, G., Ward, L., Clover, G.; Rubies-Autonell, C., and Henry, C. (2004). Detection and relative quantitation of *Soil-borne cereal mosaic virus* (SBCMV) and *Polymyxa graminis* in winter wheat using real-time PCR (TaqMan). *J. Virol. Meth.* **122**, 95-103.
- Shirako Y., and Wilson T. M. A. (1993). Complete nucleotide sequence and organization of the bipartite RNA genome of soil-borne wheat mosaic virus. *Virology* **195**, 16-32.
- Torrance L., and Koenig R. (2005). In: C.M. Fauquet, M.A. Mayo, J. Maniloff, U. Desselberger & L.A. Ball (Eds.) *Virus Taxonomy. Eighth Report of the ICTV*, Elsevier Academic Press, San Diego, USA, pp. 1027-1032.
- Yang J.P., Chen J. P., Chen J. O., Cheng Y., and Adams M. J. (2001). Sequence analysis of a soil-borne wheat mosaic virus isolate from Italy shows that it is the same virus as European wheat mosaic virus and Soil-borne rye mosaic virus. *Science in China Series C-Life Sciences* **44**, 216-224.
- Ye, R., Xu, L., Gao, Z. Z., Yang, J. P., Chen, J., Chen, J. P., Adams M. J., and Yu, S. Q. (2000). Use of monoclonal antibodies for the serological differentiation of wheat and oat furoviruses. *Journal of Phytopathology* **148**, 257-262.

TYPICAL RUSSIAN ISOLATE OF TOBACCO NECROSIS VIRUS

R.V. GNUTOVA & V.F. TOLKACH

Institute of Biology and Soil Science, Far East Branch of Russia Academy of Sciences
690022, Vladivostok-22, 159, Pr-t 100-letiya. E mail: ibss@ eastnet. febras.ru Fax: 7
(4232)310193

Introduction

In the south of the Russian Far East the narcissus plants with the symptoms of chlorotic streaks in narcissus leaves are found out. Symptoms are very rich and in time increase in sizes that can lead to plant death. The buds of diseased flowers are not exploded or small flowers are formed with necrotic streaks on the leaves. Virus vastly makes worse plant appearance and commercial quality as well. First, symptoms of disease caused by virus were described in Holland in 1931 during research of tulips "Augusta" from which the name "August disease" arose. In 1949 researchers from England and Holland showed that tulip disease is called Tobacco Necrosis Virus (TNV) (Bryun Ouborter, van Slogteren, 1949; Kassanis, 1949). Later TNV was found out not only on tulip leaves but on petunia, phlox, narcissus and others.

Test-plants to react the virus inoculation

<i>Species and plant sorts</i>	<i>Time after inoculation, days</i>	<i>Symptoms</i>
Antirrhium majus	6-7	L:NSp
Amaranthus caudatus	6-7	-“-
Callistephus chinensis	4-5	-“-
Chenopodium amaranticolor	2-3	-“-
Ch. quinoa	5	-“-
Ch. murale	2-3	-“-
Cucumis sativus ‘Far–East 6’	4-6	-“-
Datura stramonium	3-5	-“-
Gomphrena globosa	5	-“-
Lathyrus sativum	5	-“-
Lycopersicon chinense	5	-“-
L. esculentum ‘Daka’	5	-“-
L. esculentum ‘Present’	5	-“-
Nicotiana tabacum ‘Samsun’	3-6	-“-
N. tab. ‘Xanthi’	3-6	-“-
N. rustica	3-6	L:CISp
Nicandra physaloides	4-5	L:NSp
Petunia hybrida ‘Primadonna’	3-5	-“-
Paseolus vulgaris ‘Beka’	3	-“-
P. vulgaris ‘Saxa’	2	-“-
Pusum sativum ‘Stepnoj’	3-6	-“-
P. sativum ‘Matator’	3-6	-“-
Spinacia oleracea	6-7	-“-
Tetragonia expansa	6	-“-
Vicia faba ‘Black eye’	6	-“-
Zinnia elegans	6	-“-

Material and methods

For identification of the Russian TNV isolate, twenty six plant species from several families (Aizoaceae, Asteraceae, Amaranthaceae, Chenopodiaceae, Cucumbitaceae, Fabaceae, Scrophulariaceae, Solanaceae) were used as test-plants (Table).

No infection: **Medicago sativa, Solanum nigrum, Papaver corniferum, Trifolium hybridum**

'Primorsky', Callistephus chinensis, Atropa belladonna, Ocimum basilicum, Melilotus officinalis, M. indica, M. album, Lychnis chalconica

Results and discussion

Inoculated plants were infected by the disease agent. Test-plants react to the virus inoculation by local reaction: *Nicotiana rustica* L. (chlorotic ringspots develop on 3-6 days), *Chenopodium quinoa* Willd., *Cucumis sativus* L. (necrotic ringspot on 3rd day), *Phaseolus vulgaris* L., *N. tabacum* L. cvs. Samsun, Xanthi (necrotic spots appear on inoculated leaves over 3-6 days). The range of TNV host-plants is quite large, about 88 species related to 37 families (Kassanis, 1970). Most of them reactions to infection by local necrosis (Fig. 1,2).



Fig. 1. Cucumis sativus: L:NSp

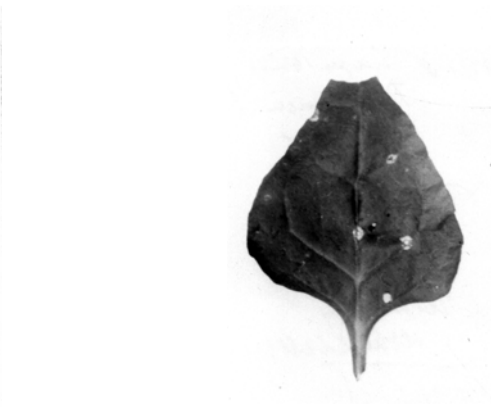

Fig. 2. Tetragonia expansa : L:NSp

Physical characteristics of Russian TNV isolate were determined. Sap of cucumber leaves inoculated by the virus preserves infectivity even at heating to (TIP) - 85C. At room temperature virus retains in sap during (LIV) 30 days. The virions of the spherical form are 28 nm in diameter (Fig. 3).

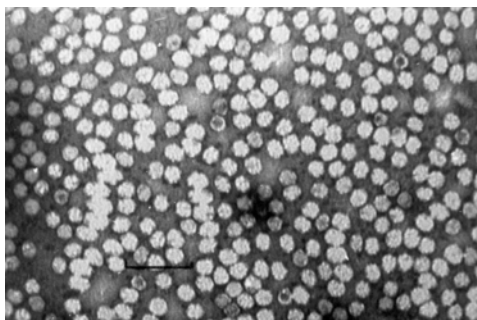

Fig. 3. Electronic microphotoes of virions TNV in preparation

Virus availability in infected plants was confirmed by specific antiserum. TNV survived in infected narcissus bulbs. There was no information about TNV carriers in environment for a

long time. After establishing (Teakle, 1962) that TNV in lettuce roots is transmitted by zoospore *Olpidium brassicae* (Wor.) Dang, the author began study of oriental plants. He tried to find out fungus in narcissus roots but attempt was unsuccessful. This suggests that fungus *O.brassicae* is the virus carrier even to such plants where it doesn't paratize in roots.

It was determined that self-sown plant of preceding cereals can be the host both *O.brassicae* and TNV. Fungus was isolated from mustard roots and was able to transmit TNV. It was shown that mustard, carrot, and four species of crop plants can be TNV hosts. None of these plants were systematically infected. Symptoms were found out only in carrot roots. Dependence between time of infection appearance caused by TNV, for example on tulips, and amount of *O.brassicae* on weed roots was determined. Optimal conditions for fungus spreading, for example on tulips are moist autumn and early winter without strong frost (Lange, 1976). Disease caused by TNV are mostly to be found in moist acid sandy soils. If tulips are planted in the back-end (late October - early November) they are infected less then in September (Putnaergle, 1976). The virus is easily transmitted by fungus *Olpidium brassicae* and mechanically. On base of the symptoms, range of the host-plants, morphology of the virions, and transmission of the virus by fungus *Olpidium brassicae* and special reaction to antiserum we consider that the virus isolated from the narcissus refer to TOBACCO NECROSIS VIRUS (TNV) species of Necrovirus genus.

In the result of literary data and our experiments the identified isolate refers to ordinary strain of TNV. The purified virus preparation has been obtained either from the fresh cut material or long conserved, frozen or dried (plants with the necrosis: *Ch. gunoa*, *Cucumis sativus*, *Ph. vulgaris*, *N. tab.* 'Samsun' and 'Xanthi'). Virus concentration and morphology of the particles of the obtained preparations do not differ essentially. That proved high TNV (from narcissus) stability. The virus output was 50 mg/kg (*Phaseolus vulgaris* L.). TNV is good immunogen. The infections in 200 - 500mkg, made for the rabbits under skin and intra skin methods in the localities of lymphonodus, have provided for obtaining antiserum with high content specific antibodies (Fig. 4).

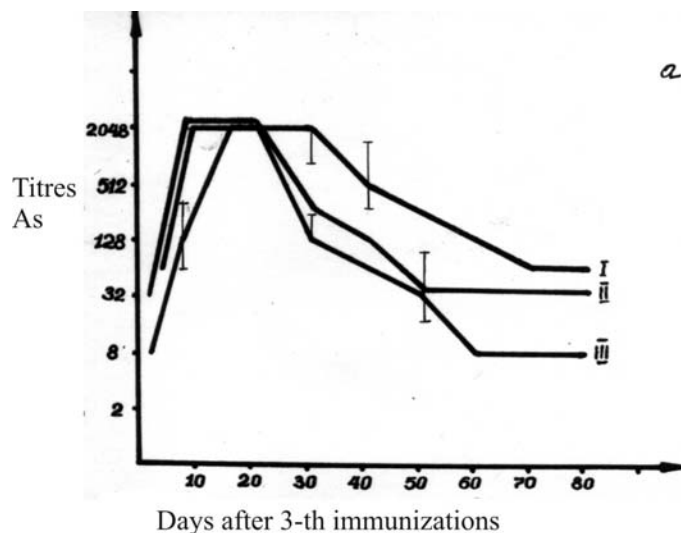

Fig. 4. Titre antiserum to Russian isolate TNV.

The comparative investigations of the antigen relationships in the RDD Russian and Latvian isolates of TNV showed that they are not identical. The Latvian isolate, obtained from a cucumber, was the most close on its antigen properties to Russian isolate but not to isolates causing diseases by fungus *Olpidium brassicae* (Fig. 5).

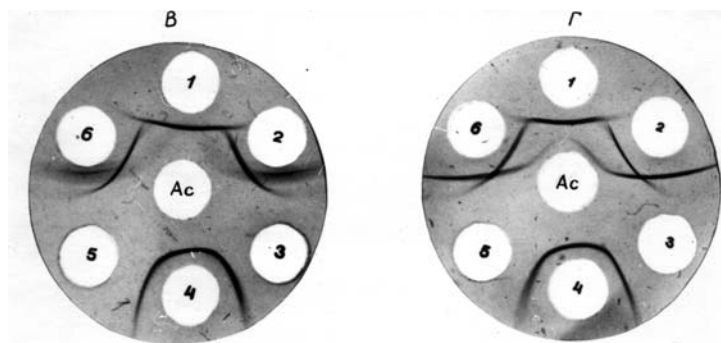

Fig. 5. Antigen relations between Russian and Latvian isolates

1,4 - sap of leaves *Ph. vulgaris* inoculated of Russian isolate TNV
2,6 - sap of leaves *Ch. quinoa* inoculated of Latvian isolate TNV
3 - control (sap of leaves *Ph. vulgaris*)
5 - control (sap of leaves control *Ch. quinoa*)
As to Russian isolate TNV

References:

- Bryun Ouborter M.P. de, van Slogteren E// Tijdschr. Plantenziekt., 1949, Vol. 55, N5. P.262-271
 Kassanis B. // Ann. Fppl. Biol..1949. Vol. 36. N1. P. 14-17.
 Kassanis B. // C.M.I/A.A.B.Description of Plant Viruses. 1970. N14. P. 1-4.
 Lange L.// Tidsskr. Planteavl. 1976.Vol.80, N2. P.153-169
 Teakle D.S.//Virology. 1962.Vol.18. P.224-231.

MOLECULAR COMPARISON OF SOIL-BORNE CEREAL MOSAIC VIRUS ISOLATES ORIGINATING FROM GERMANY AND FRANCE

R. Goetz¹ and W. Huth²

¹FR. Strube Saatzucht KG, c/o Biologische Bundesanstalt für Land- und Forstwirtschaft, Institut für Pflanzenvirologie, Mikrobiologie und biologische Sicherheit, Messeweg 11-12, D-38104 Braunschweig

²Biologische Bundesanstalt für Land- und Forstwirtschaft, Institut für Pflanzenvirologie, Mikrobiologie und biologische Sicherheit, Messeweg 11-12, D-38104 Braunschweig

Summary

Soil-borne cereal mosaic virus (SBCMV) infects wheat, rye and triticale commonly in European countries, such as France, Italy and Germany but has also been reported from Denmark, Poland and the UK. Due to the fact that SBCMV is transmitted by *Polymyxa graminis*, growing resistant varieties represents the only economical means of control. Since SBCMV resistance in wheat seems to be a translocation resistance, the movement protein (MP) sequences of five SBCMV isolates from Germany and France were determined and compared with published MP sequences of other SBCMV isolates. Although the MP amino acid sequences of the SBCMV isolates had an identity of > 93%, they differed to such an extent that three distinct groups of SBCMV isolates showing a geographically associated variation were revealed. The German isolates were differentiated and formed two distinct clades. In contrast, the five isolates from France, Italy and UK belonged to another separate group of SBCMV isolates. In conclusion, the assignment of an SBCMV isolate to one of the three groups seems to depend on its geographic origin.

Introduction

Soil-borne cereal mosaic virus (SBCMV) is a member of the genus *Furovirus*. Members of this genus have rigid rod-shaped virions and a bipartite positive-sense RNA genome. They infect gramineous plants and are transmitted by *Polymyxa graminis*. SBCMV occurs commonly in European countries such as France, Italy and Germany but also in Denmark, Poland and the UK. The virus causes a serious disease of wheat, rye and triticale, and persists in resting spores of *P. graminis* in the soil for over 10 years. Due to the persistent nature of the virus in soils, growing resistant varieties represents the only economical means of SBCMV control.

RNA-1 of SBCMV contains three open reading frames (ORF), one (ORF3) of which encodes the putative movement protein (MP). Since resistance of wheat against SBCMV seems to be a translocation resistance (Huth *et al.*, 2005), the molecular determinants of the SBCMV MP might be significant factors for the efficacy of host plant resistance. Therefore, the MP nucleotide and amino acid sequences of five SBCMV isolates from Germany and France were determined and compared with published sequences of several other SBCMV isolates.

Materials and Methods

Leaf and root material were collected from winter wheat plants growing in heavily infested fields at different locations in Germany and France (see Table 1). A total of five SBCMV isolates from Germany and France were selected and studied.

Table 1: Origin of SBCMV isolates studied and used for sequence alignment.

SBCMV isolate (location)	Country	References
SBCMV-L (Langlingen)	Germany	present study
SBCMV-W (Walternienburg)	Germany	present study
SBCMV-E (Eickeloh)	Germany	present study
SBCMV-Gu (Guilly)	France	present study
SBCMV-H (Hariri)	France	present study
SBCMV-C (Celle)	Germany	AF146279
SBCMV-O (Osnabrück)	Germany	AF146280
SBCMV-G (Glendorf)	Germany	AF146278
SBCMV-UK (Wiltshire)	UK	AJ298068
SBCMV-France (France)	France	NC_002351
SBCMV-Italy (Ozzano)	Italy	AJ252151

Total nucleic acid (TNA) was extracted from leaf material collected from field-grown plants. TNA was isolated according to a modified extraction method described by Menzel *et al.* (2002).

TNA was used as template for RT-PCR. The RNA was reverse-transcribed with AMV reverse transcriptase (Finnzymes) and cDNA fragments were amplified with Taq polymerase (BioLabs) in a one-step RT-PCR procedure. RT-PCR was done using a SBCMV-specific antisense and sense oligonucleotide amplifying the MP gene of the virus. The RT-PCR reaction was carried out according to standard conditions. The generated DNA fragments were ligated into pGEM-T using the pGEM-T-vector system (Promega) and subsequently cloned into *E. coli* DH5 α (Invitrogen). Selected clones were sequenced by a commercial company (MWG Biotech).

The sequence data of SBCMV were analysed with DNAMAN. Five isolates of SBCMV from Germany and France were analysed and compared to analogous SBCMV sequences available from Genbank databases (see Table 1). For pairwise comparisons BLAST2 was used, and multiple alignments of the movement protein sequences were done using the default parameters of CLUSTAL X (Thompson *et al.*, 1997). The phylogenetic tree was generated using TreeView (Page, 1996).

Results and Discussion

For comparison of SBCMV isolates originating from different European countries especially Germany (Table 1), their MP sequences were used.

Comparison of MP sequences

The MP amino acid sequences of different isolates of SBCMV shared a high degree of identity (more than 93%). Nevertheless, they showed different degrees of identity. The different isolates of SBCMV were separated into three groups (Fig. 1). One group includes three isolates from France and one isolate each from the UK and Italy. The isolates of the other two groups all originated from Germany but represent two different areas. In conclusion, the separation into one of the three groups depends on the geographic origin of the isolates.

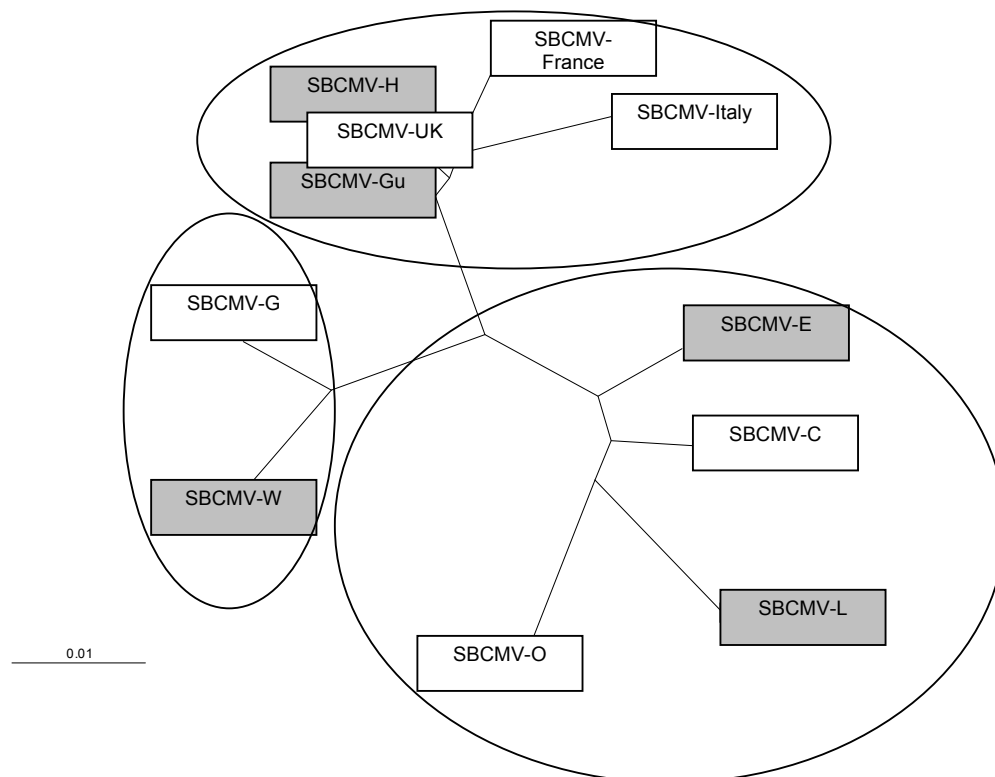

Fig. 1. Phylogenetic relationships among 11 isolates of SBCMV based on multiple alignment of the amino acid sequence of their movement protein. For abbreviation see Table 1; ellipses: groups of most closely related isolates; clear box: sequence data from Genbank; shaded box: own results (sequence data).

MP amino acids exchanges

The different isolates showed not only different degrees of MP amino acid sequence identity but also a few specific amino acid exchanges (Fig. 2). Whereas some amino acid exchanges occurred in only one isolate, others appeared to be characteristic for each of the three groups of SBCMV isolates (Fig. 1).

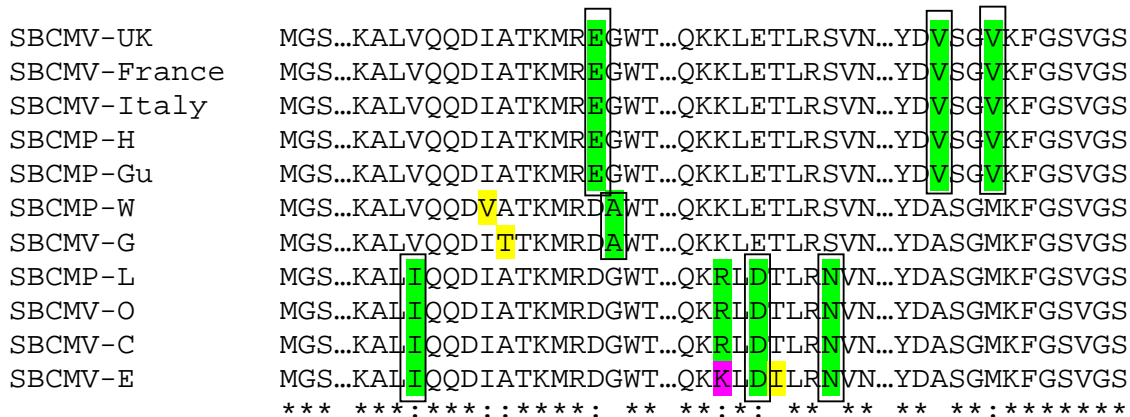

Fig.3: Alignment of selected regions of the MP amino acid sequences of different SBCMV isolates. Coloured box: amino acid exchange, yellow box: single aa exchange; green box: aa exchanges consistent with the grouping of isolates shown in Fig. 1.

In spite of the high degree of identity between the diverse isolates of SBCMV, differences occur in MP amino acid sequences. The isolates not only were assigned to different groups but also showed specific amino acid exchanges. This raises questions about possible implications of the observed differences for the virus-host interactions of the SBCMV isolates.

Acknowledgements

We thank Kathrina Rohst for excellent technical assistance.

References

- Huth, W., Lesemann, D.-E., and Goetz, R. (2005). Translocation resistance – most effective type of furovirus resistance in wheat. Proc., 6th IWGPVFV, Sep. 5-7, Bologna.
- Menzel, W., Jelkmann, W., and Maiss, E. (2002). Detection of four apple viruses by multiplex RT-PCR assays with coamplification of plant mRNA as internal control. J. Virol. Meth. **99**, 81-92.
- Page, R.D.M. (1996). TREEVIEW: An application to display phylogenetic trees on personal computers. Comput. Appl. Biosci. **12**, 357–358.
- Thompson, J.D., Gibson, T.J., Plewniak, F., Jeanmougin, F., and Higgins, D.G. (1997). The ClustalX windows interface: flexible strategies for multiple sequence alignment aided by quality analysis tools. Nucleic Acids Res. **24**, 4876–4882.

THE REASSORTMENT OF GENOMIC RNAs OF *WHEAT YELLOW MOSAIC VIRUS* (WYMV) PATHOTYPE I AND II IN A RESISTANT AND A SUSCEPTIBLE CULTIVAR.

Yasuo Ohto (1) and Jun-ichi Sakai (1)

(1) Laboratory of Disease Control, NARC-Tohoku, Akahira 4, Morioka, Iwate, 020-0198 Japan
ohtoe@affrc.go.jp

Summary

Japanese isolates of WYMV are divided into two pathotypes (I and II). Type I prevails broadly in the mid to western part of Japan, and type II is dominant only in the northern part of Japan. Although the distribution of pathotypes probably relates to the resistance of cultivars grown in each area, details of the relationships between pathotypes and resistance of wheat cultivars are still unclear. To investigate the interaction between different pathotypes in resistant and susceptible cultivars, WYMV types I and II were co-inoculated to cultivars 'Fukuhokomugi' (resistant to type II) and 'Nanbukomugi' (susceptible to both types), and the propagation of each type was monitored by using RT-PCR. Primers for specific detection of RNA1 and 2 of each type of WYMV were prepared based on differences of the sequences in the VPg region in RNA1 and 3'-UTR in RNA2 between the two types. In infected 'Fukuhokomugi' plants, only RNA1 of type I was detected, while RNA2 of one or both of the pathotypes were detected. On the other hand, RNA1 and RNA2 of both of the pathotypes were detected in infected 'Nanbukomugi' plants. These results suggest that factors coded on RNA1 determine the pathogenicity to 'Fukuhokomugi'. However, in infected 'Nanbukomugi' plants, RNA1 from either type I or II was detected by itself in most cases, while RNA2 from both pathotypes was frequently detected together. These results imply that there is some competitive interaction between RNA1s in 'Nanbukomugi'.

Introduction

Wheat yellow mosaic occurs in Japanese wheat production areas. This disease causes serious damage as a result of yield reduction. *Wheat yellow mosaic virus* (WYMV), which belongs to family *Bymovirus*, is the causal agent of the disease, and is transmitted by *Polymyxa graminis* (which also transmits *Barley mild mosaic virus*). The virus has flexuous rod-shaped particles with two modal lengths, 500-600 and 250-300nm, containing two species of ssRNA of about 7.6Kb (RNA1) and 3.7 Kb (RNA2) (Namba *et al.* 1998). The use of resistant cultivars is a principal countermeasure to the disease.

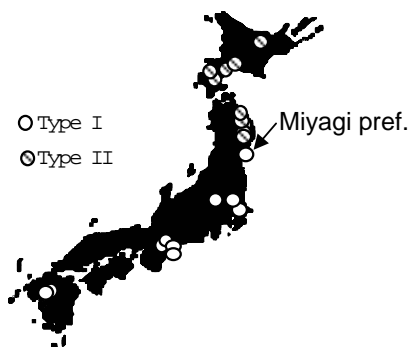

Fig. 1 Distribution of *Wheat yellow mosaic virus* pathotypes I and II.

Two pathotypes, type I and II, are recognized on the basis of pathogenicity to differential wheat cultivars. Type I can infect cvs. 'Fukuhokomugi', 'Norin 61' and 'Nanbukomugi', but cannot infect cv. 'Hokkai 240' (Ohto *et al.* 2003). Type II can infect cv. 'Nanbukomugi', but cannot infect the other cultivars. Only type I was isolated from the south of Miyagi prefecture (Fig. 1). It is probably because the cvs. 'Norin 61' or 'Fukuhokomugi' have been cropped in this area for a long time. As a result, type I became the dominant type in this area. However, only type II was isolated from the north of Miyagi prefecture although

susceptible cvs. to both pathotypes have been cropped in this area. One possible mechanism is that type I has some handicaps in competing with type II in cvs. that are cropped in the north of Japan. To test this hypothesis, we have previously reported that the propagation of isolate WYMV-T (type I) is affected more by a change of temperature than WYMV-M (type II) (Ohto and Ishiguro, 1999). However, competition between two pathotypes of WYMV in a susceptible cultivar is still unknown. It is also unknown what factor coded in genomic RNAs relate to the difference of pathogenicity between the two pathotypes of WYMV. In two pathotypes of *Barley mild mosaic virus* from Japan, the involvement of RNA1 to the pathogenicity and the presence of competitive interaction between genomes were suggested in experiments using reassortants of genomic RNAs (Kashiwazaki *et al.* 1996).

In this study, we co-inoculated two pathotypes of WYMV and analyzed the reassortment of the genomic RNAs of each pathotype in infected plants in order to examine relationships and competitive dynamics between the RNA components of two WYMV pathotypes.

Materials and Methods

WYMV isolates used Two WYMV isolates were used in this study. The isolate WYMV-T is a representative of type I that was isolated in Ibaraki prefecture from cv. 'Norin 61'. The complete nucleotide sequence of the isolate was determined and reported as D86634 in DDBJ. Another isolate, WYMV-M, representative of type II, was isolated from cv. 'Nanbukomugi' in Morioka, Iwate prefecture. WYMV-T and -M were maintained in wheat cv. 'Fukuhokomugi' and 'Nanbukomugi', respectively.

Wheat cultivars used The cv. 'Fukuhokomugi' was used as a cultivar which showed susceptibility to WYMV-T (type I) but resistance to WYMV-M (type II). It was confirmed that WYMV-M cannot propagate in this cultivar in inoculation experiments. The cv. 'Nanbukomugi' was used as a susceptible cultivar to both pathotypes of WYMV. This has been a major cultivar for over 30 years in Iwate prefecture where type II of WYMV is dominant.

Oligonucleotide primers for RT-PCR Oligonucleotide primers to detect RNA1 and RNA2 of each isolate were designed separately based on the differences of sequences in the VPg region of RNA1 and in 3'-UTR of RNA2. In order to determine nucleotide sequences of the VPg region of WYMV-T and WYMV-M, a forward primer VPg-1P (5'-TGAAGATGACTCCAGCGATG-3') and a reverse primer VPg-1M (5'-GACCTGGGATAGGAGAAATTC-3') were designed to amplify a part of RNA1 that includes whole VPg region based on the complete nucleotide sequence reported for WYMV (Namba *et al.* 1998). Then the RT-PCR products covering the VPg region were cloned and nucleotide sequence determined. A base permutation between two isolates found in the 4117th base in RNA1 (DDBJ Sequence Database accession no. D86634) was used as the 3' end of forward primers VPg-2P (5'-CAACTCACAACCCTAAYACTC-3') and VPg-3P (5'-CAACYCACGACCCYAACAARA-3'). In combination with a reverse primer VPg-1M, VPg-2P and VPg-3P were used for the amplification of the last half of VPg region of WYMV-T and -M, respectively. A forward primer ut-1P (5'-CTTAAGAGGTGGAGCACGGA-3') and a reverse primer ut-1M (5'-GACGATCGACAGGTGCATTG-3') were used for the amplification of 3'-UTR of RNA2. The nucleotide sequences of 3'-UTR of RNA2 of WYMV-T and -M were determined directly from RT-PCR products of each isolates. Based on the differences in nucleotide sequences, 2-TP (5'-GCATCACCTAACCACGAT-3') and 2-MP2 (5'-TGTTACGAGTTGTATACCTG-3') were designed for the amplification of RNA2 of WYMV-T and WYMV-M, respectively, in combination with ut-1M. Positions of all primers were shown in **Fig. 2**.

Co-inoculation of WYMV-T and WYMV-M Wheat leaves infected by each isolate were ground with phosphate buffer (pH 7.0) to prepare sap for mechanical inoculation. In co-inoculation experiments, equal volumes of sap were mixed and inoculated onto three-leaf

stage wheat seedlings of cv. 'Fukuhokomugi' and cv. 'Nanbukomugi'. Inoculated wheat plants were kept in a growth cabinet with 12hr day length ($190 \mu \text{ mol. photon/s/m}^2$) at 5.

Detection of RNA components by using RT-PCR Total RNA was extracted from approx. 100mg of the newly developed 4th leaf of inoculated wheat plants using TRIzol reagent (Invitrogen) according to the instruction manual, and dissolved in 100 μ l of sterile distilled water. One microliter of the total RNA solution was used for the 25 μ l RT-PCR reaction using a OneStep RT-PCR Kit (QIAGEN). After 30 minutes reverse transcription at 50 followed by 15 minutes incubation at 95, amplification was conducted in a 30cycle program of 1minute at 94, 30sec at 55 and 1minute at 72. An aliquot (5 μ l) of the PCR products was electrophoresed on agarose gels. For the PCR products of VPg region, 3% gels of NuSieve 3:1 agarose (BioWhittaker Molecular Applications) were used. For the PCR products of 3'-UTR, 1% gels of Agarose S (Wako Inc.) was used.

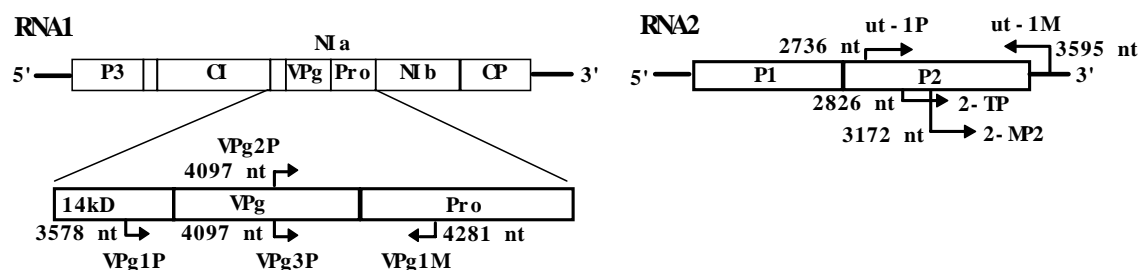

Fig. 2 Positions of RT-PCR primers used for the determination of nucleotide sequences and the specific detection of *Wheat yellow mosaic virus* genome RNA1 and RNA2 of two isolates, WYMV-T and WYMV-M.

RT-PCR products, amplified using VPg1P (forward) and VPg1M (reverse) were used for the determination of nucleotide sequences of VPg regions in RNA1 of isolates.

VPg2P and VPg3P are specific forward primers for RNA1 of WYMV-T and WYMV-M, respectively.

RT-PCR products, amplified using ut-1P (forward) and ut-1M (reverse) were used for the determination of nucleotide sequences of 3'-UTR in RNA2 of isolates.

2-TP and 2-MP2 are specific forward primers for RNA2 of WYMV-T and WYMV-M, respectively.

Results and Discussions

In most cases, reassortants detected in our study consisted of both RNA1 and RNA2. Only from one plant from each cv. 'Fukuhokomugi' and 'Nanbukomugi', T1 was detected by itself without RNA2 (**Table 1**). These results imply that the propagation and movement of RNA1 progress earlier than those of RNA2 in the process of symptom development, or RNA1 can propagate by itself although both RNA1 and RNA2 are essential for the development of symptoms.

From cv. 'Fukuhokomugi' (resistant to WYMV type II), the RNA1 of WYMV-M (M1) was not detected (**Table 1**). On the other hand, from cv. 'Fukuhokomugi', RNA2 of WYMV-M (M2) was detected together with the RNA2 of WYMV-T (T2) or by itself in combination with RNA1 of WYMV-T (T1). This result showed that WYMV could infect and induce disease to cv. Fukuhokomugi in combination with T1 with any type of RNA2. This result also suggests that M1 could not propagate in cv. 'Fukuhokomugi'. These results suggest that some factors coded on RNA1 determine the pathotypes. It is also suggests that some factors coded on RNA2 probably do not relate to the determination of the pathotype I and II.

Both types of RNA1 and 2 were detected from cv. 'Nanbukomugi' (which is susceptible to both WYMV type I and II) (**Table 1**). However, the RNA combination which was the same as the wild type of WYMV-M was dominant in cv. 'Nanbukomugi', and the detection frequency of RNAs of WYMV-T was lower than that of RNAs of WYMV-M. Comparing T1 with T2, the frequency of T1 was lower than that of T2. The reassortant that consists of both types of RNA1 was detected only once. There was no reassortant that has T1 as the only RNA1 in cv. 'Nanbukomugi'. These results suggest that in cv. 'Nanbukomugi' there are some competitive reactions between each genome RNAs of co-inoculated isolates, especially between RNA1s, and T1 probably has some handicaps to M1 in the competition. These competitive interactions

Table 1. The RNA combinations in cultivars 'Fukuhokomugi' and 'Nanbukomugi' after inoculation with a mixture of two WYMV isolates, WYMV-T and WYMV-M.

Genomic RNAs combination (RNA1/RNA2) ^{a)}	Number of reassortants with each RNAs combination	
	(Fukuhokomugi)	(Nanbukomugi)
T1	1	1
T1/T2	0	0
T1/M2	6	0
T1/T2M2	13	1
T2	0	0
M1	0	0
M1/M2	0	21
M1/T2	0	1
M1/T2M2	0	8
M2	0	0
T1M1/T2M2	0	1
T1M1/T2	0	0
T1M1/M2	0	0
inoculation efficiency	20/121	32/71

a) T1:RNA1 of WYMV-T, T2:RNA2 of WYMV-T, M1: RNA1 of WYMV-M, M2:RNA2 of WYMV-M

may result in the dominance of type II in the area where cv. 'Nanbukomugi' has been cropped.

References

- Kashiwazaki S. and Hibino H. (1996) Genomic reassortment of barley mild mosaic virus: evidence for the involvement of RNA1 in pathogenicity. *Journal of General Virology* 77: 581-585.
- Namba S., Kashiwazaki S., Lu X., Tamura M. and Tsuchizaki T. (1998) Complete nucleotide sequence of wheat yellow mosaic bymovirus genomic RNAs. *Arch. Virol.* 143:631-643.
- Ohto Y. and Ishiguro K. (1999) The effects of temperature on the reaction of two wheat cultivars to different wheat yellow mosaic bymovirus (WYMV) strains. In: *Proceedings of the Fourth Symposium of IWGPVFFV.* pp.119-122.
- Ohto Y., K. Hatta and Ishiguro K. (2003) Establishment of the differential wheat cultivars set to discriminate pathogenicities of the Japanese *Wheat yellow mosaic virus* (WYMV) isolates. In *Abstract of offered papers of 8th International Congress of Plant Pathology.* pp.305.

THE RNA SILENCING-MEDIATED RESISTANCE TO *BEET NECROTIC YELLOW VEIN VIRUS*: DIFFERENCES OF THE SILENCING ACTIVITY IN LEAVES AND ROOTS

Ida Bagus Andika, Hideki Kondo, and Tetsuo Tamada

Research Institute for Bioresources, Okayama University, Kurashiki, Okayama 710-0046, Japan

Summary

Transgenic *Nicotiana benthamiana* plants carrying the coat protein readthrough domain open reading frame (54 kDa) of *Beet necrotic yellow vein virus* (BNYVV) displayed resistant and recovery phenotypes which are either mediated by RNA silencing. In resistant plants, virus could replicate at low levels in roots when inoculated by the vector fungus *Polymyxa betae* whereas the leaves of the same plants were immune to foliar rub-inoculation. In recovery plants, virus still accumulated at high levels in roots although virus accumulation was greatly reduced in upper recovered leaves. Transgene transcripts were detected to accumulate at higher levels in roots than in leaves of resistant plants and this was inversely related with the accumulation of transgene-derived small interfering RNAs (siRNAs). In addition, transgene DNA methylation levels at non-symmetrical CpNpNp context were lower in roots than in leaves of resistant plants. Similarly, in nontransgenic plant inoculated with BNYVV, virus accumulated at higher levels in roots than in leaves and also was inversely related with accumulation of virus-derived siRNAs. Taken together, these results indicate that RNA silencing activity is less active in roots than in leaves.

Introduction

RNA silencing is a sequence-specific RNA degradation pathways highly conserved in a broad range of eukaryotes. It is believed that one of its biological function is to operate against RNA/DNA viruses (Vance and Vaucharet, 2001). Generation of transgenic plant with silencing for the sequence derived from the virus genome has been proven to be an effective strategy to control various diseases caused by plant virus infection (Goldbach *et al.*, 2003).

Beet necrotic yellow vein virus (BNYVV; genus *Benyvirus*) is transmitted by the soil-inhabiting plasmodiophoromycete fungus *Polymyxa betae* and causes the economically important rhizomania disease of sugar beet. BNYVV has rigid-rod-shaped virions and a multipartite plus-strand RNA genome, which consists generally of four, or in some isolates, five distinct RNA species, referred to as RNA1 to RNA5. RNA1 and RNA2 encode “house-keeping” genes involved in viral RNA replication, assembly and cell-to-cell movement. RNA3, RNA4 and RNA5 are associated with vector-mediated infection and disease development in sugar beet roots (Tamada, 1999).

Transgenic *Nicotiana benthamiana* plants carrying the 54-kDa readthrough domain open reading frame (54 kDa RTD-ORF) of BNYVV display high resistance and recovery phenotypes which are either mediated by RNA silencing (Andika *et al.*, 2005). So far, RNA silencing-mediated virus resistance in transgenic plants has been shown effective in aerial part of the plant; however, there is little information as to whether RNA silencing-mediated resistance is also effective in roots. In this study, we assayed the virus accumulation in roots of resistant and recovered transgenic plants. We compared the levels of RNA degradation, siRNA accumulation and transgene DNA methylation in roots and leaves. The results show that RNA silencing-mediated resistance to BNYVV is less effective in roots than in leaves and this phenomenon is possibly due to the lower RNA silencing activity in roots.

Materials and methods

Plant materials and virus inoculation

Transgenic *N. benthamiana* plants carrying the 35S promoter:54-kDa RTD-ORF transgene were previously described (Andika *et al.*, 2005). For foliar rub-inoculation, BNYVV-O11-infected *N. benthamiana* leaves were used as described previously (Andika *et al.*, 2005). Fungus inoculation was carried out as described by Tamada and Kusume (1991).

Virus detection by ELISA, tissue imprinting and RT-PCR

ELISA of infected plants was conducted as described previously (Tamada and Abe, 1989). Tissue imprinting assay of infected plant was conducted as described previously (Andika *et al.*, 2005). RT-PCR was conducted as described previously (Andika *et al.*, 2005). For amplification of viral RNA, forward primer TGB3-N (5'-CAGAACATATTTTCATATGGTGCTTG-3') and reverse primer TGB3-B (5'-CCAT-CCCCATACGGATCCTACCAC-3') that specific for 15-kDa were used for amplification. For amplification of 54-kDa RTD-ORF transcripts, reverse primer specific for nos termination (5'-AAGATTGAATCCTGTTGCCG-3') and forward primer BN1350f (5'-ACTGTCTTGATCGAGAGGCG-3') were used. For amplification of alpha tubulin gene forward primer Tub2(f) (5'-GGTGGCTGATAGTTAATACC-3') and reverse primer Tub(rev) (5'-GATAACTGTACTGGTCTTCA-3') were used.

RNA and DNA blot analysis

Genomic DNA was isolated from root or leaf tissue as described by Murray and Thompson (1980). Total RNA was extracted from root or leaf tissue by the acid guanidinium thiocyanate-phenol-chloroform method (Chomczynski and Sacchi 1987). DNA/RNA gel electrophoresis and blot analysis were performed as described previously (Andika *et al.*, 2005). Extraction of low molecular weight RNAs and gel blot analysis of siRNAs were performed as described previously (Andika *et al.*, 2005).

Bisulphite sequence analysis

Bisulphite treatment was performed in the presence of urea essentially as described (Paulin *et al.*, 1998). The following primers were used to amplify the top strand of the 54-kDa RTD-ORF-nopaline synthase (Nos) terminator target: the forward primer RT-f (5'-GGGGTTAATAATAATATTAG-3') and the reverse primer Nos-r (5'-AAACCCATCTCATAAATAAC-3').

Results and discussion

Transformation of *N. benthamiana* with the 54-kDa RTD-ORF of BNYVV resulted in twenty transgenic lines in which six (30%), nine (45%) and five (25%) lines showing resistant, recovery and susceptible phenotype, respectively. Transgenic line RT24-2 has been characterized as a silencing line. This line accumulates low levels of transgene transcripts and a detectable level of siRNAs (Andika *et al.*, 2005). The progeny plants of this line were completely resistant to BNYVV by foliar rub-inoculation. ELISA and RT-PCR analysis failed to detect the virus accumulation in the inoculated and upper leaves up to 40 days post inoculation (dpi). Tissue imprinting assay revealed that virus could not accumulate in inoculated leaves, whereas virus accumulated at high levels in the whole area of inoculated leaves of nontransgenic plants (Fig. 1A). Furthermore, we examined whether this transgenic plant line has resistance to BNYVV by fungus-inoculation. At 12, 18, and 24 days after zoospores inoculation, virus infection of the roots was assessed by ELISA and RT-PCR. Both assays detected virus accumulation in roots of RT24-2 progeny plants although the virus titer was very

low compared with nontransgenic plants. Tissue imprinting assay of fungus-inoculated roots showed that virus could accumulate in roots of RT24-2 plants however, it was very restricted compared to accumulation in roots of nontransgenic plants (Fig. 1B).

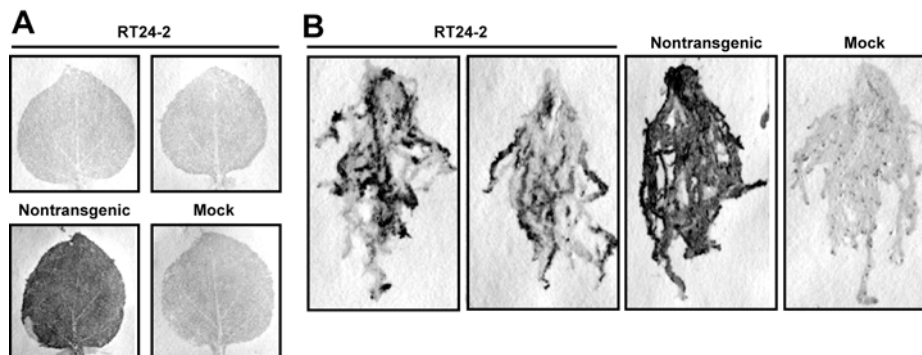

Figure 1. Tissue imprinting assay of virus accumulation using an antibody specific for CP of BNYVV. **A**, Inoculated leaves by foliar rub-inoculation. **B**, fungus-inoculated roots.

We compared the levels of virus accumulation in leaves and roots of transgenic plants showing recovery phenotype (line RT8-2) by ELISA and tissue imprinting assay. At 28 dpi, virus still accumulated at high levels in roots, whereas no virus accumulation was detected in upper asymptomatic leaves. In the next experiments, accumulation levels of transgene transcripts were analyzed by semi quantitative RT-PCR. The levels of transgene transcript accumulation were reduced in roots and in both lower symptomatic leaves (at positions 4 and 5 above inoculated leaf) and upper asymptomatic leaves (at positions 8 and 9 above inoculated leaf) (Fig 2, lane 8-16). Thus, different with leaves, decrease of transgene transcripts accumulation in roots was not accompanied by decrease in virus accumulation.

The amount of transgene mRNAs and transgene-derived siRNAs in roots and leaves of RT24-2 plants were compared. Transgene mRNAs accumulated to higher levels in roots than in leaves. By contrast, transgene-derived siRNAs accumulated at higher levels in leaves than in roots. The similar results were observed when the viral RNAs and virus-derived siRNAs accumulation in roots and leaves of nontransgenic *N. benthamiana* plants were examined. Roots contained higher levels of viral RNA accumulation and was inversely related with the levels of siRNA accumulation.

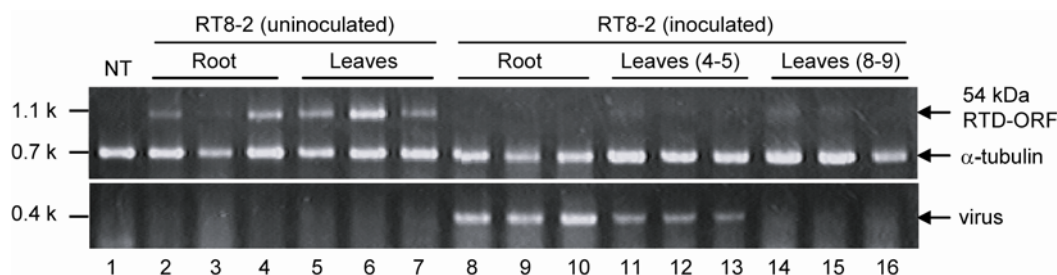

Figure 2. semi quantitative RT-PCR analysis of transgene mRNA accumulation in roots and leaves of transgenic plants showing recovery.

RNA silencing in plants is closely associated with DNA methylation, therefore, we analyzed transgene DNA methylation levels in roots and leaves of RT24-2 plants. The first analysis used was methylation-sensitive restriction endonuclease digestion and then DNA gel blot. *Sau96I* and *HpaII* restriction enzymes which are sensitive to cytosine methylation at non-symmetrical CpNpN and symmetrical CpG contexts, respectively, were used. Digestion with *Sau96I* showed that transgene DNA was methylated at lower levels in roots than in leaves, whereas in digestion with *HpaII*, no difference of DNA methylation levels between those tissue was observed. These results indicate that transgene DNA methylation levels at non-symmetrical sites were lower in roots than in leaves, while methylation levels at symmetrical sites were at the same levels. To provide data on the methylation status of more number of cytosine residues, we employed the bisulphite sequence method which makes use of conversion of nonmethylated cytosine into uracil by sodium bisulphite. Bisulphite sequence analysis showed that the percent of cytosine methylation at CpNpN, CpNpG and CpG contexts for roots was 32%, 74% and 75%, respectively, while leaves were 52%, 74% and 76%, respectively. Thus, the cytosine methylation analysis using bisulphite sequencing were consistent with the analysis using methylation-sensitive restriction enzyme digestion.

This study demonstrated that RNA silencing-mediated resistance to BNYVV is less effective in roots than in leaves. Viruliferous zoospores of *P.betae* were able to inoculate the virus to roots of the plant that are immune to foliar rub-inoculation. Analyses of the hallmarks of RNA silencing in plants such as degradation levels of target RNA, accumulation of siRNAs and transgene DNA methylation highly indicated that this phenomenon is due to the lower RNA silencing activity in roots than in leaves. Further study is needed to find out what the cause of lower silencing activity in roots.

References

- Andika, I.B., Kondo, H., and Tamada, T. 2005. Evidence that RNA silencing-mediated resistance to *Beet necrotic yellow vein virus* is less effective in roots than in leaves. *Mol. Plant-Microbe Interact.* **18**, 194-204.
- Chomczynski, P., and Sacchi, N. 1987. Single-step method of RNA isolation by acid guanidinium thiocyanate-phenol-chloroform extraction. *Anal. Biochem.* **162**,156-159.
- Goldbach, R., Bucher, E., and Prins, M. 2003. Resistance mechanisms to plant viruses: an overview. *Virus Res.* **92**, 207-212.
- Murray, M. G., and Thompson, W. F. 1980. Rapid isolation of high molecular weight plant DNA. *Nucleic Acids Res.* **8**, 4321-4325.
- Paulin, R., Grigg, G.W., Davey, M.W., and Piper, A.A. 1998. Urea improves efficiency of bisulphite-mediated sequencing of 5'-methylcytosine in genomic DNA. *Nucleic Acids Res.* **26**, 5009-5010.
- Tamada, T. 1999. Benyvirus. Pages 154-160 in: Encyclopedia of Virology. 2nd ed. R. G. Webster and A. Granoff, eds. Academic Press, London.
- Tamada, T., and Abe, H. 1989. Evidence that beet necrotic yellow vein virus RNA 4 is essential for efficient transmission by the fungus *Polymyxa betae*. *J. Gen. Virol.* **70**, 3391-3398.
- Tamada, T., and Kusume, T. 1991. Evidence that the 75K readthrough protein of beet necrotic yellow vein virus RNA-2 is essential for transmission by the fungus *Polymyxa betae*. *J. Gen. Virol.* **72**, 1497-504.
- Vance, V., and Vaucheret, H. 2001. RNA silencing in plants-defense and counterdefense. *Science* **292**, 2277-2280.

MARKER BASED STRATEGIES IN BREEDING FOR BYMOVIRUS RESISTANCE IN BARLEY

Frank Ordon¹, Kay Werner², Antje Habekuß¹, Ilona Krämer¹, Dragan Perovic¹, Nils Stein³, Andreas Graner³, Wolfgang Friedt²

¹Institute of Epidemiology and Resistance Resources, Federal Centre for Breeding Research on Cultivated Plants, Theodor-Roemer-Weg 4, 06449 Aschersleben, Germany,

²Institute of Crop Science and Plant Breeding I, Justus-Liebig-University, Heinrich-Buff-Ring 26-32, 35392 Giessen, Germany,

³Institute of Plant Genetics and Crop Plant Research (IPK), Corrensstr. 3, 06466 Gatersleben, Germany,

Summary

In Europe barley yellow mosaic virus disease is caused by at least two strains each of BaYMV and BaMMV. In the barley genome several loci (e.g. *rym4/5*, *rym9*, *rym11*) - in some cases carrying alleles conferring resistance to specific strains, only - have been tagged by molecular markers and recently closely linked markers for *rym11*, *rym15* and the BaYMV/BaYMV-2 resistance of the variety 'Chikurin Ibaraki 1' have been developed. Closely linked markers are efficient tools for screening germplasm collections for the presence of already known resistance genes, for marker based selection procedures, marker assisted backcrossing and especially pyramiding of resistance genes. In the present paper results on marker development and their use in breeding barley for resistance to the barley yellow mosaic virus complex are given.

Introduction

Because of its constant spread and high yield losses frequently observed in susceptible winter barley crop, barley yellow mosaic virus disease has become a serious threat to winter barley cultivation in Europe. The disease is caused by two different bymoviruses, i.e. *Barley Mild Mosaic Virus* (BaMMV) and *Barley Yellow Mosaic Virus* (BaYMV). In Europe at least two strains each of BaMMV and BaYMV have been identified so far. (Huth and Adams 1990, Hariri et al. 2003, Kanyuka et al. 2004, Huth et al. 2005, Habekuß et al. this volume). Due to the fact that both viruses are transmitted by the soil-borne fungus *Polymyxa graminis* Led. chemical measures against the disease are neither efficient nor economic and growing of resistant cultivars has to be considered as the only possibility to ensure winter barley cultivation in the growing area of infested field. Therefore, breeding for resistance to the barley yellow mosaic virus complex has become an important goal in barley breeding which can be deduced from the data given in Table 1. In 1986 out of 43 released winter barley cultivars in Germany only 6 were resistant (BaMMV/BaYMV) which were considerably lower yielding than susceptible ones. In 2005 75 winter barley cultivars were released of which 48 are resistant to BaMMV/BaYMV and 4 in addition to BaYMV-2. On average these are higher than the susceptible cultivars. (Table. 1).

Table 1. Number of released resistant and susceptible winter barley cultivars in Germany and their average yield (Anonymous 1986, 2005)

Year	No. cultivars		Yield*	
	resistant cvs.	susceptible cvs.	resistant cvs.	susceptible cvs.
1986	6	37	4.3	5.6
2005	52	23	6.7	6.1

*1=minimum, 9=maximum

Resistance of released European barley cultivars is still on a very narrow genetic base, i.e. *rym4* and *rym5* located on chromosome 3HL (Graner and Bauer 1993, Graner et al. 1999) which represent different alleles of the translation initiation factor 4e (*Hv-eif4e*, Stein et al. 2005). However, additional resistance genes are known (for overview cf. Ordon et al. 2005) and may be exploited by breeding.

Development and use of molecular marker in breeding barley resistant to bymoviruses

Based on the screening of large germplasm collections (Ordon et al. 1993) followed by genetic analysis (Götz and Friedt 1993, Ordon and Friedt 1993) several recessive resistance genes against the barley yellow mosaic virus complex have been mapped on chromosomes 1H, 3H, 4H, 5H, and 6H as well as two dominant resistance genes derived from *H. bulbosum* on chromosomes 2H and 6H (for overview cf. Ordon et al. 2005). Respective molecular markers which have been developed recently, e.g. for the independently inherited BaMMV (6H) and BaYMV/BaYMV-2 (5H) resistance of the Japanese variety 'Chikurin Ibaraki 1' (Fig. 1, Werner et al. 2003, Le Gouis et al. 2004), facilitate screening of germplasm collections for the presence of already known resistance genes, marker based selection procedures, marker assisted backcrossing and especially pyramiding of resistance genes.

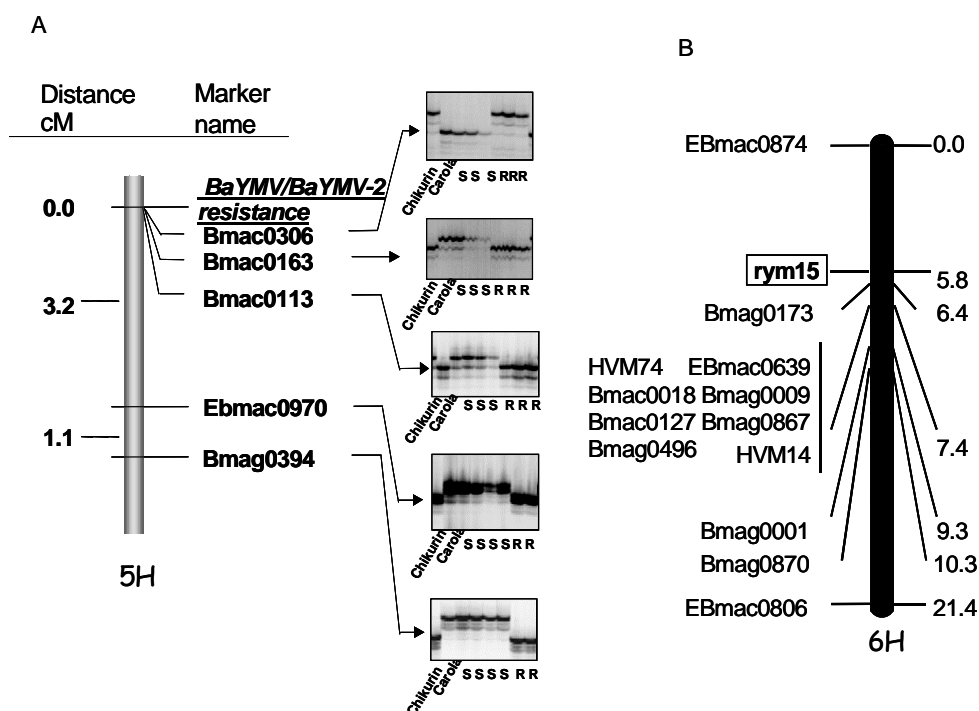

Fig. 1. Localisation of the BaYMV/BaYMV-2-resistance (A) and the BaMMV-resistance (*rym15*, B) of the variety 'Chikurin Ibaraki 1' (Werner et al. 2003, Le Gouis et al. 2004)

By analysing more than 2000 genebank accessions for resistance, 114 accessions were identified resistant to BaMMV, BaYMV and BaYMV-2. By analysing these accessions with the SSR-marker Bmac029 being closely linked to the resistance locus *Rym4/Rym5* (Graner et al. 1999, Pellio et al. 2005) 20 accessions have been identified not showing the Bmac029 allele indicative for *rym5*. As these genotypes are valuable sources for the detection of genes conferring resistance to BaMMV, BaYMV and BaYMV-2 being different from *rym5*, genetic analyses and mapping of resistance derived from these accessions based on DH-lines was started. Analyses are still in progress but employing bulked segregant analyses the BaYMV/BaYMV-2 resistance of one completely resistant accession was located on chromosome 5H and a gene exclusively effective against BaMMV was located on chromosome 3HL. Further analyses will reveal whether the gene on chromosome 5H is allelic to the BaYMV/BaYMV-2 resistance gene located in 'Chikurin Ibaraki 1' (Fig. 1) and whether the BaMMV resistance gene on chromosome 3HL is a new allele of the *Rym4/Rym5* locus or a different gene. However, these results elucidate that closely linked markers or - in the future even more efficiently - markers derived directly from respective resistance genes (*Hv-eif4e*) are very useful in the process of identifying germplasms in genebank collections which carry new resistance genes/alleles.

Besides this, these markers are efficient tools to incorporate respective resistance genes into adapted breeding lines. For example 'Chikurin Ibaraki 1' is very low yielding and highly susceptible to lodging, winter killing and *Rhynchosporium secalis* (Ordon and Friedt 1994). Long lasting back crossing procedures are needed to combine resistance to the barley yellow mosaic virus complex with superior agronomic performance. Because all the resistance genes against the soil-borne mosaic inducing viruses derived from the primary gene pool of barley are inherited recessively, a selfing generation is needed after each backcrossing step for the phenotypic identification of resistant plants (homozygous recessive) - e.g. by mechanical inoculation of BaMMV in the greenhouse - which will be used in the next cycle. However, by co-dominant markers like SSRs heterozygous carriers of the resistant encoding allele which can be used in the next backcrossing cycle can be detected directly in F₁, thereby saving one year for each backcrossing cycle (for details cf. Ordon et al. 1999). This advantage gets even more important, for example, the case of 'Chikurin Ibaraki 1' - the BaMMV resistance is inherited independently from the BaYMV/BaYMV-2 resistance (Fig. 1), because no efficient screening for BaYMV/BaYMV-2 resistance on the single plant level in the greenhouse can be conducted. Consequently, an additional selfing step is needed to identify those genotypes which in addition to BaMMV are resistant to BaYMV/BaYMV-2. In contrast to this, the resistance encoding alleles of both loci can be easily followed simultaneously by respective molecular markers (Fig. 1), resulting in a time saving of at least two years per cycle.

The combination of resistance genes in one breeding line, i.e. pyramiding, may become of special importance in the future as many of the resistance genes known - except *rym11* - are not effective against all agents of the barley yellow mosaic virus complex, e.g. *rym4* is not effective against BaYMV-2, *rym9* not against BaYMV and BaYMV-2 and *rym5* is ineffective against BaMMV-SIL (Kanyuka et al. 2004) and the new strain of BaMMV recently identified in Germany (Huth et al. 2005, Habekuß et al. this volume). Therefore, pyramiding of resistance genes has to be considered as a useful approach for extending the usability of these resistance genes in barley breeding, e.g. the combination of *rym5*, which at the moment is the entire basis of cultivars being resistant to BaMMV, BaYMV and BaYMV-2 in Europe with *rym9* being effective against BaMMV and BaMMV-SIL (Kanyuka et al. 2004) should result in resistance against all yellow mosaic inducing viruses known in Europe. A respective programme for pyramiding has already been started in 1998 before the resistance breaking strains of BaMMV have been detected and consequently concentrated on genes for which respective markers have been available at that time, i.e. *rym4*, *rym5*, *rym9*, *rym11*. For pyramiding recessive resistance genes DH-populations are much better suited than segregating F₂ populations,

because homozygous recessive genotypes are more frequent. Using a strategy based on the marker assisted identification of plants derived from crosses of the F₁ of e.g. *rym5* x *rym9* and *rym5* x *rym11* being homozygous at the resistance locus in common (*rym5*) and heterozygous at the others as donor plants for DH-line production, all three gene and possible two gene combinations have been identified by markers in the resulting DH-population (for details cf. Werner et al. 2005). First results of lines carrying *rym5* and *rym9* according to respective markers give hint that these are resistant to all agents of the barley yellow mosaic virus complex known so far in Europe (H. Jaiser, pers. comm).

The results presented elucidate that molecular markers, besides their use in marker assisted selection in early generations independently from symptom expression in the field, (Schiemann and Backes 2000), are efficient tools in breeding barley for resistance to the barley yellow mosaic virus complex.

The authors thank Kirsten Striedelmeyer, Natalia Lest, Christiane Happel, Marlies Weilepp, Susanne Thiele, Edith Herrmann and Roland Kürschner for excellent technical assistance. This work has been financed by the German Research Foundation (DFG, grants Gr 1317/3-2, OR 72/2-2 to F.O.) and the Bundesministerium für Verbraucherschutz, Ernährung und Landwirtschaft (BMVEL) and by the Gemeinschaft zur Förderung der privaten deutschen Pflanzenzüchtung (GFP) grant number G82/98 HS.

References

- Anonymous (1986, 2005). Beschreibende Sortenliste für Getreide, Mais, Ölfrüchte, Leguminosen (großkörnig), Hackfrüchte (außer Kartoffeln). Bundessortenamt (Hrsg.) Landbuchverlagsgesellschaft, Hannover.
- Götz, R., and Friedt, W. (1993). Resistance to the barley yellow mosaic virus complex – Differential genotypic reactions and genetics of BaMMV-resistance of barley (*Hordeum vulgare* L.). *Plant Breeding* **111**, 125-131.
- Graner, A., and Bauer, E. (1993). RFLP mapping of the ym4 virus resistance gene in barley. *Theor. Appl. Genet.* **86**, 689-693.
- Graner, A., Streng, S., Kellermann, A., Schiemann, A., Bauer, E., Waugh, R., Pellio, B., and Ordon, F. (1999). Molecular mapping of the *rym5* locus encoding resistance to different strains of the Barley Yellow Mosaic Virus Complex. *Theor. Appl. Genet.* **98**, 285-290.
- Hariri, D., Meyer M., and Prud'homme H. (2003). Characterization of a new barley mild mosaic virus pathotype in France. *Eur. J. Pathol.* **109**, 921-938.
- Huth, W., and Adams M. J. (1990) Barley Yellow Mosaic Virus (BaYMV) and BaYMV-M: two different viruses. *Intervirology* **31**, 38-42.
- Huth, W., Habekuß, A., and Ordon F. (2005). Neue Stämme des Barley mild mosaic virus auch in Deutschland. *Nachrichtenbl. Deut. Pflanzenschutzd.* **57**, 152-154.
- Kanyuka, K., McGrann, G., Alhudaib, G., Hariri, D., and Adams M.J. (2004). Biological and sequence analysis of a novel European isolate of Barley mild mosaic virus that overcomes the barley *rym5* gene. *Arch. Virol.* **149**, 1469-1480.
- Le Gouis, J., Devaux, P., Werner, K., Hariri, D., Bahrman, N., Beghin, D., and Ordon F (2004). *Rym15* from the Japanese cultivar 'Chikurin Ibaraki 1' is a new Barley Mild Mosaic Virus (BaMMV) resistance gene mapped on chromosome 6H. *Theor. Appl. Genet.* **108**, 1521-1525.
- Ordon, F., and Friedt, W. (1993). Mode of inheritance and genetic diversity of BaMMV resistance of exotic barley germplasms carrying genes different from 'ym4'. *Theor. Appl. Genet.* **86**, 229-233.
- Ordon, F., and Friedt, W. (1994). Agronomic traits of exotic barley germplasms resistant to soil-borne mosaic-inducing viruses. *Genetic Resources and Crop Evolution* **41**, 43-46.

- Ordon, F., Götz, R., and Friedt, W. (1993). Genetic stocks resistant to barley yellow mosaic viruses (BaMMV, BaYMV, BaYMV-2) in Germany. *Barley Genet. Newsl.* **22**, 46-49.
- Ordon, F., Schiemann, A., Pellio, B., Dauck, V., Bauer, E., Streng, S., Friedt, W., and Graner, A. (1999). Application of molecular markers in breeding for resistance to the barley yellow mosaic virus complex. *J. Plant Diseases and Protection* **106**, 256-264.
- Ordon, F., Ahlemeyer, J., Werner, K., Köhler, W., Friedt, W. (2005). Molecular assessment of genetic diversity in winter barley and its use in breeding. *Euphytica* (in press)
- Schiemann, A., and Backes, G. (2000). The use of molecular markers in practical barley breeding. In: *Proc 8th Int Barley Genet Symp Vol 3. Adelaide Australia* pp 42-44.
- Stein, N., Perovic, D., Kumlehn, J., Pellio, B., Stracke, S., Streng, S., Ordon, F., and Graner, A. (2005). The eukaryotic initiation factor of translation 4E confers multiallelic recessive bymovirus resistance in *Hordeum vulgare* (L.). *The Plant Journal* **42**, 912-922.
- Werner, K., Friedt, W., Laubach, E., Waugh R., and Ordon, F. (2003). Dissection of resistance to soil-borne yellow mosaic inducing viruses of barley (BaMMV, BaYMV, BaYMV-2) in a complex breeders cross by SSRs and simultaneous mapping of BaYMV/BaYMV-2 resistance of 'Chikurin Ibaraki 1'. *Theor. Appl. Genet.* **106**, 1425-1432.
- Werner, K., Friedt, W., and Ordon, F. (2005). Strategies for pyramiding resistance genes against the barley yellow mosaic virus complex (BaMMV, BaYMV, BaYMV-2). *Mol. Breeding* (in press).

TRANSLOCATION RESISTANCE - MOST EFFECTIVE TYPE OF RESISTANCE TO FUROVIRUSES OF WHEAT

W. Huth(1), D.E. Lesemann(1) and R. Goetz(1;2)

(1) c/o Federal Biological Research Centre, Institute for Plant Virology, Microbiology and Biosafety, Messeweg 11/12, D-38104 Braunschweig, w.huth@bba.de.

(2) FR.STRUBE Saatzucht KG Söllingen

Summary

Furoviruses belong to the most serious pathogens of cereals. From both furoviruses *Soil-borne cereal mosaic virus* (SBCMV) and *Soil-borne wheat mosaic virus* (SBWMV) mainly the first is far spread in several European countries. Yield losses caused by them can only be avoided by growing resistant cultivars. Several cultivars of wheat with different genetic backgrounds are as described being resistant. When grown on totally infested fields, these cultivars remain visually healthy. No viruses can be detected serologically in sprouts or in leaves. However, these cultivars became infected and developed with serious leaf symptoms when furoviruses were inoculated mechanically. Serological and electronmicroscopical analysis showed that asymptomatic cultivars grown in infested fields were infected by furoviruses. These results indicate that resistant cultivars can be sensitive to furoviruses. When naturally infected viruses are multiplied at least in roots of resistant cultivars. Virus multiplication in roots as well as virus movement from roots into leaves depend on the degree of resistance as well as environmental conditions. For this type of resistance the name translocation resistance has been proposed. Nevertheless; translocation resistance is generally stable in both furoviruses SBCMV and SBWMV.

Introduction

Soilborne cereal mosaic virus (SBCMV) and *Soilborne wheat mosaic virus* (SBWMV) are members of the genus *Furovirus*. The genus *Furovirus* consists of rigid rod-shaped viruses with bipartite positive-sense RNA genomes which infect gramineous plants and are transmitted by *Polymyxa graminis*. SBCMV is common in European countries including France, Italy and Germany and occurs also in Denmark, Poland, Belgium and UK. In Europe, SBWMV was found only in a field near Heddesheim, Germany. Both viruses cause a serious disease of wheat, rye and triticale. Yield losses caused by these viruses range between 10 and 80% depending on cultivars resistance. Virus particles can survive in resting spores of *P. graminis* in the soil for over 10 years. Due to the persistent nature of the virus within the soil, growing resistant varieties represents the only economical means of control.

Investigations have been conducted for more than 10 years on over 300 different cultivars of wheat, rye and triticale; as a result a special type of resistance to soil-borne furoviruses was identified. The characteristic properties of this type resistance are described as follows.

Results and Discussion

The basis for identification of resistance to the furoviruses were observations of a large number of cultivars for several years on fields highly and homogeneously infested by viruses in regions with different environmental conditions. Homogeneity of cultivars used and similar reactions of all individual plants of each cultivar was necessarily presupposed for the selection

of resistance. Therefore, homogenic reaction of plants belonging to one cultivar was used as criteria for resistance properties.

Translocation resistance

Naturally infected cultivars range from highly susceptible developing strong leaf symptoms and showing growth reductions to highly resistant showing no symptoms (Table 1). When grown on totally infested fields, resistant cultivars remain visually healthy without showing leaf symptoms, and no viruses can be detected serologically in leaves. Some of the resistant cultivars, mainly progenies of *Moulin*, have been available on the French market for several years and are sown in fields totally infested by furoviruses without yield losses.

Table 1:
Comparison reactions of cultivars translocation resistant and susceptible to furoviruses

Cultivar	Field observations			mechanic. inoculation		
	Symptoms*	Virus detected**		Symptoms*	Virus detected**	
		in leaves	in roots		in leaves	in roots
<i>resistant cultivars</i>						
<i>Caesar</i>	-	-	+	+	+	+
<i>Charger</i>	-	-	+	+	+	+
<i>Colfiorito</i>	-	-	+	+	+	+
<i>not resistant cultivars</i>						
<i>Cezanne</i>	+	+	+	+	+	+
<i>Ephoros</i>	+	+	+	+	+	+

* = agreeing results on fields near Heddeshheim (D; SBWMV), Walternienburg (D; SBCMV), Guilly (F; SBCMV) and Bologna (I; SBCMV)

** = serologically detected via TPIA and/or by electron microscopy

- = no leave symptoms, no virus detected; + = leave symptoms; virus detected

Although leaves are free of symptoms and the plant appears visually healthy, it could be shown that also resistant cultivars are in principle sensitive to furoviruses. In roots of more than 95% of these cultivars, furoviruses were detected serologically using tissue print immuno assay and electron microscopy (see Table 1). In most roots the content of virus is rather low. Sometimes only few particles are detected by electron microscopically. Furthermore, in contrast to susceptible cultivars viruses were evident in roots during late stages of plant development. Viruses were also detected in tissues between roots and the base of sprouts but very rarely in sprouts and leaves of symptomless plants.

Serological and electronmicroscopical analysis in 2004 showed that although symptomless same cultivars grown in infested fields were infected by furoviruses. These results became confusing by analysis in 2005. Although grown on the same experimental fields, furoviruses could neither be detected in roots nor in leaves of these cultivars. It seems to be possible that the different reaction of the cultivars depends on different environmental conditions in these two years.

From these results it is concluded that resistant cultivars are in principle sensitive to furoviruses when infected naturally. The mechanism of resistance of these cultivars were based on suppressed virus multiplication in roots as well as suppressed virus movement into leaves. Therefore, from this property of cultivars to furoviruses the name translocation resistance was proposed (Huth, 1997).

Mechanical inoculation

When highly resistant cultivars may multiply furoviruses in roots than plants of the same cultivars should be able multiplying viruses also in leaves when viruses are inoculated mechanically. Using crude sap of plants infected with SBCMV or SBWMV respectively for inoculation plants of resistant cultivars became infected and show strong leaf symptoms (Table 1).

Screening for resistance

The gradual different reactions of cultivars to infections by furoviruses which depends on environmental factors characterise translocation resistance as a quantitative polygenic property. They have been considered in screening of cultivars for resistance. Results from trials under controlled conditions in climate chambers may not always agree with those received on fields under natural inoculation conditions.

Furthermore, mechanical inoculation of furoviruses is not suitable for screening of resistance in wheat, rye or triticale. Because also plants of cultivars grown on infested fields without leaf symptoms can be infested by mechanical inoculation.

Therefore, trials for several years on fields which are homogeneously and totally infested by furoviruses are predominantly recommended for resistance screening. Failure of foliar symptoms during all stages of plant development is the only criterion for resistance of cultivars if grown under different environmental conditions.

References

Huth, W., 1997: Resistance – Toleranz: Neu definieren. Ber. 48. Arbeitstagung Vereinig. Österreich. Pflanzenzüchter. Gumpenstein 25.-27. Nov. 1997, 129-133.

BREAKDOWN OF *Rz1* IN INDIVIDUAL PLANTS OF RHIZOMANIA TOLERANT CULTIVARS

Rush, C.M., K. Steddom, D. Jones, and R. Acosta-Leal

TAES Research and Extension Center, 6500 Amarillo Blvd. W., Amarillo, TX, 79106, USA

Summary

In 2002, severe symptoms of rhizomania began to develop on sugar beets from the Imperial Valley of California in fields planted to rhizomania resistant cultivars. Subsequent studies verified that a new strain of BNYVV capable of overcoming the Holly *Rz1* gene had developed. In 2003, rhizomania began to develop in irregularly shaped spots and on individual beets in Minnesota fields planted to resistant cultivars. Studies were initiated to determine the cause of rhizomania development in Minnesota, and to determine whether a new strain of BNYVV had developed. Individual beets (Blinkers) exhibiting fluorescent yellow foliage, characteristic of rhizomania, were collected from several rhizomania resistant cultivars that had been planted in a rhizomania strip trial, and compared to beets that appeared disease free. Blinkers had significantly higher disease ratings, reflectance at 555nm, and ELISA values than healthy beets and significantly lower sucrose content. When only blinkers were evaluated, 42% possessed the Holly *Rz1* gene. Those possessing *Rz1* had higher ELISA values but disease ratings were not significantly different from blinkers testing negative for *Rz1*. This indicated that the *Rz1* gene in blinkers had no efficacy in controlling rhizomania and had been overcome by BNYVV. Subsequent comparisons of multiple isolates of BNYVV from the Imperial Valley of California and from blinkers in Minnesota revealed that the amino acid composition of the RNA 3 P25 ORF varied. Most isolates from the Imperial Valley contained a VLHG motif, and all possessed an L at position 68, while all blinkers possessed either a VCHG or ACHG motif. It is unknown whether these are associated with the breakdown of disease resistance in rhizomania resistant cultivars.

Introduction

In 2002, plants in a field in the Imperial Valley of California that was planted to a rhizomania tolerant cultivar began to express symptoms of rhizomania. Large strips of diseased plants occurred across the field and it was soon verified that BNYVV had overcome genetic resistance (Liu, et. al., 2005). In other regions of the US, individual plants in fields planted to rhizomania tolerant cultivars have also become infected by BNYVV and developed diagnostic symptoms of severe rhizomania. These individual symptomatic plants in fields of apparently healthy plants are called "blinkers". Although patterns of disease development have varied between California fields and those in other production regions in the US, the breakdown of genetic resistance has caused considerable concern among those involved in sugar beet production.

In the Imperial Valley of California, soil samples were taken in fields planted to rhizomania tolerant cultivars from areas exhibiting typical symptoms of rhizomania. BNYVV was baited from the soil using rhizomania resistant plants and then the virus was extracted and purified from the infected bait plants. Genetic analysis of the Imperial Valley strain of BNYVV (CIV-BNYVV) indicated that it was 99% identical to standard isolates of BNYVV that cannot overcome the *Rz1* gene. Isolates did not contain an RNA 5 as described by others (Koenig and Lennefors, 2000; Miyanishi, et. al., 1999) This suggested that the ability of CIV-BNYVV to overcome the *Rz1* gene was the result of a minor genetic change in the virus and not a major shift in genetic make up due to recombination, reassortment, or a major deletion. Because of

the natural variability among isolates of BNYVV, identification of the specific mutation that allows CIV-BNYVV isolates to overcome the *Rz1* gene may be difficult.

In Minnesota, in fields planted to rhizomania tolerant cultivars, disease primarily has been observed on individual plants and not in large strips or spots in the field. It is well known that in the increase of genetically resistant seed there is always a low percentage of seed that, for various reasons, do not possess the gene that confers the resistance. It is also recognized that there are a number of other reasons that could account for disease development in individual plants. Therefore, the primary objective of this study was to determine whether the blinkers actually possessed the *Rz1* gene. The second objective was to compare isolates of BNYVV from California and Minnesota for genetic similarities.

Materials and Methods

Blinkers and apparently healthy beets were collected from three strip trials in Minnesota near, Crookston, Moorhead, and Willmar. At each field location, a minimum of eight blinkers and two apparently healthy beets were collected from each cultivar represented in the strip trial. Rhizomania tolerant cultivars included in the test included Beta 1305 and 4818, Crystal 826, Hilleshog 2411, 2463, 2467, and 2469, Seedex 0831 and Result, and Vanderhave 46177 and 46519. Beta 3800 and Crystal 725 were included as susceptible controls. Each individual beet was rated for rhizomania severity on a 0 – 4 scale, with 0 = healthy, no symptoms and 4 = severe rhizomania symptoms, such as stunting, constriction and proliferation of lateral roots, and roots with fungal disease symptoms were discarded. Leaf chlorosis was quantified using an integrating sphere hyperspectral radiometer and leaf, root and rhizosphere soil samples were collected and sent to the plant pathology laboratory in Bushland. Root samples were tested by DAS-ELISA for presence of BNYVV and, after freeze-drying, leaf samples were tested for presence or absence of the *Rz1* gene. Percent sucrose was determined for blinkers and apparently healthy beets for each cultivar collected at each field location.

In subsequent studies, BNYVV was baited, using rhizomania resistant sugar beet cultivars, from rhizosphere soils of sugar beets that tested positive for *Rz1* and had a high rhizomania root disease rating. Total RNA was extracted from root tissue (0.1 – 0.2 g) utilizing the RNAqueous- Midi kit (Ambion, Inc.). First strand cDNA was generated using an oligo(dT) primer and the P25 ORF of RNA 3 was amplified by PCR using specific primers, ttaatccaagtacctcgtct (forward) and ttgaaattgtgataactctaa (reverse). The 1,013 bp PCR product was directly cloned into pCR2.1 and individual clones were submitted for DNA sequencing. Nucleotide sequence data from these clones was compared to sequences from BNYVV isolates obtained from the Imperial Valley and to sequences of BNYVV P25 in GenBank.

Results and Discussion

The rhizomania strip trials used in this study provided an ideal location for collecting samples from a large number of rhizomania tolerant cultivars. Sites for the strip trials were initially selected because of anticipated heavy, relatively uniform disease pressure. Disease was most severe at Moorhead and least at Willmar, but disease incidence was adequate at each site and replication of each cultivar in the test provided easy access to blinkers.

Use of radiometry to quantify leaf chlorosis proved to be an effective technique (Fig.1). Plotting reflectance at wavelengths from 400 – 700 nm revealed that differences between apparently healthy beets and blinkers were best observed at 555nm. At this wavelength, blinkers displayed significantly higher percent reflectance than healthy beets but differences between blinkers with and without the *Rz* gene were not always significant.

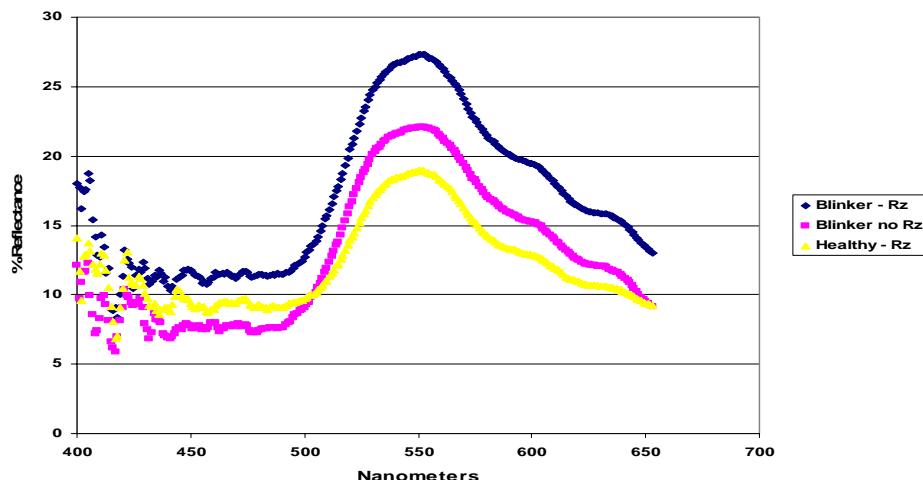

Figure 1. Percent reflectance from leaf tissue obtained from blinkers and healthy beets.

Differences between apparently healthy beets and blinkers were, for the most part, as expected (Table 1). A significantly greater percentage of healthy plants tested positive for the *Rz* gene, compared to the blinkers, but a significantly lower percentage of the healthy plants tested positive for BNYVV in the ELISA test. Blinkers had a significantly higher disease rating and higher reflectance readings at 555nm than the apparently healthy beets and also greatly reduced sucrose content.

Table 1. Comparisons between healthy and blinkers for several variables

Plant Type	Disease Rating	Reflectance (555nm)	ELISA (% Pos.)	%Sucrose
Blinkers	2.95	26.58	88%	13.98
Healthy	1.14*	19.04*	44%*	15.67*

* Significant at $p=0.05$

However, when comparing disease ratings between blinkers with or without the *Rz* gene, there was no difference (Table 2). This indicated that presence of the *Rz* gene in these plants was not conferring any resistance to BNYVV and supports the conclusion that new virulent strains may be involved. Furthermore, large spots of diseased plants observed in the 2005 crop verify that disease incidence is not a seed production problem and also supports the argument for new strains.

Table 2. Comparisons between blinkers with and without the *Rz* gene

<i>Rz</i> Category	% <i>Rz</i>	ELISA (% Pos.)	ELISA Value	Disease Rating
<i>Rz</i> Negative	57	95%	1.80	2.88
<i>Rz</i> Positive	42*	80%*	0.98*	2.93ns

* Significant at $p=0.05$

RNA 3 of BNYVV was selected to evaluate as an initial site of genetic variability because it has been shown that RNA 3 is associated with symptom expression and pathogenicity (Jupin, et. al., 1992; Rush, 2003). Comparison of BNYVV RNA 3 P25 nucleotide sequences from California and Minnesota isolates and accessions submitted to GenBank showed a high degree

of sequence homology. However, all CIV isolates had an L residue at amino acid position 68 while those from Minnesota all possessed a C residue (Fig. 2). Additional study must be conducted to determine whether this substitution is truly descriptive of isolates from each geographic region and whether it is involved with the ability of these strains to overcome genetic resistance.

The results from this study are inconclusive and do not prove the existence of a new virulent strain. It is well known that several factors other than mutation, such as high inoculum density or the combination of minor genes, can impact severity of rhizomania. Additional study is needed to determine the etiology of disease in rhizomania resistant cultivars in Minnesota sugar beet production areas.

CIV	61-FRGLLCA L HGPYCGFRALCRVMLCSLPRLC-90
Tam	61-FRGLLCV L HGPYCGFRALCRVMLCSLPRLC-90
Mag	61-FRGLLCV L HGPYCGFRALCRVMLCSLPRLC-90
Ch	61-FRGLLCV L HGPYCGFRALCRVMLCSLPRLC-90
B83	61-FRGLLCV C HGPYCGFRALCRVMLCSLPRLC-90
WT	61-FRGLLCA C HGPYCGFRALCRVMLCSLPRLC-90
Gle	61-FRGLLCA C HGPYCGFRALCRVMLCSLPRLC-90

Fig.2. Amino acid sequence for four BNYVV isolates from the Imperial Valley of California and three from Minnesota. All CIV isolates possess an L substitution at position 68, while isolates from Minnesota have a C.

Acknowledgements

We wish to thank Dr. Larry Campbell, USDA-ARS Fargo, ND for sugar analysis and Al Cattanach, American Crystal, and Mark Bredehoeft and Steve Roehl, Southern Minnesota Sugar Beet Cooperatives for field and technical support. We also thank the Minnesota/North Dakota R&E Board and the BSDF for partial funding of this project.

References

- Jupin I, Guilley H, Richards KE, Jonard G. 1992. Two proteins encoded by *Beet necrotic yellow vein virus* RNA 3 influence symptom phenotype on leaves. *EMBO Journal* 11:479-88
- Koenig R, Lennefors BL. 2000. Molecular analyses of European A, B and P type sources of *Beet necrotic yellow vein virus* and detection of the rare P type in Kazakhstan. *Arch. Virol.* 145:1561-70
- Liu, H.-Y., Sears, J.L., and Lewellen, R.T. 2005. Occurrence of Resistance Breaking *Beet necrotic yellow vein virus* of Sugar Beet. *Plant Dis.* 89:464-468.
- Miyanishi M., Kusume T., Saito M., Tamada T. 1999. Evidence for three groups of sequence variants of *Beet necrotic yellow vein virus* RNA5. *Arch. Virol.* 144: 879-92
- Rush, C.M. 2003. Ecology and Epidemiology of Benyviruses and Plasmodiophorid Vectors. *Annual Review Phytopathology* 41:567 -592.

REACTION OF 111 CULTIVARS TRITICUM DURUM DESF. OF VARIOUS ORIGINS TO SOILBORNE CEREAL MOSAIC VIRUS

V. Vallega¹, C. Rubies Autonell², C. Ratti², M. Maccaferri², R. Tuberosa², M. C. Sanguineti²

¹C.R.A., Experimental Institute for Cereal Research, Via Cassia 176, 00191 Rome, Italy.

²Department of Agroenvironmental Science and Technology, University of Bologna, Viale Fanin 44, 40127 Bologna, Italy

Summary

One-hundred and eleven cultivars of durum wheat (*Triticum durum* Desf.) from various origins were grown over two seasons near Bologna (Italy) in a field with natural inoculum sources of *Soilborne cereal mosaic virus* (SBCMV), and evaluated for resistance on the basis of symptom severity expression using DAS-ELISA. None of the cvs. analysed proved immune, but a number of them proved highly resistant. Amongst the latter, a high proportion were derived from cv. Edmore. The data collected should prove useful for breeders and farmers, as well as for investigating the existence of pathogenic differences between SBCMV and *Soilborne wheat mosaic virus* (SBWMV).

Introduction

Soilborne wheat mosaic virus (SBWMV, Genus *Furovirus*), vectored by *Polymyxa graminis* Ledingham (Canova 1966; Estes and Brakke 1966), was first identified in the U.S. (Mc Kinney 1923) and subsequently in most of the main wheat growing areas in the world (Clover *et al.*, 1999; Wiese 1987) including northern and central Italy (Canova and Quaglia, 1960; Vallega and Rubies-Autonell, 1989). The only economically viable means of avoiding losses by SBWMV (Rubies *et al.* 2003; Vallega *et al.* 1999, 2003 and 2004), is by growing resistant cultivars. Pathogenically distinct strains of SBWMV have not been identified, and thus resistance to this pathogen is considered stable in space and time. Recent analyses, however, have shown that the nucleotide sequence of the "SBWMV" found in Italy and other European countries is different from that present in North America (Yang *et al.*, 2001; Koenig and Huth 2003); this novel taxonomic entity has been denominated (Mayo *et al.*, 2005): *Soilborne wheat cereal mosaic virus* (SBCMV). Although there exists no general agreement regarding this subdivision (Shirako *et al.* 2000, *inter alia*) nor data suggesting that SBWMV and SBCMV differ in biological characteristics, investigating the existence of pathogenic differences within and between SBWMV and SBCMV has acquired renewed interest.

Materials and Methods

The trials were sown October 27 (2002) and November 13 (2003) in a field near Bologna (Italy) with natural inoculum sources of SBCMV, and comprised 111 old and modern durum wheat cvs. representative of a large portion of the genetic diversity present in the improved durum wheat gene pool (Maccaferri *et al.* 2005). Thirty-one of these had been previously tested for SBCMV-resistance in central and / or northern Italy (Vallega *et al.* 2004). Each entry was sown in plots consisting of three 122-cm long, solid-seeded rows, distributed according to a randomized block design with two replicates. Symptom severity was scored on three dates in 2003 (March 13, April 4 and April 13) and on four dates in 2004 (March 18, March 30, April 15 and April 22), using a 0 to 4 scale (Vallega and Rubies-Autonell 1985). Virus concentration was

determined on extracts from leaves collected March 13, April 4 and April 13 in 2003, and on March 30 and April 22 in 2004, using DAS-ELISA (Vallega et al 2003) Extracts were from a bulk of the apical half of the second and third youngest leaves of 10 randomly chosen plants/plot.

Table 1 - ELISA values and symptom scores for 111 cvs. of *Triticum durum* Desf. grown in 2003 and 2004 in a field with *Soilborne cereal mosaic virus* in northern Italy.

Cultivar	ELISA value		Sympt. score	Cultivar	ELISA value		Sympt. score
	2003 ^a	2004 ^b	Mean ^c		2003 ^a	2004 ^b	Mean ^c
Acalou	1.103 ai	1.684 ad	2.3	Galadur	0.056 q	0.047 r	0.3
AC Avonlea	0.080 q	0.033 r	0.5	Gargano*	1.196 ai	1.765 ab	1.9
AC Melita	0.035 q	0.131 qr	0.5	Goldur	0.055 q	0.105 qr	0.2
AC Morse	0.051 q	0.051 r	0.8	Grandur	0.374 mq	0.937 fm	1.1
AC Navigator	0.248 nq	0.435 lr	1.0	Grazia*	1.342 ag	1.729 ac	2.8
AC Pathfinder	0.261 nq	0.995 fk	0.7	Heider	1.523 ac	1.753 ac	2.3
Agridur*	1.464 af	1.699 ad	2.9	Helidur	0.233 nq	0.510 kr	0.6
Altar 84	0.998 cj	1.674 ad	2.8	Hercules	0.049 q	0.057 qr	0.3
Anton	0.066 q	0.085 qr	0.9	Ionio*	0.102 q	0.054 r	1.0
Appio*	0.737 ho	0.440 lr	1.1	Iride*	0.040 q	0.314 nr	0.7
Appulo	0.778 hn	1.156 di	1.1	Italo*	0.079 q	0.846 gn	0.7
Aramon	1.574 ab	1.424 af	2.8	Ixos*	0.970 dj	1.693 ad	2.4
Arcalis	1.143 ai	1.209 bh	1.9	Jabato	1.386 af	1.770 ab	2.7
Arcangelo	1.343 ag	1.597 ae	1.4	Kabir	0.091 q	0.487 kr	1.6
Arcobaleno*	1.397 af	1.693 ad	2.8	Kamilaroi	0.124 q	0.440 lr	1.0
Ardente	0.215 oq	0.491 kr	0.8	Karel	1.563 ab	1.636 ad	2.4
Arstar	1.255 ah	1.661 ad	2.8	Korifla	0.090 q	0.098 qr	1.3
Auroch	0.091 q	0.573 jr	0.8	Kronos	1.074 bi	1.742 ac	3.0
Belikh 2	0.137 q	0.099 qr	0.7	Kyle	0.045 q	0.168 qr	0.9
Belzer	0.928 fl	1.681 ad	2.8	L35	0.083 q	0.148 qr	0.7
Ben	0.036 q	0.071 qr	0.7	Lakota	0.061 q	0.071 qr	0.5
Bravadur	0.064 q	0.060 qr	1.0	Langdon	0.276 nq	0.233 or	0.4
Brindur*	0.245 nq	0.240 or	0.6	Latino	0.350 mq	0.165 qr	1.2
Bronte*	1.343 ag	1.737 ac	2.3	Lira	0.139 q	1.545 ae	1.2
Capeiti 8	0.817 gm	1.192 ch	0.7	Lloyd*	0.037 q	0.274 or	0.9
Cappelli	0.304 mq	0.746 hp	0.9	Maier	0.089 q	0.235 or	1.0
Ciccio*	1.487 ae	1.641 ad	2.2	Messapia	1.651 a	1.737 ac	2.6
Colorado*	0.068 q	0.069 qr	0.5	Mexicali 75	0.323 mq	0.503 kr	0.6
Colosseo*	0.257 nq	0.953 fl	1.9	Mindum	0.316 mq	0.404 mr	0.4
Cortez	1.229 ai	1.764 ab	2.3	Mohawk	0.067 q	0.453 kr	0.6
Creso*	0.498 jq	1.304 ag	2.1	Munich	0.349 mq	0.058 qr	0.9
Don Pedro	0.066 q	0.066 qr	0.4	Nefer*	0.079 q	0.046 r	0.7
Duilio*	0.026 q	0.094 qr	1.0	Neodur*	0.033 q	0.042 r	0.5
Duraking	0.084 q	0.040 r	0.5	Ofanto*	1.509 ad	1.794 a	2.2
Durex	0.692 ip	0.095 qr	0.9	Orjaune	0.055 q	0.243 or	0.7
Durfort	0.263 nq	0.075 qr	0.4	Platani*	0.265 nq	0.949 fm	1.2
Duriac	1.605 ab	1.799 a	2.1	Plaza	0.035 q	0.082 qr	1.2
Edmore	0.053 q	0.172 qr	1.0	Plenty	0.032 q	0.121 qr	0.8
Excalibur	1.509 ad	1.760 ab	2.7	Plinio*	1.164 ai	1.708 ad	2.2

Cultivar	ELISA value		Sympt. score	Cultivar	ELISA value		Sympt. score
	2003 ^a	2004 ^b	Mean ^c		2003 ^a	2004 ^b	Mean ^c
Extradur	1.397 af	1.695 ad	2.0	Primadur	1.317 ag	1.753 ac	1.7
Flavio*	0.426 lq	0.110 qr	1.0	Produra	1.474 af	1.687 ad	2.8
Fortore*	1.526 ac	1.674 ad	2.5	Renville	0.046 q	0.065 qr	0.6
Frankodur	1.131 ai	1.730 ac	2.1	Reva	0.035 q	0.111 qr	0.9
Roqueño	1.324 ag	1.757 ab	3.2	Valbelice*	1.547 ac	1.759 ab	2.0
Rugby	0.447 kq	1.079 ej	0.5	Valforte	1.450 af	1.645 ad	3.1
Russello	0.952 ek	0.770 go	1.2	Valnova*	1.558 ab	1.781 a	3.1
San Carlo*	0.060 q	0.159 qr	0.9	Varano*	1.459 af	1.789 a	2,6
Saragolla	0.036 q	0.037 r	0.3	Vic	0.079 q	0.049 r	1.2
Sceptre	0.070 q	0.628 iq	0.6	Waha	1.571 ab	1.787 a	3.0
Semperdur	0.200 oq	0.096 qr	0.2	Wallaroi	0.315 mq	0.107 qr	0.7
Simeto*	1.230 ai	1.752 ac	2.4	WB 881	0.717 ho	0.255 or	0.7
Solex*	0.071 q	0.274 or	0.2	WB Turbo	0.075 q	0.118 qr	0.9
Svevo*	0.080 q	0.206 pr	1.0	Yallaroi	0.154 pq	0.096 qr	0.8
Tacna	1.487 ae	1.765 ab	2.7	Yuma	0.071 q	0.227 or	0.1
Tetradur	0.312 mq	0.088 qr	0.5	MEAN	0.593	0.792	1.4
Topdur	0.305 mq	0.050 r	0.2	MIN	0.026	0.033	0.1
Trinakria	1.053 bi	1.230 ah	1.4	MAX	1.651	1.799	3.2

^aMean of three collection dates; ^bMean of two collection dates; ^cMean of two seasons ; * Cultivars tested against SBCMV also in previous trials.

Results and Discussion

Mean ELISA absorbance values of the cultivars assayed ranged from 0.026 to 1.651 in 2003, and from 0.033 to 1.799 in 2004 (Table 1). Disease pressure was distinctly higher in the second season, as testified by the overall means for ELISA absorbance (0.792 vs. 0.593) and symptom severity (1.6 vs. 1.1). Simple correlation coefficients between ELISA values and symptom scores ($r=0.827$ in 2003, and $r=0.890$ in 2004), and between data collected in different seasons ($r=0.911$ for ELISA, and $r=0,848$ for symptoms) were highly significant ($P=0.01$). The results collected for the 31 cvs. with known reaction to SBCMV were as expected from previous trials.

None of the cvs. remained symptomless, nor devoid of SBCMV. However, 25 entries (Saragolla, Neodur, AC Morse, Galadur, Hercules, Ben, Renville, AC Avonlea, Plaza, Duilio, Bravadur, Duraking, Nefer, Vic, Don Pedro, Lakota, Colorado, Reva, Anton, Plenty, Ionio, Goldur, AC Melita, Korifla, WB Turbo) showed two-year mean ELISA values lower than 0.100 as well as mild symptoms, and may thus be safely recommended to breeders and farmers in Italy. Whether or not these cvs. are resistant to SBCMV and / or SBWMV elsewhere in Europe and on other continents remains to be established. Interestingly, at least nine of these 25 cvs. and various others with relatively low ELISA values, were derived from "Edmore" (a cv. with a two-year mean ELISA value of 0.112), suggesting that the latter carries a major gene for resistance to SBCMV.

Most of the cvs. assayed, were susceptible to SBCMV, particularly Duriac, Messapia, Waha, Valnova, Valbelice, Ofanto, Heider, Excalibur, Tacna, Varano, Fortore, Karel, Agridur,

Produra, Jabato, Ciccio, Valforte, Extradur, Arcobaleno, Roqueño, Bronte, Grazia, and Primadur (all with a two-year mean ELISA value higher than 1,500). Due to their extreme reaction to SBCMV, these cultivars - as well as those cited above for SBCMV resistance - appear of interest for investigating the existence of pathogenic differences between and within SBWMV and SBCMV; indeed, due to their diverse adaptability and origin, a number of these cvs. can be grown and evaluated in regard to resistance to these viruses in a relatively wide range of environments.

References

- Canova, A., (1966). Researches on the virus diseases of grasses. II. Transmission of *Wheat soil-borne mosaic*. *Phytopath. Medit.* **5**, 53-58.
- Canova, A, and Quaglia, A. (1960). The *Soilborne wheat mosaic*. *Inf. Fitopatol* **10**: (10), 206-208
- Clover, G., Wright D., and Henry, C. (1999). Occurrence of *Soil-borne wheat mosaic virus* (SBWMV) in the United Kingdom. In: Proc. 4th Symp. Intern. Working Group on Plant Viruses with Fungal Vectors (J.L. Sherwood, C.M. Rush ed.), pp. 105-108.
- Estes, A.P., and Brakke, M.K. (1966). Correlation of *Polymyxa graminis* with transmission of *Soil-borne wheat mosaic virus*. *Virology* **28**, 772-774.
- Koenig R., and Huth, W. (2003). Natural infection of wheat by the type strain of *Soil-borne wheat mosaic virus* in a field in Southern Germany. *European J. Plant Pathology* **109**, 191-193.
- Maccaferri, M., Sanguineti, M.C., Noli, E., and Tuberosa, R. (2005). Population structure and long-range linkage disequilibrium in a durum wheat elite collection. *Mol. Breed.* **15**, 271–289.
- McKinney, H.H. (1923). Investigations of the rosette disease of wheat and its control. *J. Agr. Res.* **23**, 771-800.
- Mayo, M.A., Maniloff, J., Desselberger, U., and Bal, L.A. (2005). Virus taxonomy: “VIIIth Report of the International Committee on Taxonomy of Viruses” (C.M. Fauquet ed.), Academic Press, 1162 pp.
- Rubies-Autonell, C., Vallega, V., and Ratti, C. (2003). Reactions to SBWMV of cultivars of common wheat in northern Italy during 1996-97. *Z PflKrankh. PflSchutz.* **110**, 332-336.
- Shirako, Y., Suzuki, N., and French, R.C. (2000). Similarity and divergence among viruses in the genus *Furovirus*. *Virology.*, **270**, 201-207.
- Vallega, V., and Rubies-Autonell, C. (1985). Reactions of Italian *Triticum durum* cultivars to *Soil-borne wheat mosaic*. *Plant Dis.* **69**, 64-66.
- Vallega, V., and Rubies-Autonell, C. (1989). Further investigations on the presence of the *Soilborne wheat mosaic* in Italy. *Inf. Fitopat.* **39**, 57-58.
- Vallega, V., Rubies-Autonell, C., Turina, M., Ratti, C., and Contoli, S. (1999). Reactions to SBWMV of durum wheat cultivars grown in northern Italy during 1995-96. *Z PflKrankh. PflSchut.* **106**, 284-290.
- Vallega, V., Rubies-Autonell, C., and Ratti, C. (2003). Reaction of durum wheat cultivars to mixed SBWMV and WSSMV infection in central Italy” – *Phytopath. Medit.* **42**, 177-182.
- Vallega, V., Rubies Autonell, C., Ratti, C., Bianchi, L. (2004). Comportamento di cultivar di frumento duro e tenero rispetto al virus del mosaico comune del frumento (SBWMV): risultati di sei anni di prove “. Atti Giornate Fitopatologiche, Pescara, Italy, Vol. 2, 385-392.
- Wiese, M.V. (1987). Compendium of Wheat Diseases. 2nd edition, The American Phytopathological Society, St. Paul, MN, USA, 106 pp.
- Yang, J., Chen, J., Cheng, Y., and Adams, M.J. (2001) Sequence analysis of a *Soil-borne wheat mosaic virus* isolate from Italy shows that it is the same virus as *European wheat mosaic virus* and *Soil-borne rye mosaic virus*. *Science in China* **44**, 216-224.

IDENTIFICATION OF GENES DIFFERENTIALLY EXPRESSED IN SUGAR BEET ROOTS IN RESPONSE TO CHALLENGE BY *POLYMYXA GRAMINIS*

Graham R.D. McGrann, Lydia D. Martin, Michael J.C. Asher, Michael J. Adams¹ Effie S. Mutasa-Göttgens

Sugar Beet Research Division, Rothamsted Research, Brooms Barn Research Station, Higham, Bury St Edmunds, Suffolk, IP28 6NP, U.K.

¹Wheat Pathogenesis Programme, Plant-Pathogen Interactions Division, Rothamsted Research, Harpenden, Herts, AL5 2JQ, U.K.

Summary

Representational difference analysis (RDA) was used to identify expressed sequence tags (ESTs) differentially expressed in sugar beet roots in response to challenge by the 'non-host' parasite *Polymyxa graminis*. Sequence analysis using BLASTX against the GenBank sequence database of the RDA ESTs identified 43 unigene sequences of which 27 were homologous to plant genes, including 14 with roles in defence, and 16 sequences had unknown functions. PCR analysis confirmed that all of the uni-gene sequences were derived from sugar beet except EST BvNH1E4 which was specific to *P. graminis*. Semi-quantitative RT-PCR analysis of six of the ESTs (three with putative functions implicated in defence and three with no matches to the GenBank database) demonstrated up-regulation during the first hour in response to the non-host parasite. Results from these experiments, including details of *in silico* analysis of the ESTs of unknown function, are discussed.

Introduction

Polymyxa graminis and *Polymyxa betae* are important vectors of plant viruses infecting members of the Gramineae and Chenopodiaceae, respectively (Kanyuka *et al.*, 2003; Rush, 2003). Elite commercial cultivars carrying genes that confer resistance (either immunity or partial) to the viruses are available but the resistance has been shown to become eroded with time (Lui *et al.*, 2005; Kanyuka *et al.*, 2003). An alternative strategy to control these viral diseases would be to prevent transmission by their *Polymyxa* vectors. As sugar beet does not permit the development of *P. graminis* it exhibits a form of 'non-host' resistance to this organism. Non-host resistance is where an entire plant species or family is resistant to a specific parasite or pathogen (Heath, 2000) and it is considered to be highly durable.

We have used a PCR-based subtractive hybridisation technique, representational difference analysis (RDA), to identify expressed sequence tags (ESTs) enriched for genes that are differentially expressed in sugar beet roots when challenged by the non-host parasite *P. graminis*.

Materials and Methods

Sugar beet, *Beta vulgaris* cv Saxon and barley, *Hordeum vulgare* cv Fanfare were used throughout these experiments. Ten day old sugar beet seedlings or barley seeds three days post germination were immersed in a zoospore suspension of 10^6 spores mL⁻¹ of either *P. betae* or *P. graminis* to give both non-host and host challenged samples; control unchallenged plants were obtained by immersion in a 0.5% w/v bovine serum

albumin solution. Twenty plants from each interaction were removed every fifteen minutes during the first hour, and then at hourly intervals up to seven hours post-challenge, and the root excised and frozen in liquid nitrogen. Ten root samples from each time point were pooled to generate separate host, non-host and unchallenged root samples for both sugar beet and barley covering the seven hour challenge period. The seven hour duration of the challenge with *Polymyxa* zoospores was chosen to cover the optimal period of zoospore motility, attachment and penetration as previously observed in *Polymyxa*-host interactions (Adams and Swaby, 1988; Barr *et al.*, 1995).

Frozen root material was ground into a fine powder in liquid nitrogen. Total RNA was extracted using TRIzol (Invitrogen, Paisley, U.K.) and poly(A)+ RNA subsequently isolated using Oligotex mRNA kit (Qiagen, Hilden, Germany). cDNA synthesis and RDA was done following the procedure of Chang *et al.* (1998) for the sugar beet-*P. graminis* (non-host) interaction only, using the pooled RNA samples.

RDA products from the second round were cloned and the resultant plasmids used to produce an arrayed library as described (Kingsnorth *et al.*, 2003). Plasmid minipreps were prepared for custom sequencing (DBS Genomic, Durham, U.K.) using standard protocols (Sambrook *et al.*, 1989). To identify proteins encoded by the sequenced RDA-ESTs, GenBank database searches were carried out using the BLASTX searching tool (Altschul *et al.*, 1997) via the NCBI web site. RDA EST sequences that had no match in the GenBank database or matched proteins of unknown function were screened against the TIGR sugar beet gene index EST database (TIGR BvGI) using BLASTN.

Sequences of the sugar beet ESTs with the closest match were retrieved and screened against the translated GenBank database entries (using tBLASTX). All RDA gene fragments which failed to find a match in the sugar beet TIGR BvGI database or with high scores and e-values below $1e^{-10}$ were further screened against the TIGR Barley gene index EST database (TIGR HvGI). Sequences of matching barley ESTs were then screened against the GenBank database as above. For protein sequence comparison, multiple alignments were produced using ClustalW version 1.8 (Thompson *et al.*, 1994), and displayed in GeneDoc version 2.6 (Nicholas and Nicholas 1997).

The origin of the ESTs (plant or *Polymyxa*) was confirmed by end-point PCR using sequence specific primers. The expression patterns during the first hour of challenge (sugar beet-*Polymyxa* susceptible host, non-host and unchallenged) of six ESTs (three homologous to genes implicated in plant defence and three with no significant matches on the GenBank database) were deduced using semiquantitative RT-PCR. Primers designed to a consensus sequence of the eukaryotic 18S rDNA gene (L- 5'TGA CGG AGA ATT AGG GTT CG3' and R- 5'CCT CCA ATG GAT CCT CGT TA3') were used to demonstrate equal cDNA levels.

Results and Discussion

RDA was successfully used to isolate in the region of 600 clones. Approximately 25% of these clones were sequenced and screened for homology using the BLASTX tool on the GenBank database, with significant matches assigned when the e-value was $<1e^{-5}$. Ninety two percent of the sequencing reactions produced sequences that could be screened on the database and, from this, 43 uni-gene sequences were identified. Twenty seven of these unigenes showed homology to plant genes with a known function, five matched sequences for which the biological function remains unknown and the remaining 11 had no significant match on the GenBank database. Of the 27 unigenes with homology to known plant genes, 14 had functions previously implicated in plant defence (Table 1). These included genes involved in the production of secondary metabolites and other antimicrobial compounds, detoxification enzymes, as well as

genes involved in pathogen perception and signalling. PCR analysis demonstrated that all of the uni-gene sequences were of sugar beet origin except one (*BvNH1E4*) which was *P. graminis* specific.

Semi-quantitative RT-PCR analysis of a putative protein serine/threonine kinase (signalling), 3-deoxy-D-arabino-heptulosonate (DAHPS), glutamate dehydrogenase (both secondary metabolism) and three ESTs with no significant homology (*BvNH3A1*, 3A4 and 3B10) showed that all except *BvNH3B11* were significantly up-regulated in the

Table 1: Details of the unisequences from the sugar beet non-host RDA library similar to sequences previously implicated in plant defence as identified by BLASTX searching of the GenBank database

cDNA code	Size (bp)	Proteins encoded by the homologous plant genes	E value
Metabolism			
<i>BvNH2A12</i>	464	(CAA75092) 3-deoxy-D-arabino-heptulosonate 7-phosphate synthase – <i>Morinda citrifolia</i>	5e ⁻⁶⁷
<i>BvNH3B11</i>	199	(AAx20154) Glutamate dehydrogenase - <i>Lupinus luteus</i>	6e ⁻²⁵
<i>BvNH3F10</i>	232	(AAR06913) UDP-glucosyltransferase 85A8 – <i>Stevia rebaudiana</i>	8e ⁻²⁸
<i>BvNH3H8</i>	377	(AAx20154) Glutamate dehydrogenase - <i>Lupinus luteus</i>	9e ⁻¹⁴
Protein synthesis and processing			
<i>BvNH1G6</i>	444	(NP_177807) Eukaryotic translation initiation factor/eIF2 - <i>Arabidopsis thaliana</i>	1e ⁻³⁹
<i>BvNH3A5</i>	322	(CA80334) Ubiquitin extension protein - <i>Lupinus albus</i>	7e ⁻³⁹
Defence/stress/oxidative burst			
<i>BvNH1D6</i>	165	(BAC42324) Putative cyclophilin like protein ROC14 - <i>Arabidopsis thaliana</i>	1e ⁻²⁰
<i>BvNH2D5</i>	189	(AAP80800) Class VII Chitinase precursor – <i>Gossypium hirsutum</i>	2e ⁻⁸
<i>BvNH3G7</i>	124	(CAA46863) Thiolprotease - <i>Pisum sativum</i>	2e ⁻⁹
Cell wall structure and development			
<i>BvNH3F3</i>	149	(NP_176723) Glycine rich protein – <i>Arabidopsis thaliana</i>	8e ⁻²⁰
Signal transduction			
<i>BvNH1C7</i>	353	(AAR11300) Lectin-like receptor kinase 7;3 - <i>Medicago truncatula</i>	3e ⁻³⁹
<i>BvNH1E5</i>	344	(BAA06538) Protein Serine/threonine kinase - <i>Nicotiana tabacum</i>	2e ⁻³⁹
<i>BvNH2D7</i>	151	(AAQ87008) BTB and TAZ domain protein 5 - <i>Arabidopsis thaliana</i>	8e ⁻⁹
<i>BvNH3G1</i>	285	(CAA48538) Serine /threonine protein kinase - <i>Arabidopsis thaliana</i>	1e ⁻¹⁷

non-host response during the first hour of the challenge, compared to the unchallenged and host (susceptible) interactions.

Further bioinformatics analyses of the ESTs with either unknown functions or with no significant homology from the GenBank screen identified three sequences of particular interest in the TIGR BvGI and HvGI databases. *BvNH3A1* and *BvNH3G3* both had good matches to ESTs in both databases. However, the ESTs similar to *BvNH3A1* in both databases, when screened back against GenBank, were closely matched with a mouse sequence suggesting that this EST may have a novel function in plants. *BvNH3G3*

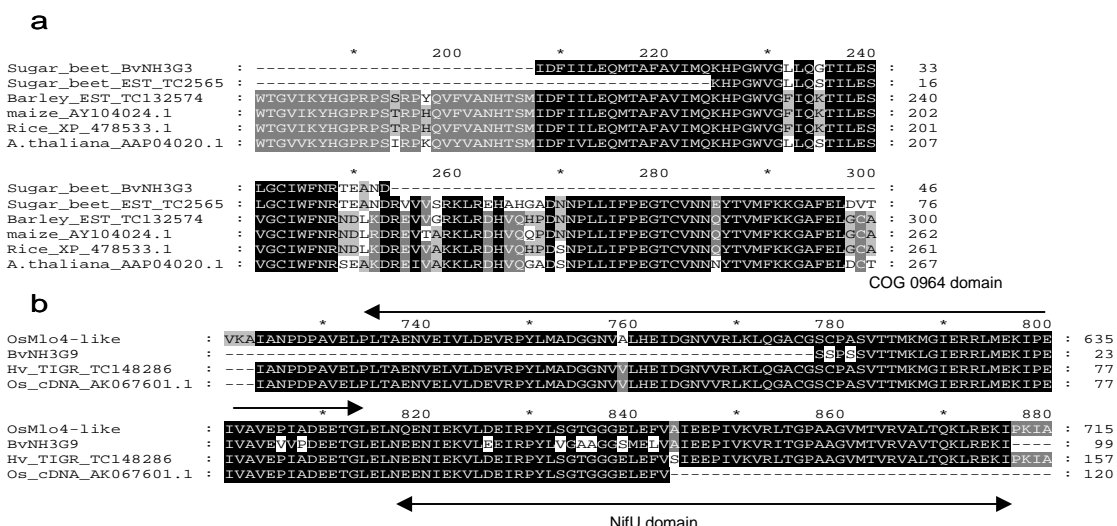

Fig. 2 Protein sequences alignments for *BvNH3G3* (a) and *BvNH3G9* (b). Identical amino acids are shaded in black, similar amino acids in grey.

was matched to an *Arabidopsis thaliana* phospholipid/glycerol acyltransferase family protein and a putative phospholipid/glycerol acyltransferase mRNA from rice at the nucleic acid level using the tBLASTX tool. Alignments of the translated TIGR BvGI sugar beet EST, TIGR HvGI barley EST, GenBank maize, rice, *A. thaliana* and our own RDA BvNH3G3 revealed a high level of homology, indicating that they probably all encoded proteins from the phospholipid/glycerol acyltransferase family (Fig. 2a). BvNH3G9 had no matches in the TIGR BvGI sugar beet EST database, but had strong homology with the TIGR barley EST TC148286 which was closely matched to the translated sequence of an uncharacterised rice cDNA clone and with a predicted transmembrane MLO4-like-NifU/COG0694 domain fusion protein in the rice BAC AC135794. Alignment of the translated sugar beet RDA clone BvNH3G9 and the TIGR HvGI barley EST, revealed a close alignment with the rice cDNA and the C-terminus of the rice MLO4-like BAC sequence, a region which contains the NifU domain (a carboxy-terminal domain of unknown function, first discovered in and common to the NifU protein from nitrogen-fixing bacteria and rhodobacterial species) and the COG0694 domain. The latter is associated with thioredoxin-like proteins that are involved in post-translational modification, protein turnover and as chaperones (Marchler-Bauer *et al.*, 2005) (Fig. 2b).

These data indicate that the non-host response of sugar beet to *P. graminis* is an active response that may involve a signal transduction cascade possibly mediated by receptors. This in turn could initiate downstream protein kinase (e.g. BvNH1E5) cascades that result in the increased production of plant phenolic compounds. General up-regulation of secondary metabolism pathways, as possibly represented by our observed DAHPS up-regulation (BvNH2A12), could then lead to factors that prevent *P. graminis* penetration by cell wall strengthening and possibly also direct antimicrobial effects, resulting in the non-host resistant response.

We thank Crawford Kingsnorth, Daphne Mothersole and Guillaume Erard for technical assistance. This work was funded from the Biotechnology and Biological Sciences Research Council CSG grant to Rothamsted Research. Broom's Barn Research Station is a division of Rothamsted Research.

References

- Adams, M. J., and A. G. Swaby. 1988. Factors affecting the production and motility of zoospores of *Polymyxa graminis* and their transmission of barley yellow mosaic virus (BaYMV). *Annals of Applied Biology* 112:69-78.
- Altschul, S. F. *et al.* 1997. Gapped BLAST and PSI-BLAST: a new generation of protein database search programs. *Nucleic Acids Research* 25:3389-3402.
- Barr, K. J., M. J. C. Asher, and B. G. Lewis. 1995. Resistance to *Polymyxa-Betae* in Wild Beta-Species. *Plant Pathology* 44:301-307.
- Chang, D. D. *et al.* 1998. Characterization of transformation related genes in oral cancer cells. *Oncogene* 16:1921-1930.
- Heath, M. C. 2000. Nonhost resistance and nonspecific plant defenses. *Current Opinion in Plant Biology* 3:315-319.
- Kanyuka, K., E. Ward, and M. J. Adams. 2003. *Polymyxa graminis* and the cereal viruses it transmits: a research challenge. *Molecular Plant Pathology* 4:393-406.
- Kingsnorth, C. S., E. S. Mutasa-Gottgens, and M. J. C. Asher. 2003. Isolation and characterization of genes induced during non-host resistance to *Polymyxa* spp. *Proceedings of the Fifth Symposium of the International Working Group on Plant Viruses with Fungal Vectors 2002*. Zurich, Switzerland, 76-79.

- Lui, H-Y., J. L. Sears, and R. T. Lewellen. 2005. Occurrence of resistance-breaking *Beet necrotic yellow vein virus* of sugar beet. *Plant Disease* 89:464-468.
- Marchler-Bauer, A. *et al.* 2005. CDD: a conserved domain database for protein classification. *Nucleic Acids Research* 33:D192-D196.
- Nicholas, K. B. and Nicholas, H. B. 1997. Genedoc: a tool for editing and annotating multiple sequence alignments.
- Rush, C. M. 2003. Ecology and epidemiology of Benyviruses and plasmodiophorid vectors. *Annual Review of Phytopathology* 41:567-592.
- Sambrook, J., E.F. Fritsch, and T. Maniatis. 1989. *Molecular Cloning*. Second ed: Cold Spring Harbour Laboratory Press.
- Thompson, J. D.*et al.* 1994. ClustalW - improving the sensitivity of progressive multiple sequence alignment through sequence weighting, position-specific gap penalties and weight matrix choice. *Nucleic Acids Research* 22:4673-4680.

REACTION OF CULTIVARS OF TRITICUM AESTIVUM L. TO WHEAT SPINDLE STREAK MOSAIC VIRUS AND TO SOILBORNE CEREAL MOSAIC VIRUS

C. Rubies Autonell¹, V. Vallega² and C. Ratti¹,

¹Department of Agroenvironmental Science and Technology, University of Bologna, Viale Fanin 44, 40127 Bologna, Italy

²C.R.A. Experimental Institute for Cereal Research, Via Cassia 176, 00191 Rome, Italy.

Summary

Thirty wheat cultivars presently marketed in Italy were grown near Rome in a field with natural inoculum sources of *Wheat spindle streak mosaic virus* and *Soilborne cereal mosaic virus* and evaluated for resistance to both pathogens using DAS (Double Antibody Sandwich) ELISA. Cultivars Nearco, Savio, Buon Pastor, Salvia, Sagittario, Collerosso, Delfino and Mieti proved susceptible to WSSMV, whereas cultivars Cranklin, Artico and Levis showed low ELISA values. The latter presently appear as the best choice for WSSMV-infested soils in Italy. Two of these cultivars, namely Artico and Levis, are known to be highly resistant also to SBCMV. ELISA value rankings for SBCMV among the thirty cultivars were analogous to those recorded in northern Italy.

Introduction

In Italy, *Wheat spindle streak mosaic virus* (WSSMV) and *Soilborne cereal mosaic virus* (SBCMV), both vectored by *Polymyxa graminis* Ledingham (Canova 1966; Estes and Brakke 1966), were identified for the first time in 1987 (Rubies-Autonell and Vallega) and 1960 (Canova and Quaglia 1960), respectively. SBCMV is widespread, particularly in the northern and central regions (Vallega and Rubies-Autonell 1989), whereas WSSMV has been thus far identified in only about 20 farms generally in mixed infection with SBCMV (Rubies-Autonell *et al.* 2003). The only economically viable means of avoiding the serious losses caused by these two pathogens is that of growing resistant cultivars (Wiese 1987, Vallega *et al.* 2003). The reaction to SBCMV of most of the cultivars of common wheat (*Triticum aestivum* L.) grown in Italy has been investigated extensively (Rubies-Autonell *et al.* 2003; Vallega *et al.* 2004), but their reaction to WSSMV is unknown.

Materials and Methods

Thirty cultivars of common wheat (*Triticum aestivum* L.) and "Grazia", a cultivar of durum wheat (*T. durum* Desf.) known for its susceptibility to both viruses, were grown near Rome in a field with natural inoculum sources of WSSMV and SBCMV. All entries were sown October 9 (2003) in 10 sq. m. solid-seeded plots, distributed in the field according to a randomized block design with three replicates. Virus concentration was determined on extracts from leaves collected March 16, 2003, using DAS (*Double Antibody Sandwich*) ELISA according to the procedure of Clark and Adams (1977), modified as follows: sap extracted from leaves was diluted 1:6 in a phosphate saline buffer (pH 7.2) containing 0.05% tween-20, 2% polyvinyl-pyrrolidone (MW 24,000), 0.2% powdered chicken-albumin and 0.5 mol l⁻¹ urea. Extracts were from a bulk of the apical half of the second and third youngest leaves of 10 randomly chosen plants / plot.

Results and Discussion

All the cultivars assayed became infected with WSSMV (Table 1). Cultivars Collerosso, Sagittario, Salvia, Buon Pastor, Savio, Nearco, and especially Mieti and Delfino (with ELISA values equal or superior to that of the durum wheat control), proved most susceptible to this virus. Only extracts from cultivars Cranklin, Artico and Levis had low ELISA values (< 0.100). Although further trials are needed to verify the resistance of the latter cultivars to WSSMV, at present these seem the best choice for WSSMV-infested soils in Italy, especially if one considers that cultivars Artico and Levis, are highly resistant also to SBCMV (Rubies-Autonell *et al.* 2003; Vallega *et al.* 2004). ELISA value rankings for SBCMV among the thirty cultivars tested were analogous to those recorded in northern Italy (Rubies-Autonell *et al.* 2003; Vallega *et al.* 2004); various cultivars (Agadir, Blasco, Cranklin, Guarnì, Mieti and Salvia), however, showed unexpectedly low absorbances, possibly because of a lesser disease pressure.

Table 1 - ELISA values ^a for thirty cultivars of common wheat (<i>Triticum aestivum</i> L.) to <i>Wheat spindle streak mosaic virus</i> (WSSMV) and <i>Soil-borne cereal mosaic virus</i> (SBCMV) grown in a field near Rome, Italy, in 2004.					
Cultivar	SBCMV	WSSMV	Cultivar	SBCMV	WSSMV
Agadir	0.009 c ^b	0.150 bc	Levis	0.036 c	0.072 bc
Alcione	0.006 c	0.371 ac	Mieti	0.019 c	0.619 a
Artico	0.047 c	0.063 c	Nearco	1.762 ab	0.401 ac
Bilancia	0.440 c	0.201 ac	Palesio	1.121 ac	0.327 ac
Bisquit	0.008 c	0.233 ac	Positano	1,755 ab	0.242 ac
Blasco	0,054 c	0.288 ac	Provinciale	0.237 c	0.218 ac
Bolero	0.799 bc	0.371 ac	Quality	0.010 c	0.273 ac
Buon Pastor	1.753 ab	0.422 ac	Ravenna	0.942 bc	0.269 ac
Centro	0.081 c	0.319 ac	Sagittario	0.781 bc	0.457 ac
Collerosso	2.066 a	0.492 ac	Salvia	0.101 c	0.433 ac
Craklin	0.054 c	0.048 c	Savio	0.917 bc	0.403 ac
Delfino	0.650 c	0.518 ab	Serio	0.065 c	0.202 ac
Eureka	0.021 c	0.383 ac	Valoris	0.286 c	0.397 ac
Guadalupe	0.852 bc	0.234 ac	VTA 7109	0.574 c	0.252 ac
Guarnì	0.013 c	0.359 ac	Mean	0.532	0.306
Isengrain	0.507 c	0.172 ac	Grazia***	2.307	0.518

^aELISA performed on extracts from leaves collected March 16, 2004);
^bWithin columns, means followed by the same letters are not significantly different (P=0.05) according to Duncan's multiple range test.

References

Canova, A., and Quaglia A. (1960). The *Soilborne wheat mosaic*. *Inf. Fitopatol.* **10**, 206-208.

- Canova, A., (1966). Researches on the virus diseases of grasses. II. Transmission of *Wheat soil-borne mosaic*. *Phytopath. Medit.* **5**, 53-58.
- Clover, G., Wright D., and Henry, C. (1999). Occurrence of *Soil-borne wheat mosaic virus* (SBWMV) in the United Kingdom. *In: Proc. 4th Symp. Intern. Working Group on Plant Viruses with Fungal Vectors* (J.L. Sherwood, C.M. Rush ed.), 105-108.
- Estes, A.P., and Brakke, M.K. (1966). Correlation of *Polymyxa graminis* with transmission of *Soil-borne wheat mosaic virus*. *Virology* **28**, 772-774.
- Koenig R., and Huth, W. (2003). Natural infection of wheat by the type strain of *Soil-borne wheat mosaic virus* in a field in Southern Germany. *European J. Plant Pathology* **109**, 191-193.
- McKinney, H.H. (1923). Investigations of the rosette disease of wheat and its control. *J. Agr. Res.* **23**,: 771-800.
- Mayo, M.A., Maniloff, J., Desselberger, U., and Bal, L.A. (2005). Virus taxonomy: "VIIIth Report of the International Committee on Taxonomy of Viruses" (C.M. Fauquet ed.), Academic Press, 1162 pp.
- Rubies-Autonell, C., and Vallega V. (1987). Observations on a mixed *Soil-borne wheat mosaic virus* and *Wheat spindle streak mosaic virus* infection in durum wheat *Triticum durum* Desf. *J. Phytopathology* **119**, 111-121.
- Rubies-Autonell, C., Vallega, V., and Ratti, C. (2003). Reactions to SBWMV of cultivars of common wheat (*Triticum aestivum* L.) in northern Italy during 1996-97. *Z PflKrankh. PflSchutz.* **110**, 332-336.
- Rubies-Autonell, C., Ratti, C., Fornara, M., and Vallega, V. (2003). Virus, le varietà resistenti. *Terra e Vita* **54**, (36) 58-61 (in Italian).
- Shirako, Y., Suzuki, N., and French, R.C. (2000). Similarity and divergence among viruses in the genus *Furovirus*. *Virology.*, **270**, 201-207.
- Vallega, V., and Rubies-Autonell, C. (1985). Reactions of Italian *Triticum durum* cultivars to *Soil-borne wheat mosaic*. *Plant Dis.* **69**, 64-66.
- Vallega, V., and Rubies-Autonell, C. (1989). Further investigations on the presence of the *Soilborne wheat mosaic* in Italy. *Inf. Fitopat.* **39**, 57-58.
- Vallega V., C. Rubies-Autonell, C. Ratti and M. Turina (1997). Reactions of 36 common wheat cultivars to *Soilborne wheat mosaic virus* during 1995-1996. *In: Proceedings of the 10th Congress of the Mediterranean Phytopathological Union.* (Soc. Française de Phytopatologie, ed.), Montpellier, France, 627-631.
- Vallega, V., Rubies-Autonell, C., Turina, M., Ratti, C., and Contoli, S. (1999). Reactions to SBWMV of durum wheat cultivars grown in northern Italy during 1995-96. *Z PflKrankh. PflSchut.* **106**, 284-290.
- Vallega, V., Rubies-Autonell, C., and Ratti, C. (2003). Reaction of durum wheat cultivars to mixed SBWMV and WSSMV infection in central Italy". *Phytopath. Medit.* **42**, 177-182.
- Vallega, V., Rubies Autonell, C., Ratti, C., Bianchi, L. (2004). Comportamento di cultivar di frumento duro e tenero rispetto al virus del mosaico comune del frumento (SBWMV): risultati di sei anni di prove ". *Atti Giornate Fitopatologiche, Pescara, Italy, Vol. 2*, 385-392.
- Wiese, M.V. (1987). Compendium of Wheat Diseases. 2nd edition, The American Phytopathological Society, St. Paul, MN, USA, 106 pp.
- Yang, J., Chen, J., Cheng, Y., and Adams, M.J. (2001) Sequence analysis of a *Soil-borne wheat mosaic virus* isolate from Italy shows that it is the same virus as *European wheat mosaic virus* and *Soil-borne rye mosaic virus*. *Science in China* **44**, 216-224.

Selection of durum and common wheat accessions for resistance to furoviruses under controlled environmental conditions

Ute Kastirr¹, Edgar Müller², Peter Römer², Ralf Schachschneider³ and Thilo Hammann⁴

¹Federal Centre for Breeding Research on Cultivated Plants, Institute of Resistance Research and Pathogen Diagnostics, D-06449 Aschersleben, Germany

²Südwestsaat GbR, D-76427 Rastatt, Germany

³Nordsaat Saatzucht GmbH Langenstein, D-38895 Böhnshausen, Germany

⁴SW Seed Hadmersleben GmbH, D-39398 Hadmersleben, Germany

Summary

A method for resistance selection of cereals to furoviruses was established under controlled environmental conditions and compared with screening tests under field conditions. This test allows a clear differentiation of resistance levels between wheat genotypes, reproducible and independent from plant growth stage. The results obtained under conditions in growth chambers were confirmed by those obtained in parallel field experiments. The virus infection in roots and leaves of resistant wheat varieties was investigated in climatic chambers with inoculation by infested soils. The results of these experiments suggest that SBCMV was fungus transmitted and multiplied in most of the plant roots of resistant cultivars. The virus was transmitted from infected roots to the leaves in 25% to 37% of single plants in resistant wheat varieties.

Introduction

The furoviruses are widely distributed in European countries (France, Italy, Germany, UK, Denmark, Poland) in durum wheat, bread wheat, triticale and rye. These pathogens cause serious cereal diseases in infested locations. Yield losses up to 60% have been recorded in virus infested durum wheat fields in Italy (Vallega *et al.*, 2003). The grain yield of susceptible UK winter wheat cultivars was reduced up to 50% (Clover *et al.*, 2001). In Germany the furovirus *Soilborne cereal mosaic virus* (SBCMV) and the bymovirus *Wheat spindle streak mosaic virus* (WSSMV) occur in different federal states and induce yield losses up to 70%, especially in rye and triticale growing areas (Huth and Lesemann, 1996). High growth depressions in winter wheat were observed in a field infested by *Soilborne wheat mosaic virus* (SBWMV) in South Germany (Koenig and Huth, 2003). The selection of resistant cultivars is the only effective method to control these virus diseases. In most countries with soilborne virus infected regions, extensive programs for selection of virus resistance were started with the aim of breeding for resistant cultivars. Screening for resistance of cereals to soilborne viruses was initiated under field conditions in different environments. Specific investigation of virus transmission by the fungal vector *Polymyxa graminis* Ledh., analyses of resistance mechanisms, and comparison of several pathogen populations was carried out under growth chamber conditions (Hariri *et al.*, 1987; Armitage *et al.*, 1990; Driskel *et al.*, 2002; Kastirr *et al.*, 2002; Kanyuka *et al.*, 2004). The aim of this study was to find an effective method for pre-screening of wheat genotypes for virus resistance under controlled and reproducible conditions independent of plant growth stage.

Materials and Methods

Different common wheat (*Triticum aestivum*) cultivars (36) and wild forms (60) and cultivars (10), gene bank accessions (70) and breeding lines (20) of durum wheat (*Triticum durum*) supplied by different German seed breeding companies were tested under controlled environmental conditions in infested soils. The soil samples used for resistance tests in growth chambers were infested with either SBCMV from Eickeloh, or SBWMV from Heddesheim-H. Gene bank accessions were provided by the Germplasm Collection of IPK Gatersleben, Germany. 11 Italian durum wheat and 12 common wheat varieties provided by Dr. C. Rubies-Autonell and Dr. V. Vallega were included in these experiments. On the one hand the wheat entries were cultivated with 16 single plants per genotype under growth chambers conditions of 17 °C and 16 hours light (20.000 lux) for 10 weeks. For comparison with the experiments under controlled conditions. the entries were grown in randomized plots under natural field conditions (4 repetitions). The field experiments performed in infested locations of Germany (Gödnitz-Gö, Walternienburg-WN and -PW) and of the Experimental Station in Bologna-Bo overseen by Dr. Rubies-Autonell. The field infections were observed in 10 single plants per genotype and repetition at 3 times from February to April. Virus detection was accomplished by DAS/TAS-ELISA in leaves and by tissue print immune assay (TPIA) in plant roots.

Results and discussion

The selection for resistance to furoviruses under controlled environmental conditions allowed a clear differentiation of resistance levels between wheat accessions. The durum cultivars *Nefer*, *Colorado*, *Neodur* characterized as resistant forms showed a low virus infection under controlled conditions (Table 1). In comparison, field resistance from 3 locations was observed in *Nefer* only. *Colorado* and *Neodur* were highly infected by the pathogen population at Gödnitz. The tested susceptible varieties were strongly infected by German and Italian virus isolates without distinction. The results obtained under conditions in growth chambers were confirmed by those obtained from parallel field experiments, considering differences between the virulence of several virus isolates. Gene bank accessions of durum wheat with resistance to both furoviruses, reacted similarly in field and climatic chamber conditions (Tabel 2). Resistant common wheat cultivars were investigated for virus transmission by *Polymyxa graminis* from naturally infested soils, under controlled conditions. All tested cultivars showed root infections with SBCMV (Table 3). Virus transmission from infected roots of these cultivars to the leaves occurred in 12% to 37% of the plants, under growth chamber conditions, and in about 4% of field plants. The expected translocation resistance in these cultivars could not be confirmed.

Acknowledgements

Funding of this work by the InnoPlanta Plant Bioengineering Initiatives of BMFB of Germany (FK 03i0607, FK 03i0623) is acknowledged. Many thanks are due to Dr. Rubies-Autonell for the screening of German durum wheat cultivars in the infested location near Bologna and Dr. Vallega for discussion about the results of grown chamber experiments. We thank the Germplasm collection of IPK Gatersleben for providing us with seed material and the German breeder companies Nordsaat Saat-zucht, Saat-zucht Hadmersleben and Saat-zucht Späth for cooperation in breeding methods.

Table 1: Comparison of resistance reactions of durum wheat cultivars under grown chamber and field conditions

<i>Triticum durum</i>	Virus detection by DAS-ELISA (E405)				
	Growth chamber		SBCMV fields infested		
	Infested soils from				
Cultivars	H (SBWMV)	Ei (SBCMV)	WN	Gö	Bo
<i>Nefer</i>	0.13	0.24	0.22	0.04	0.05
<i>Colorado</i>	0.32	0.23	0.15	0.58	0.11
<i>Neodur</i>	0.16	0.31		0.98	0.05
<i>Soldur</i>		0.15	0.36	0.34	0.14
<i>Ciccio</i>	0.57	1.08	2.56	0.77	1.57
<i>Cirillo</i>	0.63	1.10	1.24	1.66	1.52

Table 2: Resistance reaction of gene bank accessions of durum wheat comparison between conditions in growth chambers and in different infested fields

<i>Triticum durum</i>	Virus detection by DAS-ELISA (E405)				
	Growth chamber		SBCMV fields infested		
	Infested soils from				
Accessions	H (SBWMV)	Ei (SBCMV)	WN	PW	Gö
6976	1.35	0.79	0.60	0.03	0.11
6979	1.27	0.65	0.31	0.01	0.02
16459	0.25	0.10	0.16	0.01	0.02
16460	0.11	0.07	0.17	0.02	0.18
16463	0.05	0.20	0.08	0.01	0.08
26348	0.20	0.08	0.13	0.10	0.10
37233	1.71	1.11	0.52	0.03	0.13
37236	1.81	1.24	0.62	0.07	0.26

Table 3: Virus transmission in roots and leaves of resistant common wheat cultivars after inoculation by infested soils under controlled conditions

Wheat cultivar	Test method	SBCMV infection in roots (TPIA) and leaves (DAS-ELISA) of single plants																means		
		1	2	3	4	5	6	7	8	9	10	11	12	13	14	15	16	TPIA	ELISA	
<i>Charger</i>	TPIA	++	+	++	+		++	+	++	+	+	+	++	+	+++	+++	+++	1.7		
	DAS-ELISA	0.0	1.9	0.5	0.0	0.0	0.0	0.0	0.0	0.0	0.0	0.0	2.9	2.0	0.0	0.0	0.0		0.5	
<i>Tremie</i>	TPIA	++	++	+	+	+	+++	+	+++	+	++	++	+			+	++	1.5		
	DAS-ELISA	0.0	0.0	0.0	0.0	1.9	1.0	0.0	0.0	0.0	0.0	0.0	0.0	0.0		0.3	1.3		0.3	
<i>Caesar</i>	TPIA	+	++	+	++		+++	++	+	++	+	+		+	+++	+	-	1.4		
	DAS-ELISA	0.5	0.0	0.0	0.0		0.0	0.0	0.0	1.1	2.0	1.2		0.0	0.1	0.1	0.0		0.4	
<i>Cliff</i>	TPIA	+	+	++	+	++	++	++				+	-	-	-	-	+	+	1.0	
	DAS-ELISA	0.0	0.0	0.0	0.0	0.0	0.0	0.0	0.0			0.0	0.0	0.0	0.0	0.0	0.3	1.,1		0.1
<i>Cezanne</i>	TPIA	+	++	++		+++				++	+++	++						1.9		
	DAS-ELISA	0.4	1.2	1.,6	1.7	0.3	1.0	1.6	2.7	0.4	1.3	2.2	2.2	0.0	1.2	1.8	2.2		1.4	
<i>Herold</i>	TPIA	+++	+++	+++	+++	+	++	+++	++									2,5		
	DAS-ELISA	0.2	0,3	0.5	0.5	0.2	0.3	0.4	0.5	0.3	0.2	0.4	0.2	0.2	0.,7	1.1	1.2		0.5	
<i>Ephoros</i>	TPIA									++	++	+++	++	+	+++	+	+	1.9		
	DAS-ELISA	1.2	1.8	0.0	1.4	0.8	1.6	1.,5	0.0	1.0	1.4	1.2	1.3	1.8	2.3	1.8	1.9		1.3	

References

- Armitage C R, Hunger R M and Sherwood J L (1990). Relationship between development of hard red winter wheat and expression of resistance to Wheat soil-borne mosaic virus. *Plant Disease* **74**, 356-359.
- Clover G R G, Wright D, Henry C M (2001). Occurrence of *Soil-borne wheat mosaic virus* in the UK. In: *Proceedings of the Fourth Symposium of the International Working Group on Plant Viruses with Fungal Vectors, 1999*, eds J L Sherwood & C M Rush, pp. 105-108.
- Driskel B A, Hunger R M, Payton M E and Verchot-Lubicz J (2002). Response of hard red winter wheat to *Soil-borne wheat mosaic virus* using novel inoculation methods. *Phytopathology* **92**, 347-354.
- Hariri D, Courtillot M, Zaoui P and Lapierre H (1987). Multiplication of soilborne wheat mosaic virus (SBWMV) in wheat roots infected by a soil carrying SBWMV and wheat yellow mosaic virus (WYMV). *Agronomie* **7**, 789-796.
- Huth W and Lesemann D E (1996). Fungus-transmitted soil-borne viruses on rye in Germany. *J. Plant Disease and Protection* **103**, 120-124.
- Kanyuka K, Lovell D, Mitrofanova O P, Hammond-Kosack K and Adams M J (2004). A controlled environment test for resistance to Soil-borne cereal mosaic virus and its use to determine the mode of inheritance of the resistance in the UK wheat variety Cadenza, and to screen diverse *Triticum monococcum* genotypes for potential sources of improved disease resistance. *Plant Pathology* **53**, 154-160.
- Kastirr U, Rabenstein F and Kühne T (2002). Evaluierung von Roggen und Weizen auf Resistenz gegen das *Soil-borne cereal mosaic virus* (SBCMV) unter kontrollierten Bedingungen. *Votr. Pflanzenzüchtg.* **54**, 263-266.
- Koenig R. and Huth W. (2003). Natural infection of wheat by the type strain of *Soil-Borne Wheat Mosaic Virus* in a field in Southern Germany. *European Journal of Plant Pathology* **109**, 191-193.
- Vallega V, Rubies-Autonell C and Ratti C (2003). Reaction of durum wheat cultivars to mixed SBWMV and WSSMV infection in central Italy. *Phytopathol. Mediterr.* **42**, 177-182.

THE USE OF PCR METHODS FOR *POLYMYXA GRAMINIS* TO STUDY INTRASPECIFIC VARIATION, PHYLOGENY AND INOCULUM LEVELS

Elaine Ward, Juliet Motteram, Kostya Kanyuka and Michael J Adams

Wheat Pathogenesis Programme, Plant Pathogen Interactions Division, Rothamsted Research, Harpenden, Herts AL5 2JQ, UK
elaine.ward@bbsrc.ac.uk

Summary

The soil-dwelling organism *Polymyxa graminis* is an important vector of viruses particularly in cereals. The molecular characterization of PCR-amplified ribosomal DNA (rDNA) sequences has provided new insights into relationships among *Polymyxa* isolates and the plasmodiophorids. This approach has also helped to confirm that these organisms are not true Fungi and to clarify their relationships with other protist taxa. Although all isolates of *Polymyxa* (*P. betae* and *P. graminis*) appear to be morphologically identical, they can be distinguished into at least six different rDNA types (ribotypes). These ribotypes show variation in host range, ability to transmit viruses and other biological properties.

Although PCR-based methods for identification of *P. graminis* have been available for some time, until recently there was no simple method for its quantification. We have now developed a real-time quantitative PCR assay for *P. graminis* and used it to investigate inoculum levels in infected roots and soil. This is proving useful in investigation of host plant resistance to *P. graminis*.

Introduction

Polymyxa graminis, the vector of a range of plant viruses, is a eukaryotic obligate parasite of plant roots that belongs to a poorly studied taxonomic group informally called the plasmodiophorids (Kanyuka *et al.*, 2003). Within the genus *Polymyxa*, two species have been recognized largely on the basis of host range. *P. graminis* primarily multiplies in grass and cereal species whilst *P. betae* is a parasite of species in the family *Chenopodiaceae* and some related plants and is also a virus vector, e.g. of rhizomania disease in sugar beet. Within *Polymyxa graminis* several subgroups (ribotypes) can be distinguished using RFLPs and sequencing of nuclear ribosomal DNAs (rDNAs) (Ward & Adams, 1998; Morales *et al.*, 1999; Legrève *et al.*, 2002). Additional *Polymyxa* rDNA sequences were determined from samples from wheat, rice and a non-agricultural (garden) soil and relationships between the ribotypes analysed.

To allow determination of *P. graminis* inoculum levels in plants and soil, a quantitative real-time PCR assay was developed. The assay was used to examine resistance of a variety of wheat cultivars and other *Triticum* genotypes to *P. graminis*.

Materials and Methods

Methods used for the extraction and quantification of DNA from *Polymyxa* zoospores, plants and soil are described in Ward *et al.* (2005). Ribosomal DNA was amplified using primers NS5 or ITS5 in combination with ITS4 and cloned into pGEM-T Easy prior to sequencing (Ward *et al.*, 2005). The real-time PCR assay development, testing and reaction conditions are described in Ward *et al.*, 2005).

Results

Ribosomal DNA sequences were obtained from the roots of rice and wheat plants (Table 1) and comparisons were done with sequences obtained in previous studies (Ward & Adams, 1998; Morales *et al.*, 1999; Legrève *et al.*, 2002; Ward *et al.*, 2005). Rice roots obtained from the Côte

Table 1. Plant samples from which *P. graminis* sequences were obtained.

Sample name	Source	EMBL Accession No.
Afr1	Côte d'Ivoire, rice (Line ISDA 6), D.E. Johnson, via F.Morales	AM075821
Afr2	Côte d'Ivoire, rice (Line Bouake 189), D.E. Johnson, via F. Morales	AM075820
Jap	Japan, rice (cv. Akebono), Satoshi Kashiwazaki	AM075822
Garden	Rothamsted, UK, wheat grown in garden soil, Anna Tymon	AM075823

d'Ivoire containing rice stripe necrosis virus (RSNV; Johnson *et al.*, 1998) and from Japan containing rice necrosis mosaic virus (RNMV) were found to contain *P. graminis* sequences that were very closely related (99.4 - 99.8% identity) to those from the only other previously sequenced rice 'isolate' (associated with transmission of RSNV) from Colombia (Morales *et al.*, 1999). The *Polymyxa* sequences from all three of these samples formed a clade in phylogenetic analyses that was well supported by bootstrapping (Fig. 1). A *P. graminis* sequence was also obtained from wheat grown in a non-agricultural (garden) soil and this was most closely related to ribotype II, (94% identity), but is sufficiently different to warrant being assigned to a separate subgroup (VI).

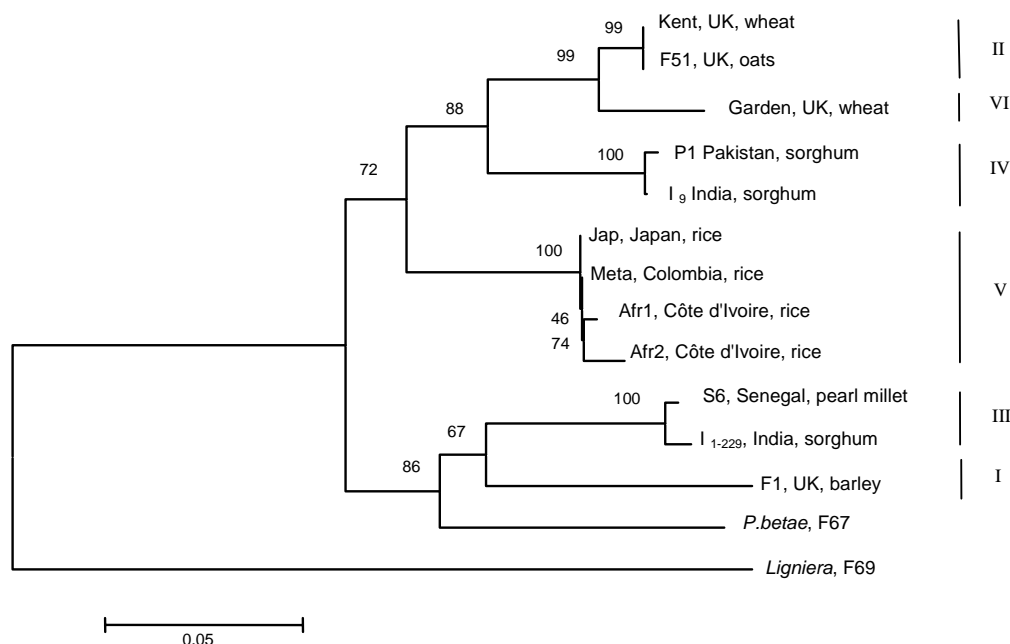

Figure 1. Phylogenetic tree of the ITS5-ITS4 rDNA regions obtained using Neighbour Joining analysis (Tamura-Nei distances) in the package MEGA3 (Kumar *et al.*, 2004). Percentage bootstrap values (1000 replicates) are shown above the forks.

A specific, sensitive and quantitative real-time TaqMan PCR assay for *P. graminis* was developed based on 18S rDNA sequences (Ward *et al.*, 2005). The assay was calibrated with zoospore suspensions and inoculated roots and then shown to work on naturally infected plant roots and infested soil. Testing of roots of different *Triticum* and *Hordeum* genotypes after growing in naturally infested soil, showed that there was a good correlation between the levels of *P. graminis* detected by visual assessment and real-time PCR (Ward *et al.*, 2005).

Discussion

Traditionally, the plasmodiophorids were considered as fungi, but analysis of ribosomal DNA sequences has shown them to be a monophyletic group that is not closely related to the true Fungi nor to other zoosporic plant parasites (the straminipiles, which include the oomycetes, and the chytridiomycetes) (Fig. 2; Ward & Adams, 1998; Bulman *et al.*, 2001). Their most appropriate classification is within the protists, a highly diverse group of eukaryotic organisms; they are most closely related to the *Phagomyxida* (*Phagomyxa* species), and more distantly to the chlorarachneans and sarcomonads (Bulman *et al.*, 2001). They are also related to *Maullinia ectocarpae*, parasites of diatoms and filamentous algae (Fig. 2; Maier *et al.*, 2000; S. Bulman, E. Ward & I. Maier, unpublished). Within the plasmodiophorids, *Ligniera* and *Sorosphaera* appear to be closely related to *Polymyxa*, while *Spongospora* and *Plasmodiophora* are more distant.

Analysis of *P. graminis* sequences found in rice roots from the Côte d'Ivoire and Japan, revealed that they were all closely related to the only other sequenced rice isolate from

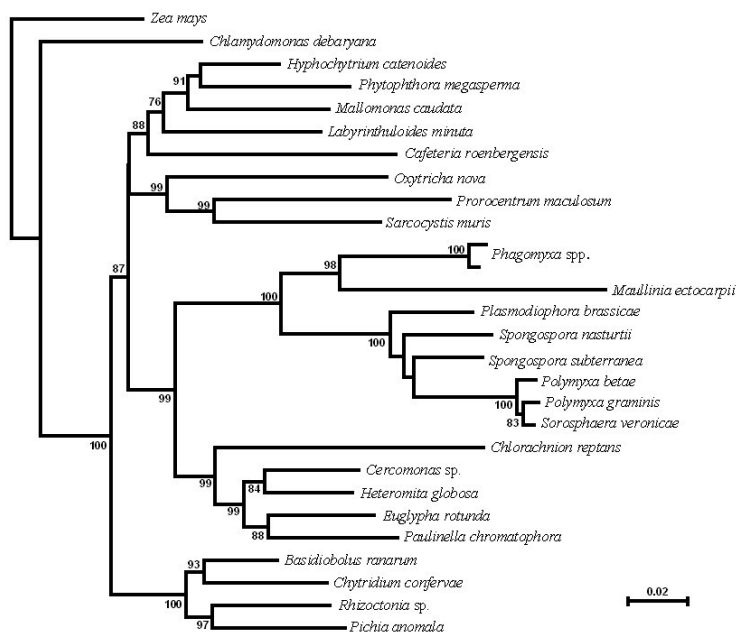

Figure 2. Phylogenetic analysis of 18S rDNA (MEGA3 neighbor joining (Tamura-Nei distances); 10000 bootstrap replicates).

Colombia. These sequences formed a well-supported clade in phylogenetic analyses (Fig. 1) and clearly belong to the same subgroup/ ribotype. It is now clear that this subgroup is widely distributed geographically, being found in South America (Colombia), Asia (Japan) and Africa (Côte d'Ivoire). From the limited information available, it seems possible that this subgroup shows host specificity or preference for rice and it appears to be associated with transmission of both RSNV and RNMV.

During the testing of our real-time PCR assay we obtained a non-agricultural soil sample from a garden at Rothamsted to use as a negative control. When wheat and barley were grown in this soil, no *Polymyxa* was detected in the roots by either microscopy or PCR (Ward *et al.*, 2005). However when a second sample of soil from the same area was used, some of the plants grown in it, were free from *Polymyxa* (using visual assessment and PCR) as expected, but others gave a positive PCR result for *Polymyxa*. CAPS analysis (Ward *et al.* 2005) indicated that the *P. graminis* was ribotype II. Subsequent ITS rDNA sequence

analysis showed that it was closely related, but not identical to other ribotype II sequences (94% identity). In phylogenetic analyses it grouped with ribotype II isolates, with strong support from bootstrapping (Fig. 1) and we have tentatively assigned it to a new subgroup/ ribotype (VI). We do not know whether this 'isolate' is capable of transmitting any viruses or is present in agricultural soils, and its significance to the epidemiology of soil-borne viruses is unknown.

The real-time quantitative PCR assay is proving useful in the determination of inoculum levels and particularly in the investigation of host-plant resistance to *P. graminis*. Recently another real-time PCR assay was also used for *P. graminis* quantification (Ratti *et al.*, 2004) although in this case the assay was not specific for *P. graminis*. The assay was apparently designed 'to detect a range of plasmodiophoraceous species including *P. graminis*'. However, our analysis of the primer and probe sequences revealed that they show 100% homology to *P. betae* only; there were mismatches to *P. graminis* sequences in the forward primer and the TaqMan probe. These differences suggest that the assay may not be well-optimized for *P. graminis* and make its specificity uncertain.

We thank Francisco Morales, David E. Johnson and the late Satoshi Kashiwazaki for *Polymyxa*-infected rice samples. Rothamsted Research receives grant-aided support from the Biotechnology and Biological Sciences Research Council of the United Kingdom.

References

- Bulman, S.R., Kühn, S.F., Marshall, J.W. and Schnepf, E. (2001) A phylogenetic analysis of the SSU rRNA from members of the plasmodiophora and phagomyxida. *Protist* **152**, 43-51.
- Johnson, D.E., Dingkuhn, M., Fomba, S.N. and Morales, F. (1998) Incidence of rice stripe necrosis virus in upland rice in West Africa. *International Rice Research Notes* **23** (3) 25-26.
- Kanyuka, K., Ward, E. and Adams, M.J. (2003) *Polymyxa graminis* and the cereal viruses it transmits: a research challenge. *Molecular Plant Pathology* **4**, 393-406.
- Kumar, S., Tamura, K. and Nei, M. (2004) MEGA3: Integrated software for molecular genetics analysis and sequence alignment. *Briefings in Bioinformatics* **5**, 150-163.
- Legrève, A., Delfosse, P. and Maraite, H. (2002) Phylogenetic analysis of *Polymyxa* species based on nuclear 5.8S and internal transcribed spacers ribosomal DNA sequences. *Mycological Research* **106**, 138-147.
- Maier, I., Parodi, E., Westermeier, R. and Müller, D.G. (2000) *Maullinia ectocarpii* gen. et sp. nov. (Plasmodiophorea), an intracellular parasite in *Ectocarpus siliculosus* (Ectocarpales, Phaeophyceae) and other filamentous brown algae. *Protist* **151**, 225-238.
- Morales, F.J., Ward, E., Castano, M., Arroyave, J.A. and Adams, M.J. (1999) Emergence of rice stripe necrosis virus in South America. *European Journal of Plant Pathology* **105**, 643-650.
- Ratti, C., Budge, G., Ward, L., Clover, G., Rubies-Autonell, C. and Henry, C. (2004) Detection and relative quantitation of Soil-borne cereal mosaic virus (SBCMV) and *Polymyxa graminis* in winter wheat using real-time PCR (TaqMan). *Journal of Virological Methods* **122**, 95-103.
- Ward, E. and Adams, M.J. (1998) Analysis of ribosomal DNA sequences of *Polymyxa* species and related fungi and the development of genus- and species-specific PCR primers. *Mycological Research* **102**, 965-974.
- Ward, E., Kanyuka, K., Motteram, J., Korniyukhin, D. and Adams, M.J. (2005) The use of conventional and quantitative real-time PCR assays for *Polymyxa graminis* to examine host plant resistance, inoculum levels and intraspecific variation. *New Phytologist* **165**, 875-885.

OCCURRENCE AND SIGNIFICANCE OF THE TEMPERATE RIBOTYPES OF *POLYMYXA GRAMINIS*

M. J. Smith, E. Ward and M.J. Adams

Wheat Pathogenesis Programme, Plant-Pathogen Interactions Division, Rothamsted Research, Harpenden, Herts AL5 2JQ, UK

Summary

A number of subgroups of *Polymyxa graminis* have been separated on the basis of their rDNA sequence. Isolates of *P. graminis* found on temperate cereals can similarly be divided into two subgroups known as ribotypes I and II. Nothing is known about the biological significance of these ribotypes with regard to host range and virus transmission. Initial studies have been directed towards testing of *P. graminis* associated with virus infested soils especially those from an agricultural site in Wiltshire, England known to be infested with Soil borne cereal mosaic virus (SBCMV). A number of wheat cultivars and wild wheat relatives were grown in this soil under controlled environment conditions. Initial results show that both ribotypes of *P. graminis* are present in this soil but that ribotypes may exhibit host specificity.

Introduction

Polymyxa graminis is a root-infecting commensalistic organism known to infect a number of grass and cereal species. It is unusual in the fact that it transmits plant pathogenic viruses from at least five different genera. These viruses are of agronomic importance around the world causing severe yield losses. Little is known about *P. graminis* and the biological significance of the recently identified subgroups of the species (Kanyuka *et al.*, 2003). However there is already some evidence to suggest that these ribotypes differ in their ability to transmit SBCMV (Ward *et al.*, 2005). Initial studies were conducted on wheat and wild wheat relatives grown in soil from a site in Wiltshire, UK, known to be infested with SBCMV. The plants were then analysed by ribotype-specific PCR assays to determine which of the two ribotypes of *P. graminis* were present in their roots. Results from these experiments are presented and their implications discussed.

Materials and Methods

Wheat cultivars and grass species (Table 1) were sown in a 1: 2 mix of soil and sharp sand from a SBCMV infected field in Wiltshire, England. The plants were grown for 5 weeks with a 14 hr photoperiod at 20°C (night period 14°C) to allow development of viral symptoms. Plants were then tested for the presence of SBCMV in leaves and roots using an indirect F(ab)₂ ELISA (Chen *et al.*, 1991). In addition, total DNA was extracted from root tissue using the method described by Ward *et al.* (2005). Conventional PCR using two *Polymyxa graminis* specific primer sets PgF1/R1 (Pg.F1: 5'-AAC ATG TGG ATT GTG GGC TAT GTG-3', PgR1: 5'-AAC TCC CAT TCT CCA CAA CGC AA-3') and PgF2/R2 (PgF2:5'-ATG TGG ATC GTC TCT GTT GCT GGA-3', PgR2: 5'-CCT CAT CTG AGA TCT TGC CAA GT-3') was then used to determine the ribotypes of *Polymyxa graminis* present in the root tissue (Ward *et al.*, 2005). These assays are specific for their respective ribotypes and amplify products of 292 (type I) or 430 (type II) bp (Fig. 1).

Results

When tested by ELISA, SBCMV was detected in roots of the resistant control *Triticum aestivum* cv. Cadenza and significant, but smaller, signals were obtained from leaves of the susceptible control cv. Avalon and from one sample of cv. Nikoniya. It seems unlikely that any of the other cultivars or wild relatives were infected with SBCMV (Table 1).

In PCR tests, both types of *P. graminis* were detected but type II was more common. One sample was infected with both types and some samples appeared not to be infected (Table 1 and Fig. 1).

Table1. Absorbance values in ELISA for the detection of SBCMV and *Polymyxa graminis* ribotype detection by PCR using samples of wheat cultivars and wild relatives grown in Wiltshire soil

Triticum, Aegilops, and Dasypyrum species	tissue	ELISA ¹		<i>P. graminis</i> ² Ribotype
		1	2	
<i>Triticum spelta</i> v. <i>caeruleum</i> UA 0300074,IR00127	root	0.013	0.017	II
<i>Aegilops geniculata</i> 26/93	root	0.022	0.025	-
<i>Aegilops tauchsii</i>	root	0.126	0.122	I,II
<i>Aegilops tauchsii</i>	root	0.041	0.044	II
<i>Triticum aestivum</i> cv. Cadenza (SBCMV resistant)	root	2.080	2.159	nt
<i>Triticum aestivum</i> cv. Nikoniya	leaf	-0.02	0.012	II
<i>Triticum aestivum</i> cv. Nikoniya	leaf	0.926	0.821	II
<i>Dasypyrum villosum</i>	root	0.018	0.019	-
<i>Dasypyrum villosum</i>	leaf	0.006	0.008	-
<i>Triticum boeoticum</i> k1814/96	leaf	-0.01	0.007	-
<i>Triticum aestivum</i> cv. Kuyalnik	leaf	-0.01	-0.01	-
<i>Triticum aestivum</i> cv. Kolumbiya	leaf	-0.01	-0.01	-
<i>Triticum aestivum</i> cv. Donskaya	leaf	-0.01	0.019	-
<i>Triticum aestivum</i> cv. Avalon (SBCMV susceptible)	leaf	0.278	0.298	II

¹ ELISA (A_{405}) values after c. 1h incubation with substrate. Values (1 and 2) are from two separate plates (means of two replicate wells)

² Deduced from PCR banding patterns of root samples I, ribotype I; II, ribotype II; -, negative; nt, not tested

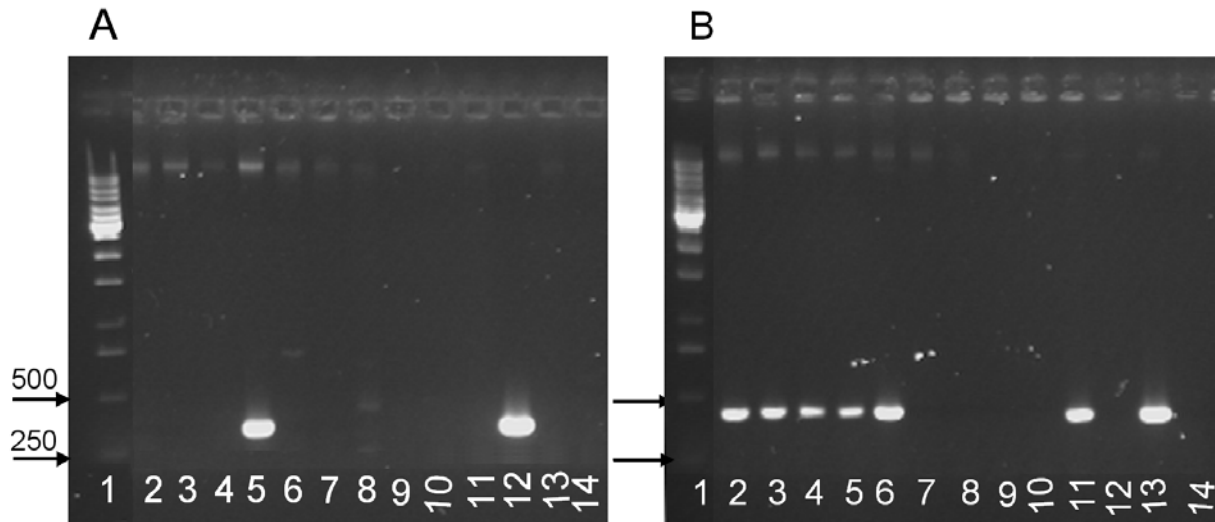

Fig. 1. Agarose gels showing bands amplified from roots of plants grown in Wiltshire soil using **A** *P. graminis* ribotype I specific primers Pg F1/R1 (expected band size 292 bp) or **B** ribotype II specific primers Pg F2/R2 (expected band size 430 bp). Lane 1: 1kb ladder (Promega); lane 2: *Triticum aestivum* cv. Nikoniya; lane 3: *T. aestivum* cv. Nikoniya; lane 4 : *T. spelta*; lane 5: *Aegilops tauschii*; lane 6: *A. tauschii*; lane 7: *A. geniculata*; lane 8: *Dasypyrum villosum*; lane 9: *T. boeoticum*; lane 10: *D. villosum*; lane 11: *T. aestivum* cv. Avalon; lane 12: Type I DNA from infected root *Hordeum vulgare* cv. Maris Otter; lane 13: Type II DNA from infected root *T. aestivum* cv. Avalon; Lane 14: DNA from non-infected root *T. aestivum* cv. Mercia.

Discussion

This preliminary study shows that both ribotypes of *P. graminis* are present in the soil at the Wiltshire site as both can be found in the roots of these lines. However both ribotypes are not present in all lines. Ribotype II *P. graminis* was present in some *Triticum* species but not all. *Aegilops tauchsii* was the only line to have both types present in the roots of one of the plants, although the other plant in this test only had type II present. This probably reflects the natural variation of inoculum present in the soil.

The strongest ELISA signal for the detection of SBCMV was from the roots of the resistant cultivar Cadenza. This is not unexpected because the resistance in this cultivar is mediated by a mechanism preventing movement from roots to shoots (Kanyuka *et al.*, 2004; Hunger *et al.*, 1985).

Further, much larger scale experiments are needed to confirm these results as only one or two plants were tested in each case. If these results are borne out, there may be implications for virus epidemiology. *Aegilops tauchsii*, the D genome donor to *Triticum aestivum*, is susceptible to infection by both types of *P. graminis*.

These data from the Wiltshire site are similar to data from a site in Kent, UK also infested with SBCMV. In this soil both ribotypes of *P. graminis* are also present but ribotype II was always found in plants infected with SBCMV. Ribotype I was sometimes found along with ribotype II in SBCMV infected plants but not always (Ward *et al.*, 2005).

In work by Ratti *et al.*, 2004, hexaploid wheat varieties grown in SBCMV-infested soil in the UK were analysed using our Pxfwd1/ Pxrev7 conventional PCR assay (Ward *et al.*, 1998), which allows discrimination between *P. betae* (265bp product), *P. graminis* ribotype type I (280bp) and

P. graminis ribotype II (320bp). The authors report that the assay consistently gave a 280bp product but made no comment about *P. graminis* ribotypes. If this reported size is accurate, it would indicate that all of their samples (including those containing SBCMV) contained only *P. graminis* ribotype I whereas our results suggest that SBCMV is always associated with ribotype II. Unfortunately, their paper does not provide any gel images, but their comment that the assay 'distinguishes between *P. betae* and *P. graminis* by producing PCR products of 265 and 280bp respectively' indicates that they may not have appreciated the difference in size between the ribotypes. However, it is possible that the size of the band may not have been reported accurately. It would be interesting if the samples were retested alongside known ribotype I and ribotype II samples to clarify which ribotypes were present.

We thank Dr. Anastasiya Zlatska for the ELISA data. Rothamsted Research receives grant-aided support from the Biotechnology and Biological Sciences Council of the United Kingdom

References

- Chen, J.P., and M.J. Adams. (1991). Serological relationships between five fungally transmitted cereal viruses and other elongated viruses. *Plant Pathology* **40**:226-231.
- Hunger, R.M., and J.L. Sherwood. (1985). Use of symptomatology and virus concentration for evaluating resistance to wheat soilborne mosaic virus. *Plant Disease* **69**:848-850.
- Kanyuka, K., D.J. Lovell, O.P. Mitrofanova, K. Hammond-Kosack, and M.J. Adams. (2004). A controlled environment test for resistance to Soil-borne cereal mosaic virus (SBCMV) and its use to determine the mode of inheritance of resistance in wheat cv. Cadenza and for screening *Triticum monococcum* genotypes for sources of SBCMV resistance. *Plant Pathology* **53**:154-160.
- Kanyuka, K., Ward, E., Adams, M, J.(2003). *Polymyxa graminis* and the cereal viruses it transmits: a research challenge. *Molecular Plant Pathology* **4**:393-406.
- Ratti, C., Budge, G., Ward, L., Clover, G., Rubies-Autonell, C., Henry, C. (2004). Detection and relative quantitation of Soil-borne cereal mosaic virus (SBCMV) and *Polymyxa graminis* in winter wheat using real-time PCR (Taqman). *Journal of Virological Methods* **122**:95-103.
- Ward, E., Kanyuka, K., Motteram, J., Korniyukhin, D., Adams, M. J. (2005). The use of conventional and quantitative real-time PCR assays for *Polymyxa graminis* to examine host plant resistance, inoculum levels and intraspecific variation. *New Phytologist* **165**:875-885.
- Ward, E., and Adams M.J. (1998). Analysis of ribosomal DNA sequences of *Polymyxa* species and related fungi and the development of genus- and species- specific PCR primers. *Mycological Research* **102**:965-974.

SOROSPHAERA VITICOLA NOM. PROV., A NEWLY DISCOVERED PLASMODIOPHORID, A POTENTIAL VECTOR FOR GRAPE VINE VIRUSES?

Martin Kirchmair¹, Sigrid Neuhauser¹, Christa Scholz² and Lars Huber²

¹Institute of Microbiology, Leopold Franzens-University of Innsbruck, Technikerstr. 25, 6020 Innsbruck, Austria

martin.kirchmair@uibk.ac.at

²Institute of Zoology, Johannes Gutenberg-University of Mainz, Müllerweg 6, 55099 Mainz, Germany

Summary

In the context of an interdisciplinary project on grape pests and pathogens in the German Rheingau, the fine root system of grafted rootstocks has been screened for pathogenic fungi associated with root galls induced by grape phylloxera (*Daktulosphaira vitifoliae* (Fitch)). In several insect-induced galls, masses of resting spores of a plasmodiophorid could be seen. An additional selective screening revealed the occurrence of the plasmodiophorid parasite also in samples of gall-free rootlets: cortical cells of small necrotic areas were crowded with resting spores. According to current taxonomic concepts, this plasmodiophorid could be identified as a member of the genus *Sorosphaera* Schroeter. Considering the fact that some plasmodiophorids cause economic losses by transmission of plant viruses, the new grape plasmodiophorid might represent a promising target for future research. Grapevines also suffer from different viruses and some of their organismic vectors are still unknown. Viruses transmitted by *Polymyxa graminis* and other plasmodiophorids show certain physical and biochemical properties, like nonenveloped filamentous virions with single stranded RNA genomes, which are similar to the characteristics of grapevine chlosteroviruses. The watercress yellow spot virus (WYSV), transmitted by *Spongospora narsurtii*, probably belongs to the same family (Tombusviridae) like the Grapevine Algerian latent virus (GALV) and the Petunia asteroid mosaic virus (PeAMV).

Introduction

Plasmodiophorids are found in soil, fresh water or marine habitats and are obligate endobionts of plants (e.g. flowering plants and green algae) and stramenopiles (e.g. brown algae, diatoms, and oomycetes). Thus, their distribution follows that of their hosts; no member conclusively has been shown to complete a life cycle in absence of host cells (Dylewski, 1990; Braselton, 2001). Many plasmodiophorids are parasitic on food plants, for example, *Plasmodiophora brassicae* Woronin (club root disease of cabbage and other crucifers) or *Spongospora subterranea* (Walr.) Lagerheim f.sp. *subterranea* (powdery scab disease of potatoes). It might be even more important that some plasmodiophorids cause economic loss by the transmission of plant viruses.

Fig 1-3. *Sorosphaera viticola*. 1. SEM micrographs of mature sporosori (bar = 10 μ m). 2. Autofluorescence (440 – 480 nm) of sporosori accumulated in and around scars of broken off fine roots (bar = 1 mm). 3. Autofluorescence of sporosori at 440-480 nm (bar = 20 μ m)

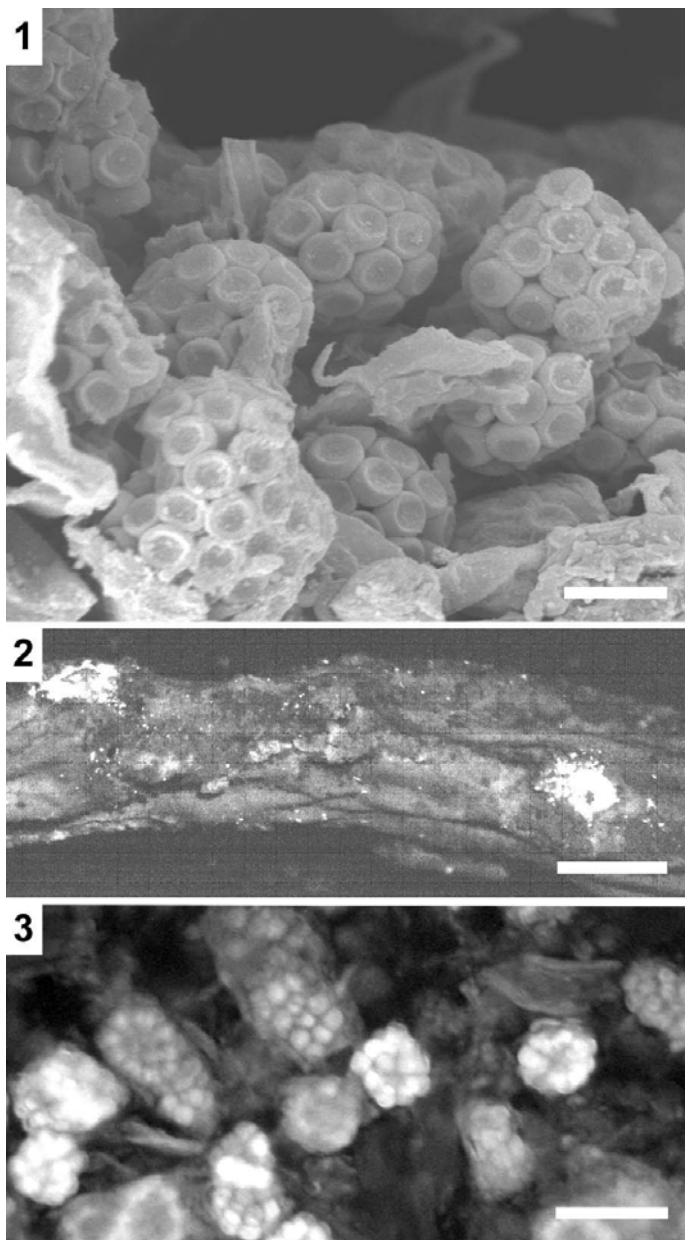

been planted with *Vitis riparia* x *V. berlandieri* SO4. The emphasis of this screening was to examine our hypothesis that phylloxera induced root galls, so called nodosities, constitute, because of their fissured surface, a preferential target for fungal invaders. For this purpose, root samples were taken from ten randomly chosen rootstocks. In the cortical tissue of some isolated root galls, masses of conspicuously structured plasmodiophorid sporosori were found (Huber et al. 2004). In an additional selective screening in 8 randomly chosen rootstocks the parasite could be observed in fresh root segments without phylloxera induced hypertrophies. No evident disease pattern, with the exception of small root necroses and probably an early

Materials and Methods

Sampling:

Roots from the upper 25-cm soil horizon were sampled with a spade. Three samples were taken from each vine: two samples were taken 10–15 cm to the left and right of the trunk, underneath the row; the third was taken from the middle of the row opposite the trunk (Porten and Huber 2003).

Scanning electron microscopy (SEM): Rootlets were fixed for 30 minutes in 2.5% watery glutaraldehyde (v/v). After washing in 30% ethanol, samples were dehydrated in ascending concentrations of ethanol and transferred into 100% acetone. Specimens were then critical-point dried, mounted on aluminium stubs, and subsequently sputtered with gold. Micrographs were taken at 30 kV acceleration voltage using a PHILIPS ESEM scanning electron microscope.

Epifluorescence microscopy: Scanning roots for the presence of *Sorosphaera* infestation was carried out with the help of a Leica MZFLIII fluorescence stereo microscope (Filter GFP2 480/40 nm).

Results and Discussion

In the context of an interdisciplinary project on grape pests and pathogens, phylloxera infested root samples from a vineyard near Kiedrich (50° N; 8° E; 160 m asl) in the German Rheingau were screened for fungal colonisation. The vineyard has

reddening could be correlated with the infection. Cortical cells within the necrotic areas were crowded with sporosori or contained plasmodial stages of the parasite. The spherical sporosori with an average diameter of 12 μm are formed by 15 to 50 peripherically arranged resting spores leaving a hollow centre (Fig. 1). The individual resting spores are thick-walled, saucer shaped, roundish to somewhat polygonal in plan view, measuring 4-5 μm in diameter and 2.5-3 μm in total height (side view). The relatively constant shape of mature sporosori as well as hollow spheres led to the conclusion that the new grapevine parasite should be included within the genus *Sorosphaera* and has been described as *Sorosphaera viticola* Kichmair, Neuhauser & Huber (Kirchmair et al. 2005).

A yellowish-green autofluorescence at 440 - 480 nm of the sporosori of *Sorosphaera veronicae* J. Schroet. was described by Neuhauser et al (2005). An autofluorescence of the sporosori could also be observed in *S. viticola* (Scholz, 2005; Figs. 2 - 3). This characteristic trait was used to screen an individual rootstock and the entire vineyard for *Sorosphaera* infestations. Cortical tissues infected with *S. viticola* were dispersed irregularly over the root system, but accumulations of sporosori could be found around scars of broken off fine roots (Fig. 2). In the conventional managed vineyard in Kiedrich nearly every rootstock was found to be infested by *Sorosphaera* (Fig. 4). A part of the vineyard was used for fertilization experiments in 2003 and mucked with about 1 kg cow dung per vine. In this part no *Sorosphaera* infestation could be observed. It remains a speculation if muck protects grapevines against *Sorosphaera* or if the parasite - starting from an infective focus - has not spread over the entire vineyard until now. In Geisenheim, about ten kilometer afar from Kiedrich, an organic managed vineyard was screened for *Sorosphaera*. At this locality, areas with infected roots were interrupted by sites with vines in which no *Sorosphaera* infestation was detectable.

The vineyard in Kiedrich was planted with 'Pinot Noir' on SO4. This rootstock is a hybrid of *V. berlandieri* Planch x *V. riparia* Michx. In Geisenheim, *S. viticola* was found in roots of 5C, also a hybrid of *V. berlandieri* x *V. riparia*. One can speculate that this plasmodiophorid was introduced to Europe when it became necessary to graft American rootstocks to *V. vinifera* plants after the phyloxera epidemic of the 1870s.

Many plasmodiophorids are parasitic on food plants, for example, *Plasmodiophora brassicae* or *Spongospora subterranea* f.sp. *subterranea*. It might be even more important that some plasmodiophorids cause economic loss by the transmission of plant viruses. Among them, several cereal viruses, for instance the soil-borne wheat mosaic virus (SBWMV), or the oat mosaic virus (OMV), are transmitted by *Polymyxa graminis* Ledingham whereas *Polymyxa betae* Keskin is the vector of BSBV, the beet soil-borne virus (Adams, 1991). Grapevines suffer from different viruses and that some of their organismic vectors are still unknown (Bovey et al. 1980, Frison & Ikin 1991). As far as we are aware of, nearly none of the known grapevine viruses is related to viruses transmitted by plasmodiophorids, The watercress yellow spot virus (WYSV) – transmitted by *Spongospora subterranea* f.sp. *nasturtii* J.A. Toml. - probably belongs to the same family (Tombusviridae, Clay & Walsh 1997) like the Grapevine Algerian latent virus (GALV) or the Petunia asteroid mosaic virus (PeAMV).

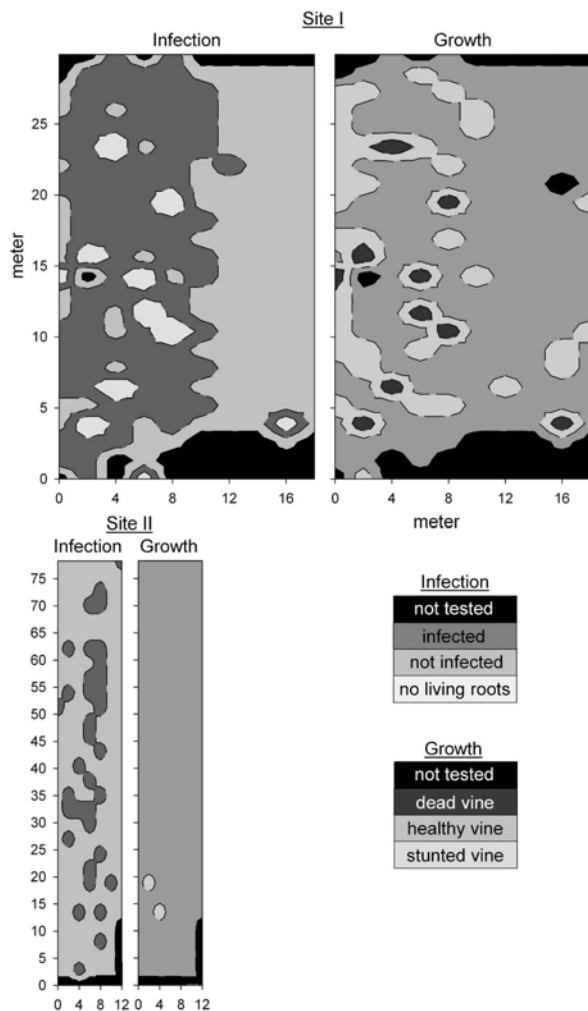

Fig. 4. Distribution of *Sorospaera viticola* in two vineyards. Site 1: Kiedrich; conventional managed vineyard. Site 2: Geisenheim; organic managed vineyard.

References

- Adams, M., J. (1991). Transmission of plant viruses by fungi. *Ann. Appl. Biol.* **118**: 479-492.
- Braselton, J. P. (2001) Plas-modiophoromycota In: *The Mycota VII, Part A, Systematics and Evolution* (eds. McLaughlin D. J., McLaughlin E. G., Lemke P. A.), Springer Verlag, New York: 81-91.
- Clay, C., M. and Walsh, J. A. (1997) Watercress yellow spot virus (WYSV): cytopathic alterations suggest it is a member of the Tombusviridae. *Proceedings of the 3rd Symposium of the International Working Group on Plant Viruses with Fungal Vectors*, 6-7 August, 1996, Dundee, Scotland, U.K., 101-104.
- Dylewski, D., P. (1990). Phylum Plas-modiophoramycota. In: Margulis L, Corliss JO, Melkonian M and Chapman DJ (eds.) *Handbook of Protoctista* (pp. 399-416) Jones and Barlett Publishers, London.
- Huber, L., Hammes, M., Eisenbeis, G., Pöder, R. and Kirchmair, M. (2004). First record of a plasmodiophorid parasite in grapevine. *Vitis* **43**: 187-189.

Some diseases of grapevine are not fully understood and new viruses affecting grapevine are being discovered. It might be promising to screen grape vines for the presence of viruses with plasmodiophorid vectors.

Acknowledgements

The authors wish to thank James P. Braselton, Professor Emeritus, Ohio University, Athens (USA) and Simon Bulman, PhD, Lincoln University, Christchurch, New Zealand providing valuable comments. We are indebted to R. Pöder, University of Innsbruck, Austria for passing on his knowledge and expertise. This work was partially supported by the Deutsche Forschungsgemeinschaft (DFG; project EI 87/9-1), the Feldbausch Foundation, Department of Biology, University of Mainz and the Heinrich-Birk-Gesellschaft e.V., Geisenheim.

- Kirchmair, M., Neuhauser, S. and Huber, L. (2005). *Sorosphaera viticola* spec. nov. (Plasmodiophorids), an intracellular parasite in roots of grape vine. *Sydowia* **57**: in press.
- Neuhauser, S., Kirchmair, M. and Huber, L. (2005). *Sorosphaera veronicae*, neu für Österreich. *Österr. Z. Pilzk.* **14**, in press
- Porten, M. and Huber L. (2003). An assessment method for the quantification of *Daktulosphaera vitifoliae* (Fitch; Hemiptera: Pylloxeridae) populations in the field. *J. Appl. Entomol.* **127**: 157-162.
- Scholz, C. (2005) Untersuchungen zur Verteilung von *Sorosphaera viticola* nom. prov. (Plasmodiophorales) im Wurzelgewebe von Unterlagsreben (*Vitis* spp.) im Freiland. Diploma thesis. Institute of Zoology, Gutenberg University Mainz.

MOLECULAR METHODS FOR THE DETECTION OF *POLYMYXA GRAMINIS* F. SP. *TEMPERATA* AND *P. GRAMINIS* F. SP. *TEPIDA* IN ASSOCIATION WITH BYMO- AND FUROVIRUSES

Céline Vaïanopoulos, Claude Bragard, Henri Maraite and Anne Legrève

Unité de phytopathologie, Université catholique de Louvain, Croix du Sud 2/3, B-1348 Louvain-la-Neuve, Belgium.

Summary

Polymyxa graminis is the vector of bymo- and furoviruses responsible for several cereal diseases in temperate areas. Two *formae speciales*, *P. graminis* f. sp. *temperata* and *P. graminis* f. sp. *tepida*, distinguished on the basis of their ribosomal DNA sequences, have been identified in these areas. Nested and multiplex PCR, RFLP analysis of PCR-amplified rDNA and quantitative real-time PCR, using specific primers or restriction enzymes targeting the specific sequences of the internal transcribed spacers one or two (ITS1 or ITS2) of these *formae speciales*, were developed in order to identify and quantify them. These methods were used to characterize the *P. graminis* populations colonizing barley, rye and wheat roots in a bioassay on two Belgian soils and one French soil infested by one or more of the bymoviruses, *Barley yellow mosaic virus* (BaYMV), *Barley mild mosaic virus* or *Wheat spindle streak mosaic virus* (WSSMV) and/or the furoviruses, *Soil-borne cereal mosaic virus* and related virus species. Both *P. graminis* f. sp. *temperata* and *P. graminis* f. sp. *tepida* were isolated from the three soils tested but the former was found mainly on barley and the latter on wheat. On rye, a different ribotype was obtained, with a sequence closer to *P. graminis* f. sp. *temperata* than *P. graminis* f. sp. *tepida*. Co-infection of bymoviruses (BaYMV and WSSMV) and/or furoviruses with *P. graminis* f. sp. *temperata* and/or *P. graminis* f. sp. *tepida* was observed on both barley and wheat. These findings demonstrated a greater diversity in the vector populations than previously reported in Belgium and France. The results also suggest a certain but not exclusive specialization in plant/*P. graminis formae speciales*/virus interactions. The relevance of these observations to the epidemiology of the *P. graminis*-transmitted viruses is discussed.

Introduction

Polymyxa graminis Ledingham, a plasmodiophorid, is the vector of mosaic diseases on cereals caused by bymoviruses such as *Barley yellow mosaic virus* (BaYMV), *Barley mild mosaic virus* (BaMMV) and *Wheat spindle streak mosaic virus* (WSSMV) and by furoviruses such as *Soil-borne cereal mosaic virus* (SBCMV) and related virus species. *P. graminis* is an obligate root endoparasite and it ensures viral particle persistence in the soil over a long period.

On the basis of the genomic and ecological characteristics of *P. graminis* associated with the transmission of different viruses in temperate and tropical areas, five *formae speciales* of *P. graminis* were identified by Legrève *et al.* (2002). Two *formae speciales*, *P. graminis* f. sp. *temperata* (*P. g. temperata*) and *P. graminis* f. sp. *tepida* (*P. g. tepida*), occur in the temperate regions. They correspond to the ribotype I and II described by Ward *et al.* (2005), respectively. These authors found that the ribotype I is associated mainly with barley, while the ribotype II occurs mainly on wheat and is involved in SBCMV transmission.

In order to evaluate the specialization of the interactions between plant, *P. graminis formae speciales* and the viruses occurring in temperate areas, RFLP analysis of PCR-amplified rDNA, nested and multiplex PCR and real-time quantitative PCR were developed.

Materials and Methods

Eleven rDNA sequences of *P. graminis* Belgian isolates from barley, rye and wheat plants were obtained after the sequencing of DNA amplified by PCR using Psp1 and Psp2rev primers (Legrève *et al.*, 2003) amplifying a rDNA region stretching from the 3' terminal of the nuclear small rDNA region to the 3' end of 5.8s gene (Vaïanopoulos, unpublished data). These sequences were aligned with published sequences from *P. g. temperata* and *P. g. tepida* (accession numbers AJ311572, AJ311573, AJ311574, Y12824 and Y12826) using the ClustalW program to determine specific regions in order to develop molecular tools for the detection and discrimination of these two *formae speciales*.

RFLP. On the basis of sequences specific for *P. g. temperata* and *P. g. tepida*, the restriction enzymes *Sall* and *Nrul* were selected for a specific digestion. *Sall* allows only the digestion of *P. g. tepida* rDNA in one site in nuclear small rDNA, whereas *Nrul* cuts only in the internal transcribed spacer one (ITS1) of *P. g. temperata* rDNA. The PCR products obtained by PCR using Psp1 and Psp2rev primers (Legrève *et al.*, 2003) were digested with restriction enzymes *Sall* and *Nrul* (Roche, Germany) (10 U/μl) in the appropriate buffer overnight at 37°C. The enzymes were then inactivated for 15 minutes at 65°C. After this, 2 μl of loading buffer were added and the products were loaded on 2% agarose gel in Tris Borate-EDTA buffer. The electrophoresis was performed in Sub-Cell® GT Agarose Gel Electrophoresis Systems Bio-Rad. After ethidium bromide staining, the bands of DNA were visualized using the Gel Doc 2000 (Bio-Rad, USA). Two fragments of 152 bp and 348 bp were expected after the digestion of *P. g. tepida* using *Sall* and two other of 295 bp and 177 bp were expected after the digestion of *P. g. temperata* using *Nrul*.

Nested and multiplex PCR. Two specific primer pairs were designed using the 'eprimer3' WEMBOSS program and targeting specifically the sequence of ITS1 rDNA: PgtempN-F (AGCGTTGAATTGGTCTTGGT) and PgtempN-R (TAGCCAATTCTCCCGAGTTC) for amplifying a region of 102 bp of *P. g. temperata*, and PgtepN-F (TAGCGTTGAATGGTTGTTGC) and PgtepN-R (TTCGACTTTAGCCACCGTTT) for amplifying a region of 128 bp of *P. g. tepida*. The specificity of these primers was assessed using BLAST software (Altschul *et al.*, 1990). For the nested PCR, the Psp1 and Psp2rev primers were used as external primers according to the protocol described by Legrève *et al.* (2003) except that only 0.1 μl of each primer (Psp1 and Psp2rev, at 20 μM) were used. After 10 cycles, 0.5 μl of each internal primer (PgtempN-F/PgtempN-R or PgtepN-F/PgtepN-R) were added to the tube and the PCR was conducted under the same conditions for a further 25 cycles. The three primer pairs were also tested in multiplex PCR under the same conditions over 35 cycles.

Real-time PCR. In order to quantify *P. g. temperata* and *P. g. tepida* by real-time quantitative PCR, specific primers and TaqMan probes were designed on the basis of specific sequences of ITS1 and ITS2 rDNA using the Beacon Designer 3 program of Biosoft International. The Pgtemp-F (GGAGTTGCAGCCCGCATG) and Pgtemp-R (CGCCATGACGGATTGTCGTT) primers and Pgtemp-S probe (Texas red-5'AGTCAGCACGTTCGGCCAAAGTCCA3'-BHQ-2) target a region of the ITS2 of *P. g. temperata* rDNA and the Pgtep1-F (AATGTGGATCGTCTCTGTTGCTG) and Pgtep1-R (CACCGTTTTGATCCAATTCGTGAA) primers and Pgtep1-S probe (FAM-5'CGGGATGGAACGCCCTCGTGGTGG3'-BHQ-1) target a region of the ITS1 of *P. g. tepida* rDNA. The specificity of the primers was tested using SYBR Green chemistry. The mixture for the real-time PCR was prepared with 12.5 μl 2 x iQ™ Supermix (Bio-Rad, USA), 2.5 μl of reverse primer at 300 nM, 2.5 μl of forward primer at 300 nM, 2.5 μl of probe at 100 nM, 2.5 μl of DEPC-treated water and 2.5 μl of DNA diluted to 1:10. The amplification reaction was conducted with the Bio-Rad® iCycler (Bio-Rad, USA) as follows: first denaturation at 95°C for 3 minutes, 40 cycles each composed of (i) 95°C for 15 seconds and (ii) 60°C for 1 minute.

Plant material for the validation of molecular methods and for the specialization evaluation. The methods developed were validated with DNA extracts from clones containing a part of rDNA of *P. g. temperata* and *P. g. tepida* (fragment amplified by PCR using Psp1 and Psp2rev) isolated on barley, rye and wheat plants from Belgian soils. DNA extracts from reference isolates of *P. graminis* f. sp. *tropicalis* and *P. graminis* f. sp. *subtropicalis* (MUCL references 43177 and 43182, respectively, Legrève *et al.*, 2002) were included in the PCR tests to evaluate the specificity of the methods. All the DNA extracts were performed according to the protocol described by Legrève *et al.* (2003). In order to evaluate the specialization of the *P. graminis formae speciales*, the methods were applied on DNA extracts from bait plants (barley cv. Tiffany, rye cv. Halo and wheat cv. Cezanne) grown in three soil samples collected at Chambon-sur-Cisse (France) infested by SBWMV and WSSMV, at Flavion (Belgium) infested by furoviruses and WSSMV and at Gembloux (Belgium) known for its natural infestation by BaYMV and BaMMV. After 15 weeks growth, the infection of plants by *P. graminis* and viruses was assessed by PCR (Legrève *et al.*, 2003) and RT-PCR (Vaïanopoulos *et al.*, 2003 and submitted). Bait plants infected by *P. graminis* and viruses were transferred with healthy barley, rye and wheat plants into automatic immersion systems (Legrève *et al.*, 1998) to multiply viruliferous *P. graminis* cultures. Every 3 weeks, some plants were removed from the system and replaced by healthy plants. Root samples were collected and tested in order to assess the infection by *P. graminis* and the viruses associated. In addition, several barley and wheat cultivars collected in Chambon-sur-Cisse, Flavion and Gembloux fields were analysed using the molecular methods developed.

Results

The *P. graminis* sequences obtained from the barley and wheat plants correspond to the published sequences of *P. g. temperata* and *P. g. tepida*, respectively (99% homology). The sequence isolated from rye plants was slightly different, but closer to the *P. g. temperata* sequences (93% homology) than to the *P. g. tepida* one. The molecular tools developed in this study were selected in the common parts of *P. graminis* sequences from barley and rye considering that the *formae speciale* isolated on rye is strongly associated with *P. g. temperata*.

The tests performed on reference isolates of *P. g. temperata*, *P. g. tepida*, *P. graminis* f. sp. *tropicalis* and *P. graminis* f. sp. *subtropicalis* showed that the RFLP analysis, the nested and multiplex PCR and the real-time PCR, using specific primers or restriction enzymes targeting the specific sequences of the ITS1 or ITS2 of *P. g. temperata* and *P. g. tepida*, were specific to these two *formae speciales*. No cross-reaction with *P. graminis* f. sp. *tropicalis* and f. sp. *subtropicalis* was observed. In addition, no PCR product was obtained using total DNA extracted from the root tissue of healthy plants.

The results obtained on 60 isolates of *P. graminis* from plants grown under controlled conditions and plants collected in the fields demonstrated a perfect concordance between the four molecular methods developed. Different associations between *P. g. temperata* and/or *P. g. tepida* with bymo- and/or furoviruses were obtained, depending on the tested soil and cereal in the bioassays (Table 1). Both *P. g. temperata* and *P. g. tepida* were isolated from the three soils analysed, but the frequency of detection varied according to the soil and the bait plant. In the plants collected in the fields, *P. g. temperata* was detected on barley plants collected at Gembloux and was found to be associated with BaYMV transmission. *P. g. tepida* was detected on wheat plants grown in Chambon-sur-Cisse and Flavion fields and associated with furoviruses and WSSMV infections. Furthermore, in the two latter fields both *P. g. temperata* and *P. g. tepida* were observed on two of the 10 wheat plants tested in each field. In addition, in the automatic immersion systems it was shown that *P. g. temperata* on barley is able to colonize wheat and that *P. g. tepida* from wheat also infects barley.

Table 1. Co-infections observed between furoviruses (F), WSSMV, BaYMV, *P. g. temperata* (*Pg temp*) and *P.g. tepida* (*Pg tep*), on barley and wheat plants grown in Chambon-sur-Cisse, Flavion and Gembloux soils, and the infection frequency.

Soil	Cereals	F	WSSMV	BaYMV	<i>Pg temp</i>	<i>Pg tep</i>	Frequency
Chambon-sur-Cisse	Barley	+	+	+	+	-	1/6
		+	+	-	+	-	2/6
		+	-	-	+	-	2/6
		+	-	-	+	+	1/6
	Wheat	+	+	-	-	+	5/10
		+	-	-	-	+	4/10
		+	-	-	+	+	1/10
	Flavion	Wheat	+	+	-	-	+
+			+	-	+	+	1/4
Gembloux	Barley	-	-	+	+	-	5/12
		+	-	+	+	-	3/12
		+	-	-	+	-	2/12
		-	+	-	+	-	2/12
	Wheat	+	+	-	-	+	2/5
		+	-	-	-	+	1/5
		-	+	-	-	+	1/5
		+	+	+	+	+	1/5

Discussion

RFLP analysis, nested and multiplex PCR and real-time PCR were successfully developed and used to detect, discriminate and specifically quantify *P. g. temperata* and *P. g. tepida*. It is the first time that these two *formae speciales* occurring in temperate areas could be quantified specifically by real-time PCR. This method was developed as a tool for evaluating the susceptibility to *P. g. temperata* and *P. g. tepida* by quantifying the vector population concentration in barley, rye and wheat cultivars. In addition, real-time PCR allows an estimation to be made of the infection frequency of *P. g. temperata* and *P. g. tepida*.

Our tests confirmed that both *P. g. temperata* and *P. g. tepida* could be isolated from the same soil and the same plant, but the former was found mainly on barley and the latter on wheat (Ward *et al.*, 2005). Depending on the soil and cereal species analysed, different co-infections of bymo- and/or furoviruses with *P. g. temperata* and/or *P. g. tepida* were observed on both barley and wheat plants, indicating a greater diversity of association between the three actors involved in mosaic diseases than expected. These results suggest a certain but not exclusive specialization of interactions between plant, *P. graminis formae speciales* and viruses because in most of the cases *P. g. temperata* was associated with BaYMV transmission on barley and *P. g. tepida* with furoviruses and WSSMV infections on wheat. On the basis of sequencing results, a different ribotype closely associated with *P. g. temperata* was isolated on rye. For the three soils analysed, the two *formae speciales* of *P. graminis* and the bymo- and furoviruses were detected in bait plants grown under controlled conditions. Therefore, even in the absence of obvious mosaic symptoms, the inoculum may be present in soils, indicating a potential risk of disease development. The environmental conditions as well as the choice of varieties cultivated may be determinants of mosaic expression.

Acknowledgements

This research was funded by the Ministère de la Région wallonne, Direction générale de l'Agriculture, Direction de la recherche. The authors are grateful to M. Bonnefoy (ARVALIS, France) and S. Steyer (CRA-W, Belgium) for providing the infested soils and plants.

References

- Altschul, S.F., Gish, W., Miller, W., Myers, E.W., and Lipman, D.J. (1990). Basic local alignment search tool. *J. Mol. Biol.* **215**, 403-410.
- Legrève, A., Delfosse, P., and Maraite, H. (2002). Phylogenetic analysis of *Polymyxa* species based on nuclear 5.8S and internal transcribed spacers ribosomal DNA sequences. *Mycological Research* **106**, 138-147.
- Legrève, A., Delfosse, P., Van Hese, V., Bragard, C., and Maraite, H. (2003). Broad-spectrum detection of *Polymyxa* species and form species by polymerase chain reaction. In "Proceedings of the fifth Symposium of the International Working Group on Plant Viruses with Fungal Vectors", 22-25 July 2002, IPS, Zurich, Switzerland (C.M. Rush, and U. Merz, Eds), pp.40-43. American Society of Sugar Beet Technologists, Denver, USA.
- Legrève, A., Delfosse, P., Vanpee, B., Goffin, A., and Maraite, H. (1998). Differences in temperature requirements between *Polymyxa* sp. of Indian origin and *Polymyxa graminis* and *Polymyxa betae* from temperate areas. *European Journal of Plant Pathology* **104**, 195-205.
- Vaïanopoulos, C., Legrève, A., Barbier, A., Steyer, S., Maraite, H., and Bragard, C. (2003). Detection of *Barley yellow mosaic virus* and *Barley mild mosaic virus* by RT-PCR on resistant barley cultivars. *Parasitica* **59**, 67-74.
- Vaïanopoulos, C., Legrève, A., Lorca, C., Moreau, V., Steyer, S., Maraite, H., and Bragard, C. (submitted). Widespread occurrence of *Wheat spindle streak mosaic virus* in Belgium. *Plant Dis.* submitted.
- Ward, E., Kanyuka, K., Motteram, J., Korniyukhin, D., and Adams, M.J. (2005). The use of conventional and quantitative real-time PCR assays for *Polymyxa graminis* to examine host plant resistance, inoculum levels and intraspecific variation. *New Phytologist* **165**, 875-885.

UK FIELD INVESTIGATIONS OF BEET NECROTIC YELLOW VEIN VIRUS CONTAINING RNA5

G.E. Budge¹; L.I. Ward¹ and C.M. Henry¹

¹Central Science Laboratory, Sand Hutton, York, N. Yorks, YO411LZ, UK

Summary

Isolates of *Beet necrotic yellow vein virus* (BNYVV) containing an additional RNA (RNA5) have been reported to cause severe yield reduction in BNYVV resistant sugar beet varieties. A field study was conducted over two seasons to investigate whether the resistance inferred by the Holly gene (Rz1) remained effective when grown on a field infected with BNYVV containing RNA5 in the UK. For the second season, a trial was also conducted on a site infected with A pathotype BNYVV. Sugar beet were harvested at three times through the growing season. For each plant, symptoms were scored, the presence of BNYVV determined by ELISA and root fresh weight measured. Nucleic acid was extracted from selected plants and the presence of RNA2 and RNA5 determined using real-time PCR assays. In both years, a higher proportion of plants from susceptible cultivar Roberta were infected with BNYVV than the resistant cultivar Rayo. In addition, reductions in total beet weight and % sugar were greater for Roberta than for Rayo for both years on the P site. A most probable number experiment revealed the inoculum levels on the P site were 20 times less than the A site. However, a larger number of Rayo plants were infected at low levels on the P site than on the A site. Similar levels of infection were seen in Roberta on both sites despite the large difference in soil inoculum levels. This suggests the RNA5 containing pathotype is more infectious than the A type to cultivars containing the Rz1 resistance gene. In addition on the P site, Rayo plants only became infected in the presence of RNA5, providing more evidence this RNA plays an essential role in infecting Rz1 containing cultivars.

Introduction

Three pathotypes of *Beet necrotic yellow vein virus* (BNYVV) exist worldwide. A and B pathotypes contain 4 RNA species. The P Pathotype, contains an additional RNA5 and is reported to be the most aggressive Pathotype of BNYVV. In Europe the P pathotype has been found in France (Koenig et al., 1997) and more recently the UK (Harju et al., 2002). To date there are only two known sites infected with the RNA5 in the UK, both located in Norfolk. The majority of current resistant sugar beet varieties include the Rz1 gene. Field trials were carried out to investigate the interaction of RNA5 with a cultivar containing Rz1.

Materials and Methods

Field trial 2003

Two sugar beet cultivars varying in reaction to BNYVV were selected. In order to take into account inoculum variability in the field, Roberta (BNYVV susceptible) and Rayo (partially resistant and containing Rz1 resistance gene) were drilled in strips across the infected patch. Each cultivar was drilled as alternate strips each containing 3 rows spaced 0.5 m apart. The trial was split into 3 uneven blocks. For each assessment, 368 random plants were sampled for each cultivar. The trial was sampled 3 times during the growing season. For each plant, leaf and root symptoms were scored and the presence of BNYVV determined using triple antibody sandwich (TAS) ELISA (Harju et al., 2005) and the fresh root weight determined. For each

cultivar nucleic acid was extracted from 75 plants from the most infected block, using a standard CTAB method. Presence of RNA2 and RNA5 was determined for each extract using real-time PCR assays as described by Harju et al. (2005). For the final assessment, cores (No. 4 borer) from 15 roots were collected and % sugar calculated for healthy and infected groups of each cultivar.

Field trials 2004

An additional trial site was chosen on land infected with the A pathotype of BNYVV and identical trials carried-out on this and the P Pathotype site. Both trials were set-up as previously described, except 220 samples were collected from each cultivar at each of three sampling points.

Analysis of trial data

All weight data were normalised using generalised linear models assuming a Gamma distribution with identity link function. Standard deviation and confidence intervals of percentage weight loss are calculated according to the formulas derived by Fieller (1940). Standard deviation and confidence intervals for percentage weight reduction are based on the large sample normal approximation and the variance formula for products of random variables according to Mood et al. (1974).

Quantitation of soil inoculum levels

Soil samples were collected from 100 sample points for each block after the final harvest in 2004. In addition, soil containing BNYVV P type was collected from Pithivier in France. Soil was air dried and passed through a 2 mm sieve prior to diluting 1 part soil in 2.5 parts sand through seven levels. Soil/sand mix was aliquotted into 60 ml module pots with 12 replicates per dilution, and two pregerminated Roberta bait plants placed in each module. Bait plants were grown in a temperature controlled glasshouse cubicle for six weeks prior to testing root material for the presence of BNYVV using TAS ELISA as previously described. Absorbance values above three times the negative control (healthy root material) were considered to be positive. BNYVV scores for each soil dilution were analysed using the DILUTION procedure of Genstat 6 and the most probable number (MPN) estimate for each soil sample calculated (Cochran, 1950).

Results

In 2003, infection rates increased for both varieties as the season progressed. Infection rates for Roberta remained far higher than those for Rayo. In the final assessment, 49.3% of Roberta and 10.5% of Rayo plants harvested from block 1 tested positive for BNYVV by ELISA. Infection rates for the final harvest on the P field in 2004 were similar to 2003, with 17.7% of Roberta and 9.6% of Rayo plants testing positive for BNYVV by TAS ELISA. The corresponding values for the A field were 25.9% for Roberta and 1.8% for Rayo. Differences between infection rates for Rayo and Roberta were statistically significant for all three trials.

Infection with BNYVV caused significant weight reductions in both Roberta and Rayo on the P site in 2003. No significant reductions were seen in Rayo at either site in 2004. In contrast, significant reductions were seen in Roberta at both the P and A sites. Total % weight reduction for each cultivar was calculated by taking the product of % infection and % weight loss. While a variance of this product can be derived, no formula is known for confidence intervals. Thus, bootstrap standard errors and confidence intervals have been calculated. In the final assessment for the P site in 2003 a significantly lower total weight reduction was recorded for

Rayo compared to Roberta. No significant reduction was found in Rayo at either site in 2004 but significant reductions were found at these sites in Roberta (Table 1).

Table 1. Total % weight reduction caused by BNYVV infection.

Variety/site	% total weight reduction	s.d.	95% confidence intervals	
			Lower	Upper
P site 2003				
<i>Roberta</i>	18.94	4.14	10.33	26.76
<i>Rayo</i>	3.44	1.44	0.73	6.39
P site 2004				
<i>Roberta</i>	9.44	1.82	5.99	13.13
<i>Rayo</i>	1.33	1.36	-1.44	3.93
A site 2004				
<i>Roberta</i>	10.47	1.73	7.08	13.92
<i>Rayo</i>	0.20	0.36	-0.45	0.95

Reductions in sugar content on the P site in 2003 were greater for cultivar Roberta (2.25%) than for Rayo (0.81%). In 2004 no reduction in % sugar content was seen in Rayo at either site. Corresponding reductions in Roberta were 1.5% and 1.9% respectively for the P and A sites.

The results of the MPN estimation of soil inoculum levels of BNYVV showed the A site had the highest level of inoculum with an MPN estimate of 58.3 (48.39,69.67) with the soil from the UK P site only having an MPN estimate of 3.2 (2.44, 4.21). Soil from Pithiver in France had an MPN estimate of 16.6 (11.17,23.64).

Analysis for RNA2 using real-time RT PCR revealed an increase in all % infection rates for both varieties in 2004 compared to the TAS ELISA results (Table 2).

Table 2. Percentage infection rates as determined using the RNA2 real-time RT PCR assay and TAS ELISA in 2004.

Variety/site	RNA2 assay	TAS ELISA
P site		
<i>Roberta</i>	57	20
<i>Rayo</i>	41	8
A site		
<i>Roberta</i>	81	30
<i>Rayo</i>	2	1

Discussion

A higher proportion of plants from cultivar Roberta were infected with BNYVV than Rayo. In addition, reductions in total beet weight and % sugar were greater for Roberta than for Rayo. Although significant differences in resistance behaviour were observed when Rayo and Roberta are grown on land infected with the UK P Pathotype, the inoculum levels were low compared to Pithivier in France. Despite much lower inoculum levels on the UK P site, more Rayo plants became infected than on the A site, suggesting the P Pathotype is more infectious to Rz1 containing cultivars than the A type.

Analysis using real-time RT PCR revealed a large number of Rayo positives at the P site in both 2003 and 2004. These were not detected using less sensitive TAS ELISA, therefore these are thought to represent low level infections. Further analysis of real-time PCR results showed RNA2 was never present in Rayo without the presence of RNA5, indicating the importance of RNA5 in the infection of resistant cultivars.

Future work will investigate how cultivars containing Rz1-Rz3 perform on land infected with higher levels of P Pathotype. Further analysis of real-time data from T1 and T2 will be completed to compare build-up of RNA2 and RNA5 through the season at the A and P sites.

We thank Janina Jones at RRes for the sugar analysis; our colleagues who assisted with the beet collection; and Carola Deppe for help with the statistical interpretation. Also we gratefully acknowledge the host farmers for their respective contributions. This work was carried out under Defra project number PH0188.

References

- Cochran WG (2004). Estimation of bacterial densities by means of the 'Most Probable Number'. *Biometrics* **6**, 105-116.
- Fieller, EC (1940). The Biological Standardization of Insulin." *Journal of the Royal Statistical Society* **7** (supplement): 1-64.
- Harju VA, Mumford RA, Blockley A, Boonham N, Clover GRG, Weekes R, and Henry CM (2002). Occurrence in the United Kingdom of Beet necrotic yellow vein virus isolates which contain RNA 5. *Plant Pathology* **51**, 811-811
- Harju VA, Skelton A, Clover GRG, Ratti C, Boonham N, Henry CM, and Mumford RA (2005). The use of real-time RT-PCR (TaqMan ®) and post-ELISA virus release for the detection of beet necrotic yellow vein virus types containing RNA 5 and its comparison with conventional RT-PCR. *Journal of Virological Methods* **123**, 73-80
- Koenig R, Haeberle AM, and Commandeur U (1997). Detection and characterization of a distinct type of beet necrotic yellow vein virus RNA 5 in a sugarbeet growing area in Europe. *Archives of Virology* **142**, 1499-1504
- Mood AM, Graybill FA and Boes DC. (1974). *Introduction to the Theory of Statistics* (3rd edition). New York: McGraw-Hill.

SOIL TREATMENT WITH CARBOFURAN MITIGATES PEANUT CLUMP VIRUS DISEASE INCIDENCE AND IS TOXIC TO THE VECTOR *POLYMYXA GRAMINIS*

P. Delfosse¹, F. Nguyen², A. M. Paridaens², C. Bragard², and A. Legrève²

¹ International Crops Research Institute for the Semi-Arid Tropics (ICRISAT), BP 12 404, Niamey, Niger, delfosse@pt.lu

² Unité de phytopathologie, Université catholique de Louvain, Croix du Sud, 2 bte 3, 1348 Louvain-la-Neuve, Belgium, legreve@fymy.ucl.ac.be, bragard@fymy.ucl.ac.be

Summary

Carbofuran (2,3-dihydro-2,2-dimethyl-7-benzofuranyl methylcarbamate) is primarily known as a systemic insecticide and nematicide with no phytotoxic action. In the eighties, it was shown to reduce the *Indian peanut clump virus* (IPCV) incidence on groundnut crops in India but its mode of action on the virus or its vector *Polymyxa graminis* remained unexplained. To confirm that carbofuran could also control *Peanut clump virus* (PCV) occurring in Africa, field trials were set up in 2003 and 2004 in the same experimental field of the ICRISAT farm at Sadoré, Niger in order to assess the residual effect of the treatment on the subsequent crop. In the treated plots, carbofuran was applied in the furrows @ 5 kg a.i./ha prior to sowing groundnut. In 2003 the results indicated a significant reduction in PCV incidence from 56.2% in the control to 33.8% in the carbofuran treated plots ($P=0.007$). In 2004, PCV incidence was significantly reduced from 81.6% in the control to 71.1% in the plots treated in 2003 ($P=0.048$) and 58.8% in the plots treated the same year ($P<0.020$). This reduction induced significant increases in pod yield for both years. The effect of carbofuran on the vector was furthermore analysed under controlled conditions at UCL in Belgium where the infection level of bait plants by *P. graminis* was measured by real-time quantitative PCR. A significant reduction ($P<0.001$) of *P. graminis* DNA in plants grown on soil originated from Niger and treated with carbofuran was recorded. Carbofuran also tended to reduce *P. graminis* DNA for plants grown on sterile sand and inoculated with a high number of sporosori. The effectiveness of carbofuran treatments on station and on farm is discussed.

Introduction

Peanut clump virus (PCV), a member of the Pecluviruses, is soil-borne and causes significant yield losses in groundnut crops in West Africa. It is transmitted by *Polymyxa graminis* (Legrève *et al.*, 2004) and by seed of at least groundnut and pearl millet (Otto *et al.*, this volume). The *Indian peanut clump virus* (IPCV) is the causal agent of a similar disease in India and is also transmitted by *P. graminis* and seed of groundnut, maize, pearl millet, finger millet, foxtail millet, and wheat (Delfosse *et al.*, 2002). In preliminary studies conducted in West Africa and India in the 70s and 80s, PCV and IPCV were thought to be transmitted by nematodes and treatments with nematicides significantly reduced the disease incidence in field experiments (Germany & Dhery, 1973, Dhery *et al.*, 1975, Reddy *et al.*, 1988). However treatments with these chemicals were considered hazardous or not economical for small-scale farming and today nematodes are no longer considered to play a direct role in the transmission of pecluviruses. PCV in West Africa occurs with high incidence in research stations in Senegal, Mali, Burkina Faso and Niger (Delfosse *et al.*, unpublished). This represents a high risk of spreading the disease on large distances through seed of mainly groundnut and pearl millet, which are undergoing breeding programs and multiplication schemes on these stations. The experiments with carbofuran presented in this paper were designed to assess if the chemical has a direct action on the vector *P. graminis*, if it can significantly reduce PCV incidence in groundnut, and to measure the increase in yield that can be achieved with such treatment in seed multiplication schemes.

Materials and Methods

Field experiments. The experimental design consisted of 8 randomized blocks with 4 treatments applied in 9m² elementary plots. In 2003, the two treatments of interest for this paper were: carbofuran (Furadan 5G, 5% a.i.) applied in the furrows @ 10 g Furadan/m² prior to sowing and the control. The additional treatments presented here only for clarity of the experimental design were: application of diamonium phosphate (DAP) and seed priming. In 2004, the same experimental plots were used to assess the residual effect of carbofuran and DAP in the subsequent crop (plots treated in 2003). Carbofuran (2004 treatment) was applied in plots used for seed priming in 2003 and the control plots were those used in 2003. After a light soil preparation to incorporate a basal application of NPK (15-15-15) @ 100 kg/ha, the groundnut cv. 55-437 (growth cycle of 90 days) was sown at 10 cm depth, 15 cm intervals in rows 40 cm apart, on July 9, 2003 and on June 10, 2004. The crops were harvested on Oct. 13, 2003 and on Sept. 21, 2004. The yield parameters observed were the dry pod and dry haulm weights. The PCV incidence was assessed by ELISA tests on leaves approximately 50 days after sowing. Leaf samples were collected from plants (10 plants in 2003 and 20 plants in 2004) located in a 1x1m square frame centrally positioned in each plot. Additionally in 2003, the effect of carbofuran on the total nematode population was also investigated.

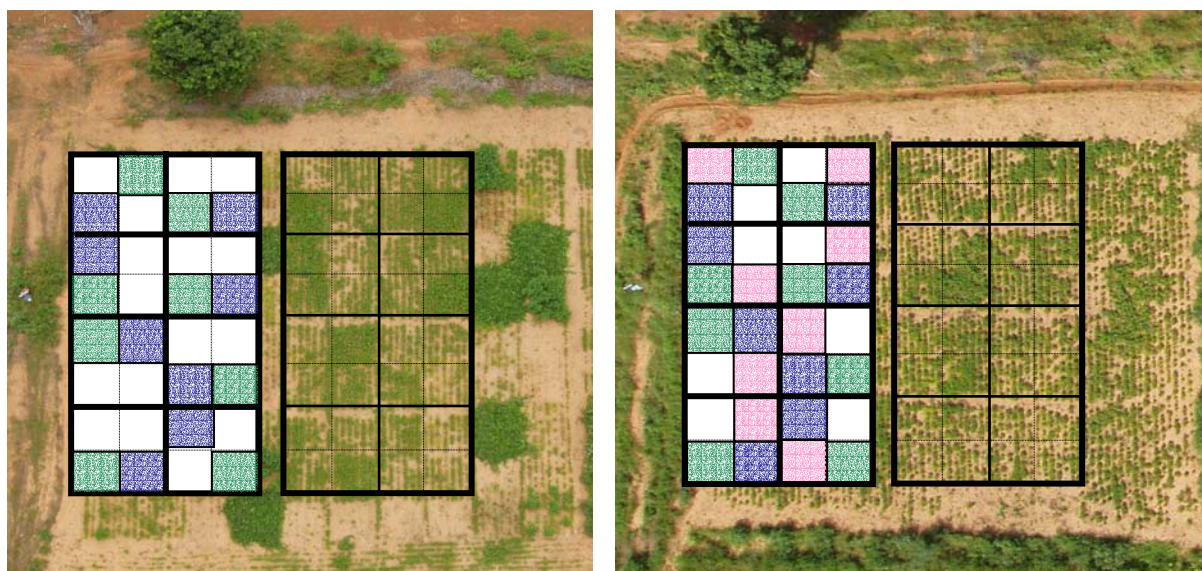

Figure 1: Aerial photograph of the experimental field taken with the help of a zeppelin balloon and a remote controlled digital camera in September 2003 (left) and late August 2004 (right) approximately 3 months after sowing (ICRISAT-Farm, Sadoré, Niger). For each season, the color symbols are kept to the left side of the field and the treatments were: carbofuran applied in 2003 (blue), carbofuran applied in 2004 (pink), and the control (green).

Laboratory experiments. At UCL, Belgium, the effect of carbofuran (0.81mg a.i./plants) on *P. graminis* efficiency to invade the host root system was assessed by measuring the quantity of *P. graminis* DNA present in the roots of bait plants (pearl millet cv. ICMV-IS-94906). One set of plants was grown on sterile sand inoculated with an isolate from Niger (*P. graminis* Ni-1, Sadoré 2002) using approximately 10 000 sporosori, 3 days after sowing. The second set of plants tested was grown on a 1:1 mixture of sterile sand and naturally infested soil collected in September 2003 in a field cropped with sorghum and pearl millet during the 2003 rainy season and located on the ICRISAT-farm. The soil was air dried and stored at room temperature for about 5 months before use. Bait plants were grown in 500 ml pots (5 plants/pot and 4pots/treatment) for 48 days in a growth chamber maintained at 30°C during the day and 25°C

during the night with a 12h photoperiod. After the growing period, the roots were collected and washed free of soil/sand particles. For each pot the 5 root systems were cut in small fragments, thoroughly mixed and a 100 mg composite sample was used for DNA extraction using the FastDNA kit (Qbiogene Inc.). The relative quantity of DNA (Rel DNA qty) was estimated by real-time PCR with SYBR green 1 using the primers Pgr2 (GGGTTTTTTGTTGCGAAATGTC) and Psp2rev (AGGGCTCTCGAAAGCGCAA). The results were compared statistically in ANOVA after a Log transformation to fit the criteria of homogenous variance (Dieryck *et al.*, submitted).

Results and Discussion

Field experiments. Treating the soil with carbofuran had a startling effect on the groundnut aerial growth in 2003 while the effect was not as obvious for 2004 (Fig. 1). For the whole field the crop appeared much more developed in 2003 than in 2004. These aerial observations were confirmed by ground ones. In 2003, a significant reduction in PCV incidence from 56.2% in the control to 33.8% in the carbofuran treated plots ($P=0.007$) was observed. In 2004, PCV incidence was significantly reduced from 81.6% in the control to 71.1% in the plots treated in 2003 ($P=0.048$) and 58.8% in the plots treated the same year ($P<0.020$). In 2003, the nematode population was significantly reduced from 285 nematodes/100ml of soil in the control plots to 144 nematodes/100ml in the treated plot ($P<0.001$). These reductions in PCV and nematode incidences resulted in significant increases in pod yield for both the years for the application prior to sowing the crop (Table 1).

Table 1. Effect of carbofuran (5kg a.i./ha) on the groundnut yield components for the 2003 and 2004 rainy season, ICRISAT Farm, Sadoré, Niger.

	Yield components (kg/ha)		
	Haulms	Pods	Total Biomass
2003			
Control	999	1052	2051
Fu 2003	1336	1563	2899
SED (<i>P-value</i>)	108 (0.017)	81 (0.001)	168 (0.002)
2004			
Control	1451	988	2439
Fu 2003	1304	971	2275
Fu 2004	1834	1269	3103
SED (<i>P-value</i>)	209 (0.062)	81 (0.002)	279 (0.024)

Fu 2003: carbofuran applied in the seed furrow in 2003; Fu 2004: carbofuran applied in the seed furrow in 2004; Control: untreated plots identical for both seasons; SED: Standard error of difference of means; *P-value*: from ANOVA with blocking (8 rep)

When comparing the two seasons in the untreated plots, a much higher disease incidence was observed in 2004 (81.6%) than in 2003 (56.2%) and during the groundnut growth cycle rainfall was relatively low for both the years (344 mm in July-Oct., 2003) but higher for 2004 (446 mm in June-Sept.). The sum of rains that occurred prior to the sowing of the crop reached 188 mm in 2003 and 107 mm in 2004. From experiments conducted in India, it was apparent that high rainfalls during the early stage of crop development were conducive for high disease incidence whereas rains occurring prior to the sowing usually resulted in lower disease incidence. These observations reinforced the statement on the importance of the distribution and quantity of rainfall on PCV disease incidence (Delfosse *et al.*, 2002).

Laboratory experiments: The analysis of infection level of bait plants by *P. graminis* measured by real-time quantitative PCR indicated a 1000 times reduction ($P<0.001$) of the *P. graminis* Rel DNA qty in plants grown on naturally infested soil and treated with carbofuran (1.2×10^{-8}) compared to the untreated plants (1.1×10^{-5}). The reduction observed for the treated plants

grown on sterile sand and inoculated with a very high concentration of sporosori (Rel DNA qty= 4.3×10^{-5}) compared to the untreated ones (Rel DNA qty= 2.7×10^{-4}) reached a factor of about 6 but the high variability in the response did not yield significant difference between the two treatments ($P=0.087$). It is interesting to stress that for the untreated plants, the Rel DNA qty in the inoculated plants was much higher than that observed for the plants grown on naturally infested soil ($P<0.001$) suggesting that the 1:1 soil:sand mixture contained much less viable sporosori than the inoculation dose.

In previous reports, the application of carbofuran at 1.6 kg a.i./ha did not reduce PCV incidence whereas DBCP (1.2 di-bromo-3-chloropropane), now a banned chemical, almost completely controlled the disease (Dhery *et al.*, 1975). The results of the present experiments confirmed that carbofuran applied at the nematocidal dose of 5 kg a.i./ha, recommended for nurseries, can mitigate PCV disease incidence, and increase groundnut yield most probably as a result of a combined control of both *P. graminis* and nematode populations. Attempts to acquire/transmit IPCV by nematodes were unsuccessful (Reddy *et al.*, 1988) but these worms can nevertheless be suspected to facilitate or stimulate infection by the actual vector, *P. graminis*, through the release of stimuli by the wounded roots and consequently favor virus transmission (Germany & Dhery, 1973). The use of carbofuran is nevertheless not recommendable and probably not cost effective for small scale farming in Niger since it is an acute poison, and farmers do not have access to either proper protective clothing nor to training on the safe use of such chemicals. On the other hand, carbofuran can be helpful for on-station breeding and cultivar evaluation trials where PCV can interfere with groundnut, millet and sorghum yields (Delfosse *et al.*, unpublished). Its use in seed multiplication schemes can reduce PCV incidence and consequently the rate of virus-infected seed present in seed lots.

The authors are thankful to DGCD-Brussels for funding this research and to S. Adamou, H. Dodo, A. Mounkaila, Z. Soumana (ICRISAT-Niger) and V. Van Hese (UCL-Belgium) for technical assistance.

References

- Delfosse P., Reddy A.S., Thirumala Devi K., Legrève A., Risopoulos J., Doucet D., Shoba Devi P., Maraite H., and Reddy D. V. R. (2002) Dynamics of *Polymyxa graminis* and *Indian peanut clump Virus* (IPCV) infection on various monocotyledonous crops and groundnut during the rainy season. *Plant Path* **51**, 546-560.
- Dhery M, Germani G, Giard A., (1975). Résultats de traitements nématicides contre la chlorose et le rabougrissement en Haute-Volta. *Cahiers ORSTOM, Série Biologie* **3**, 161–7.
- Dieryck B, Delfosse P, Otto G, Sauvenier X, Bragard C and Legrève A. (2005) Peanut clump virus and *Polymyxa graminis* interactions with pearl millet and sorghum. *Parasitica: in press*.
- Germany G. & Dhery M. (1973) Observations et expérimentations concernant le rôle des nématodes dans deux affections de l'arachide en Haute Volta: la "chlorose" et le "clump". *Oléagineux*, 28e année, no 5: 235-242.
- Legrève A., Delfosse P., Vankeerberghen T., Van Hese V., and Maraite H. (2004). *Polymyxa graminis*, a promiscuous vector of viruses on crops in tropical areas. *Meded. Zin. K. Acad. Overzeese Wet. / Bull Seanc Acad. R. Sci. Outre-Mer* **50**, 115-126.
- Reddy, D. V. R., Nolt, B. L., Hobbs, H. A., Reddy, A. S., Rajeshwari, R., Rao, A. S., Reddy, D. D. R. & McDonald, D. (1988). Clump virus in India: isolates, host range, transmission and management. - In : Cooper, J. I. & Asher, M. J. C. (eds) , *Developments in Applied Biology II. Viruses with Fungal Vectors*, Association of Applied Biologists, Wellesbourne, UK, pp. 239–246.

THE ROLE OF CLIMATE AND ALTERNATIVE HOSTS IN THE EPIDEMIOLOGY OF RHIZOMANIA

Anne Legrève , Jean-François Schmit, Claude Bragard and Henri Maraite

Unité de phytopathologie, Université catholique de Louvain, Croix du Sud 2/3, 1348 Louvain-la-Neuve, Belgium (legreve@fymy.ucl.ac.be, jean-francois.schmit@afsca.be)

Summary

After its localised detection on coastal plain soils in the Polders, rhizomania, a sugar beet soil-borne disease caused by *Beet necrotic yellow vein virus* (BNYVV) and transmitted by the plasmodiophorid *Polymyxa betae*, became widespread between 1984 and 2002 in the main sugar beet growing areas on the plateau in Belgium. The influence of meteorological factors and alternative hosts in the understanding of this dynamic was analysed. The infection of sugar beet by *P. betae* was monitored in six fields, together with rainfall, soil water content and temperature. In the two fields in the Polders, characterized by a water table close to the surface and by a slightly milder climate compared with the other locations on the plateau, one single rainy period after the sowing was enough to initiate the infection. In the other fields, two rainy periods were usually necessary before *P. betae* was detected in the roots. The need for near-saturated soil moisture conditions for the preparation of resting spores germination and the release of zoospores explains the difference in infection earliness and progression. Mild and rainy spring seasons in recent years could have favored the multiplication of viruliferous inoculum. Possible alternative hosts for *P. betae* and BNYVV were identified by growing 64 plant species on rhizomania-infested soil. Twenty-nine of them, belonging to Amaranthaceae, Asteraceae, Brassicaceae, Caryophyllaceae, Chenopodiaceae, Papaveraceae, Poaceae and Urticaceae, proved to be infected by both the virus and its vector, using RT-PCR. Back transmission to sugar beet was shown in seven species belonging to Caryophyllaceae, Chenopodiaceae and Poaceae.

Introduction

Rhizomania of sugar beet, caused by *Beet necrotic yellow vein virus* and transmitted by the plasmodiophorid *Polymyxa betae*, was first reported in Belgium in 1984 in the Polders. It was confined to that area for some years, but after 1995 it spread to the main sugar beet growing areas (Wauters, 2004). A first hypothesis was that this spread could be related to an increase of the inoculum potential (IP) of the viruliferous *P. betae*. An epidemiological study performed in the 1990–91 growing seasons on the dynamics of sugar beet infection by *P. betae* and BNYVV in six fields in Belgium in parallel with the IP of *P. betae* in soils and meteorological conditions highlighted particular conditions influencing root infection. The study results are reported here and indicate that the meteorological conditions of the past 15 years have probably contributed to the increasing incidence of rhizomania. A second hypothesis is that the source of inoculum may be a factor. In the second part of this study, the role of alternative hosts of *P. betae* and BNYVV as sources of inoculum was investigated.

Materials and Methods

Influence of edaphical and meteorological conditions on *P. betae* and BNYVV infection under natural conditions. Six experimental fields (three in 1990 and three in 1991) were selected in the sugar beet growing areas in Belgium. Soil samples were collected before the sugar beet was sown; physical and chemical properties were characterized by the Service pédologique de

Belgique (Leuven, Belgium) and the inoculum potential of *P. betae* was quantified as described by Goffart *et al.* (1989). After sowing, the plants were sampled at regular intervals. Half of each root was stained in cotton blue lactophenol and observed under a microscope to assess *P. betae* infection. The presence of BNYVV was evaluated in the other part of each root by ELISA using a Sanofi kit (France). During the growing season, the air and soil temperatures, the rainfall and the soil moisture were measured in each field using automatic recording systems, Omnidata-Datapod DP 230 with pluviometer GS171 and temperature probe TP10V and Omnidata-Datapod DP222 with resistive block SM897 and temperature probe TP10V.

Host range and alternative hosts of *P. betae* and BNYVV. Plant species from 21 families were sown separately (individually) on rhizomania-infested soils collected in Belgium at Hamme-Mille and Sart-Messire-Guillaume in 2000 and diluted in sand (1/8; v/v). The plants were grown at 25°C (day) and 22°C (night) with a 16h photoperiod, and were watered regularly with a Hoagland nutrient solution. After seven weeks, the roots were removed from the soil and rinsed with water. The presence of BNYVV was assessed by DAS ELISA using a Biorad kit (France) and *P. betae* detection was done by observation under the microscope. The presence of the virus and its vector was also tested by multiplex RT-PCR using the method described by Meunier *et al.* (2003). The infection of plant species by BNYVV or *P. betae* was assessed again in a second test. The dried roots of plant species infected by both agents were used as inoculum for a back transmission test to sugar beet. They were cut into small fragments and mixed with sterilized sand. Sugar beet var. Cadyx was sown and, after seven weeks growth, the infection by *P. betae* and BNYVV was assessed using the methods described above.

Results and discussion

The dynamics of the infection of *P. betae* and BNYVV in three fields in parallel with the local meteorological conditions are shown in Fig. 1. In the epidemiological study performed in 1990, the sugar beet was sown in the second half of March. The first infection by *P. betae* was detected in the three experimental fields at the beginning of May, after two weeks of rainfall (~40 mm). *P. betae* was detected in 75% of plants at Dhuy and Doel, and in only 20% at Heron. This difference may be related to the IP, which was much lower in the soil at Heron than in the other two fields (Table 1). A second phase of infection occurred after the resumption of the rain at the beginning of June. In the half of August, the intensity of root infection was greater at Doel than at Dhuy or Heron. This observation was related to the high IP and to the higher rainfall in June and July (from 20 May to 30 July: 152 mm of rain at Doel, 111 mm at Dhuy and 131 mm at Heron).

Fig. 1. Dynamic of *P. betae* (▲) and BNYVV (■) infection (%) on sugar beet in 3 fields, at Doel in 1990 and at Doel and Warcoing in 1991 (left axis), in parallel with rain in mm (histogram) and mean soil temperature in °C (X)(right axis).

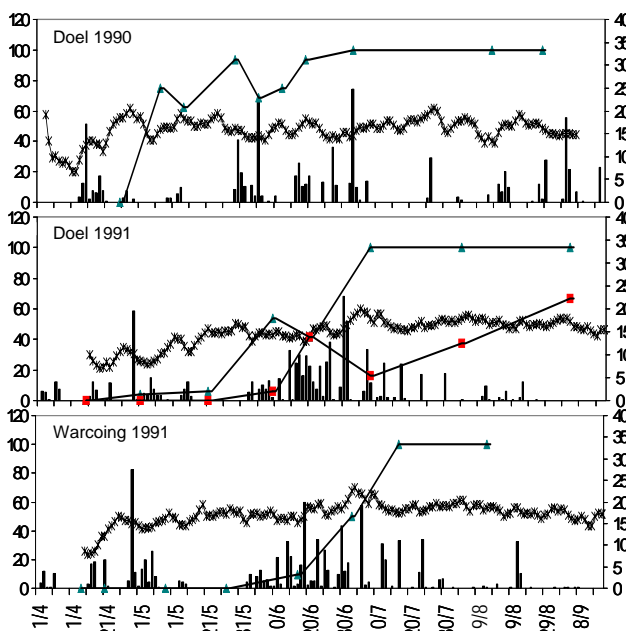

Table 1. Characteristics of soils in experimental fields, infection potential of *P. betae* (IP, in infectious unit per gram of soil), area under infection progression curve (AIPC) (Shaner and Finney, 1977) and AIPC cumulated with intensity of root infection (AIDPC)

Location, year	Soil pH	IP	Texture	AIPC*	AIDPC*
Doel, 1990	8.0	44.8	silty clay	9223	17797
Dhuy, 1990	8.3	21.5	light silt	6959	7126
Héron, 1990	6.6	0.9	heavy silt	3381	2778
Bombaye, 1991	7.1	3.2	heavy silt	4843	4759
Doel, 1991	7.8	7.3	heavy sandy silt	8416	17559
Warcoing, 1991	7.6	2.3	heavy sandy silt	7833	14651

AIPC = $\sum_{i=0}^{n-1} [(Y_{i+1} + Y_i)/2] [X_{i+1} - X_i]$ and AIDPC = $\sum_{i=0}^{n-1} [(Y_{i+1} + Y_i)/2] [X_{i+1} - X_i] [ID_i]$ and with Y_i = percentage of infection, X_i = time (in days) and ID_i = infection degree at the i th observation and n = total number of observations. ID: 1 = <5% infected rootlets; 2 = 5–10%, 3 = 10–40%; and 4 = >40%.* to mid August in 1990, to September in 1991

moisture conditions that are favorable to the preparation of germination of sporosori leading to *P. betae* infection after one rainfall period in the presence of young sugar beet roots. At Bombaye and Warcoing, two rainy periods were required: the first for the resting spore germination and the second for the releasing of zoospores. During that year, the infection rate increased at the end of June, especially at Doel and Warcoing where the rainfall was greater than at Bombaye (204 mm and 194 mm at Doel and Warcoing, 135 mm Bombaye, in June and July). Infection by BNYVV was observed only at Doel in 1991. The BNYVV infection progressed as the infection by *P. betae* progressed, but with a slight delay. These observations indicate that the infection increases in the roots when the soil temperature approaches 20°C and when rainfall is abundant. The increase in temperature and the occurrence of rainy spring and summer seasons in the recent years have thus probably been conducive to an increase in the inoculum in soils.

The involvement of alternative hosts as a source of inoculum was investigated in a host range study on 64 plant species. *Polymyxa betae* and BNYVV were both detected by RT-PCR in 29 species belonging to Amaranthaceae, Asteraceae, Brassicaceae, Caryophyllaceae, Chenopodiaceae, Papaveraceae, Poaceae and Urticaceae. *Polymyxa betae* was observed in 17 of these species, while the virus was detected by ELISA in only 15 of them (Table 2). The back inoculation test of both BNYVV and *P. betae* from these species to sugar beet were positive for the Chenopodiaceae (*Atriplex hortensis*, *Beta vulgaris*, *Chenopodium polyspermum* and *Spinacia oleracea*), the Caryophyllaceae (*Silene alba* and *S. noctiflora*) and two Poaceae (*Apera spica-venti* and *Poa pratensis*). These results demonstrated that plant species of several families, such as Poaceae, are unexpected hosts of both *P. betae* and BNYVV and may act as a source of inoculum for sugar beet infection. Furthermore, they allow a mixed infection of furo- and bymovirus. In addition to the co-detection of *P. betae* and BNYVV, the rhizomania vector was also detected by RT-PCR in five other species in the Apiaceae (*Aethusa cynapium* L.), the Asteraceae (*Achillea millefolium* L. and *Anthemis arvensis* L.), the Poaceae (*Lolium perenne* L.) and the Solanaceae (*Solanum nigrum* L.). The virus was detected by RT-PCR in five species in the Convolvulaceae (*Convolvulus arvensis* L.), the Rubiaceae (*Galium aparine* L.) and the Solanaceae (*Capsicum annuum* L., *Datura stramonium* L. and *Lycopersicon esculentum* Mill.).

Neither BNYVV nor *P. betae* were detected in the Apiaceae species *Daucus carota* L. and *Pastinaca sativa* L., the Asteraceae species *Arctium minus* L., *Cirsium arvense* (L) Scop., *Sonchus oleraceus* L., *Taraxacum officinale* (L.) Weber, *Centaurea cyanus* L. and *Lapsana communis* L., the Brassicaceae species *Raphanus sativus* L. and *Sinapis arvensis* L., the Cucurbitaceae species *Cucumis sativus* L., the Euphorbiaceae species *Euphorbia helioscopia* L. and *Mercurialis annua* L., the Fabaceae species *Pisum sativum* L., the Geraniaceae species

In 1991, sugar beets were sown at the end of March. The first infection was observed at the beginning of May at Doel, but only in about mid-June at Bombaye and Warcoing. The low soil temperature (only 15°C from the end of May at Doel and Bombaye) and the low IP (Table 1) may explain the delay in infection in comparison with 1990. The greater levels of infection at Doel compared with the other areas in Belgium had been observed previously (Goffart, unpublished data). The water table close to the surface and the clay texture of the soil in the Polders ensure soil

Geranium molle L., the Lamiaceae species *Galeopsis tetrahit* L., the Malvaceae species *Malva neglecta* Wallr, the Plantaginaceae species *Plantago lanceolata* L. and *Plantago major* L., the Poaceae species *Alopecurus myosuroides* Huds. and *Echinochloa crus-galli* (L.) P. Beauv, the Polygonaceae species *Polygonum persicaria* L., *Rumex acetosa* L. and *R. obtusifolius* L. or the Portulacaceae species *Portulaca oleracea* L.

These assays therefore demonstrated that the host ranges of *Polymyxa betae* and BNYVV are wider than previously known and several families hitherto unsuspected, including Poaceae, may be involved in the epidemiology of rhizomania.

Acknowledgements

The authors wish to thank the Institut de recherche scientifique dans l'industrie et l'agriculture and the Direction générale de l'agriculture du Ministère de la region wallonne for funding the research.

Table 2. Results of the detection of BNYVV by ELISA and of *P. betae* by microscopic observation in plant species found to be infected by BNYVV and *P. betae* by RT-PCR, and of re-inoculation test to *B. vulgaris*

Family	Species	<i>P. betae</i> microscopy	BNYVV ELISA	<i>B. vulgaris</i> inoculation
Amaranthaceae	<i>Amaranthus retroflexus</i> L.	+	-?	-
Amaranthaceae	<i>Gomphrena globosa</i> L.	-	+	-
Asteraceae	<i>Chrysanthemum segetum</i> L.	-	-	nt
Brassicaceae	<i>Capsella bursa-pastoris</i> (L.) Med.	-	-	-
Brassicaceae	<i>Thlaspi arvense</i> L.	-	-	-
Caryophyllaceae	<i>Silene alba</i> (Mill) E.H.L. Krause	+	+	+
Caryophyllaceae	<i>Silene noctiflora</i> L.	+	-	+
Caryophyllaceae	<i>Stellaria media</i> Sibth.	-	-	+
Caryophyllaceae	<i>Stellaria graminea</i> L.	-	+	nt
Chenopodiaceae	<i>Atriplex halimus</i> L.	+	+	nt
Chenopodiaceae	<i>Atriplex hortensis</i> L.	+	+	+
Chenopodiaceae	<i>Atriplex undulata</i> D. Dietr.	+	+	nt
Chenopodiaceae	<i>Chenopodium album</i> L.	+	+	nt
Chenopodiaceae	<i>Chenopodium bonus-henricus</i> L.	+	+	nt
Chenopodiaceae	<i>Chenopodium murale</i> L.	+	+	nt
Chenopodiaceae	<i>Chenopodium polyspermum</i> L.	+	+	+
Chenopodiaceae	<i>Chenopodium quinoa</i> Willd.	+	+	nt
Chenopodiaceae	<i>Chenopodium rubrum</i> L.	+	+	nt
Chenopodiaceae	<i>Chenopodium vulvaria</i> L.	+	+	nt
Chenopodiaceae	<i>Chenopodium amaranticolor</i> L.	+	-	nt
Chenopodiaceae	<i>Beta vulgaris</i> L.	+	+	nt
Chenopodiaceae	<i>Spinacia oleracea</i> L.	+	+	+
Papaveraceae	<i>Papaver rhoeas</i> L.	+	-	<i>P. betae</i>
Poaceae	<i>Hordeum vulgare</i> L.	-	-	-
Poaceae	<i>Poa pratensis</i> L.	-	-	+
Poaceae	<i>Apera spica-venti</i> (L.) P. Beauv.	-	-	+
Poaceae	<i>Digitalia sanguinalis</i> (L.) Scop	-	-	-
Poaceae	<i>Elymus repens</i> (L.) Goud	-	-	nt
Urticaceae	<i>Urtica urens</i> L.	-	-	nt

* nt : not tested

References

- Goffart, J.P., Horta, V. & Maraite, H. (1989). Inoculum potential and host range of *Polymyxa betae* and beet necrotic yellow vein furovirus. *EPPO Bulletin* **19**: 517-525.
- Meunier, A., Schmit, J.F., Stas, A., Kutluk, N. & Bragard, C. (2003). Multiplex Reverse Transcription-PCR for Simultaneous Detection of *Beet Necrotic Yellow Vein Virus*, *Beet Soilborne Virus*, and *Beet Virus Q* and Their Vector *Polymyxa betae* KESKIN on Sugar Beet. *Appl. Environ. Microbiol.* **69**: 2356-2360.
- Meunier, A., Schmit, J.F., Stas, A., Marlier, A., Wauters, A., Steyer, S. & Bragard C. (2000). The status of rhizomania in Belgium. *Parasitica* 2000, **56**: 85-95.
- Shaner, G. & Finney, R. E., (1977). The effect of nitrogen fertilization on the expression of slow-mildewing resistance in Knox wheat. *Phytopathology* **67**, 1051-1056.
- Wauters, 2004. Explosion de la rhizomania en 2004 : plus de 50% de champs contaminés ? Le Betteravier, Septembre 2004, 7-9.

SURVEY FOR *BEET NECROTIC YELLOW VEIN VIRUS* AND *POLYMYXA BETAE* KESKIN IN MARVDASHT, FARS PROVINCE OF IRAN

M.R.Moosavi¹ and M. Nekoiezadeh²

¹Plant Pathology Department, Islamic Azad University, Marvdasht Branch, Iran
²Private laboratory, Shiraz, Iran

Summary

During the summer of 2004, a survey was conducted to determine the incidence and distribution of *Beet necrotic yellow vein virus* (BNYVV) and its vector (*Polymyxa betae* Keskin) in the city of Marvdasht, Fars province of Iran, where about 80,488 tones of sugar beet was produced annually. A total of 353 root samples were collected randomly from 16 sugar beet fields (21-23 samples in each field) as well as 124 samples from plants showing rhizomania associated symptoms of xylem necrosis, root madness, lateral root proliferation, narrowed leaf laminae, petiole elongation, upright position of leaves, chlorosis and yellowing (7-9 samples in each field). The presence of BNYVV in the samples was tested by triple-antibody sandwich enzyme-linked immunosorbent assay (TAS-ELISA) using the specific antisera against BNYVV (Adgen diagnostic, UK). BNYVV was serologically detected in 48.2% and 81.0% of randomly and symptomatically collected samples, respectively. Root beard extract that had tested positive for BNYVV in ELISA tests were mechanically inoculated on indicator host plants, *Chenopodium quinoa*, which resulted in producing chlorotic followed by necrotic lesions. Reverse transcription followed by the polymerase chain reaction (RT-PCR) using specific primers for BNYVV RNA 1 to 4 confirmed the presence of BNYVV in the samples. In these reactions, the expected DNA fragment sizes of approximately 500 bp, 430 bp, 860 bp, and 600 bp were amplified. The samples also were tested by PCR for evaluation of the presence of *P. betae* using the specific primers (upstream primer: 5'-CAAACGCCTGAAATCATCTAAC-3' and downstream: 5'-GATGGCCCAATTCCTTACAC -3') that led to the amplification of an expected DNA fragment of approximately 170 bp in positive samples. This vector was found in 94% of the fields surveyed. Our results indicated widespread occurrence of BNYVV and its vector *P. betae* in the city of Marvdasht, one of the main areas for sugar beet production in Iran.

Introduction

Beet necrotic yellow vein virus (BNYVV; family *Benyvirus*) is a positive-stranded RNA virus with rod-shaped virions and an unusual multi-component genome. BNYVV is transmitted by the soil-borne plasmodiophoromycete fungus *Polymyxa beta* and is responsible for rhizomania disease of sugar beet, which is characterized by extensive rootlet proliferation from the main taproot and other abnormalities. (Dunoyer *et al.*, 2002; Tamada, 1999).

Sugar beet is one of the most important crops in Iran, which cultivated 186,000 ha with about 30 ton/ha yield in 2001 (FAO, 2001). BNYVV was previously once reported in sugar beet fields of the Fars province of Iran (Izadpanah *et al.*, 1996). In the present work, the distribution and relative incidence of *P. betae* and BNYVV were evaluated in the city of Marvdasht by using serological and molecular assays, as well as host range studies.

Materials and Methods

A total of 353 root samples were collected randomly from 16 sugar beet fields (21-23 samples in each field) as well as 124 samples from plants showing rhizomania associated symptoms (7-9 samples in each field). TAS-ELISA was done according to Henry et al., (1992) by using BNYVV-specific antibodies purchased from Adgen diagnostics (UK) according to the manufacturer's instructions.

Each sample with positive reaction in ELISA was grounded with sterilized mortar and pestle in 0.05 M sodium phosphate buffer containing 1% 2-mercaptoethanol, pH 7.0. Each root extract was mechanically inoculated on at least three *Chenopodium quinoa* plants.

Four pairs of primers for amplifying regions of BNYVV RNA1 to 4 were synthesized by MWG-Biotech Co. (Germany). The primers used in this study included, V1: 5'-GCATTTTTGTGAATACCAGG-3' and C1: 5'-GTACCACATAATCAAG AACC-3' (RNA1), V2: 5'-GTGAACTAT AATTTTCCGAT-3' and C2: 5'-ACTCC ACGTGAATTTAAAATC-3' (RNA2), V3:5'-GTTGTTGTGTTTTCTGATCA-3' and C3: 5'-ACCGTGAAATCACGTGT AGT-3' (RNA3), and, V4: 5'-GGTGCT TTCTTAATGCCCG-3' and C4: 5'-AA CGAGCCCGTTAATACAAT-3' (RNA4) The pairs of primers used can amplify fragments of about 500 bp, 430 bp, 860 bp and 600 bp, respectively (Koenig et al., 1995).

For detection of *P. betae* a pair of primers were designed and synthesized. It is including upstream, 5'-CAAACGCCTGAAATCATCTAAC-3' and downstream primer, 5'-GATGGCCCAATTCCTTACAC-3' which are used in PCR for root beard extracts (Meunier et al., 2003).

Results and Discussion

Molecular data obtained from PCR of root beard extracts revealed the widespread occurrence of *P. betae* in the Marvdasht region. This vector was found in 94% of the fields surveyed which show the potential of this disease for infecting beet farms in Fars province. Serological assays indicated the presence of BNYVV in 48.2% (170) of the randomly collected samples. Moreover, almost 81.0% of 124 symptomatic plants tested positive with BNYVV-specific antibodies used. These findings suggest that the virus is largely responsible for viral diseases of sugar beets in the Fars province of Iran.

Mechanical inoculation of *Chenopodium quinoa* resulted in producing chlorotic followed by necrotic lesions. Necrotic local lesions were similar to those of Richards (1991), and biologically confirmed the presence of BNYVV.

Fig.1 shows agarose gel electrophoresis of RT-PCR-amplified DNA from extracts of BNYVV-infected samples. DNA fragments of the expected sizes of about 500 bp, 430 bp, 860 bp and 600 bp for RNA 1 to 4, respectively were obtained for samples with positive reaction in ELISA (Koenig et al., 1995). No amplification was obtained with negative controls. The PCR product in testing root beards for presence of *P. betae* was amplified as approximately 170 bp. These molecular data also emphasize previous data on the presence of BNYVV in the Marvdasht region.

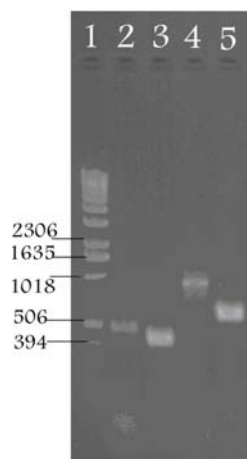

Fig. 1. Detection of BNYVV by RT-PCR. Ethidium bromide-stained agarose gel of RT-PCR products using specific oligonucleotide primers designed to amplify various regions on BNYVV RNA 1 to 4. Lane 1 molecular weight marker, Fermentas (Lithuania), lane 2, RNA 1 (500 bp); lane 3, RNA 2 (430 bp); lane 4, RNA 3 (859 bp); lane 5, RNA 4 (602 bp).

This report demonstrated widespread occurrence of BNYVV all throughout the Marvdasht region based on biological, serological and molecular data. According to the economical importance and long incubation period of this disease that once we observe and diagnose the disease, the inoculum has already increased to a high level, it is suggested that controlling measures must be taken to control multiplication and spread of this virus.

Planting tolerant or partially resistance cultivars and farm sanitation are considered as important measures that every farmer must consider. Moreover, other control measures, including planting as early as possible in soils with temperatures that are too cool for infection by this vector, limiting irrigation duration and increasing frequency, lengthening crop rotations and soil fumigation have been successfully used in reducing the incidence, severity and losses to rhizomania (Rush and Heidel, 1995; Tamada, 2002).

References

- Dunoyer, P., Pfeffer, S., Fritsch, C., Hemmer, O., Voinnet, O. and Richards, K. E. (2002). Identification, subcellular localization and some properties of a cysteine-rich suppressor of gene silencing encoded by peanut clump virus. *Plant J.* 29, 555–567.
- FAO.2001.FAO production yearbook. vol.53.Rome.
- Henry, C.M., Harju, V. , Brewer, G. and Barker, I. (1992). Methods for the detection of Rhizomania in soil. *Aspects of Applied Biology* 32, 129-133.
- Izadpanah,k., Hashemi, P., Kamran,R., Pakniat, M., Sahandpoor, A. and Masoomi, M. (1996). Presence of pseudo-rhizomania disease in Fars. *Iranian Plant Pathology* 32, 200-206.
- Koeing, R., Luddecke, P., and Haeberle, A.M. (1995). Detection of beet necrotic yellow vein virus strains, variants and mixed infection by examining single-strand conformation polymorphisms of immunocapture RT-PCR products. *J. Gen. Viro.* 79, 2051-2055.
- Meunier, A., Schmit, J. F., Stas, A., Kutluk, N., and Bragard, C. (2003). Multiplex reverse transcription PCR for simultaneous detection of Beet necrotic yellow vein virus, Beet soil-

- borne virus, and Beet virus Q and their vector *Polymyxa betea* Keskin on sugar beet. *Appl. Environmental Microb.* 69, 2356-2360.
- Richards, K.E. (1991). Plant Viruses Online, Descriptions and Lists from the VIDE Database Beet necrotic yellow vein *furovirus*. <http://image.fs.uidaho.edu/vidе/descr086.htm>.
- Rush, C.M., and Heidel, G.B. (1995). Furovirus diseases of sugar beets in the United States. *Plant Disease* 79, 868-875.
- Tamada, T. (1999). Benyviruses, p. 154-160. *In* R. Webster and A. Granoff (eds.), *Encyclopedia of virology*, 2nd ed., vol. II. Academic Press, New York, N.Y.
- Tamada, T. (2002). Beet necrotic yellow vein virus. *Description of plant viruses*. CMI/A.A.B.No 391.

Epidemiological aspects of soil-borne viruses of wheat, triticale and rye in Germany

Ute Kastirr, Frank Rabenstein and Thomas Kühne

Federal Centre for Breeding Research on Cultivated Plants, Institute of Resistance Research and Pathogen Diagnostics. D-06449 Aschersleben, Germany

Summary

Epidemiological aspects of soil-borne virus diseases in cereals were investigated. The occurrence of the bymovirus *Wheat spindle streak mosaic virus* (WSSMV) and the furoviruses *Soil-borne wheat mosaic virus* (SBWMV) und *Soil-borne cereal mosaic virus* (SBCMV) was analyzed in different infested soils of cereal growing areas. In Germany the SBCMV and WSSMV are common mainly in rye and triticale growing areas. Mostly these fields are mixed infestations with both viruses. Monoclonal antibodies are developed for specific discrimination of furoviruses. The disease progress was observed with the help of susceptible standard varieties of winter forms of wheat, triticale and rye depending on different sowing times. Virus infection of plant roots occurred 2 months after sowing independent from the sowing time. The virus detection in these cereals differs during the vegetation time. Two pathotypes of SBCMV were detected by the resistance screening of an assortment of resistant wheat cultivars, double haploid (DH) lines and gene bank accessions of wheat in the infested locations Gödnitz (SBCMV-Gö) and Walternienburg (SBCMV-WN).

Introduction

A soilborne wheat virus was first detected in the USA around the beginning of the last century (McKinney, 1923) and described as the *Soilborne wheat mosaic virus* (SBWMV). About 60 years later furoviruses were found in European countries on different cereals. These viruses were designated with several names as *Wheat soilborne mosaic virus* (WSBMV) (Proeseler *et al.*, 1982) and *Soilborne rye mosaic virus* (SBRMV) (Koenig *et al.*, 1999) in Germany. Similar furoviruses isolated from wheat or durum wheat in France, Italy, Great Britain, Denmark and Poland were referred to as strains of SBWMV. The serological discrimination of these virus isolates was difficult on the basis of high coat protein identities up to now (Kastirr *et al.*, 2004). All these isolates share considerably less sequence identity with strains of SBWMV from the USA. Therefore it has been proposed that the European strain group should be classified as a separate species named SBCMV. The epidemiological investigation of soil-borne viruses in Germany showed a wide spreading of SBCMV and WSSMV in the main rye and triticale growing areas (Huth and Lesemann, 1996; Kastirr *et al.*, 2002). Recently Koenig and Huth (2003) for the first time have confirmed the natural infection of wheat by a strain of SBWMV in a field in Southern Germany (Heddesheim) by sequencing. The development of selection methods for resistance to soil-borne viruses requires the investigation of the influence of epidemiological factors on the disease progress and methods for clearly discriminating between pathogens.

Materials and Methods

Serological discrimination

The ATCC type strain of SBWMV and the German SBCMV isolates 'Eilte', 'Eickeloh' and 'Heddesheim' were purified by differential ultracentrifugation from inoculated rye plants of

variety 'Nikita' and used as antigen for polyclonal antiserum production in rabbits and for immunization of mice for production of monoclonal antibodies. Altogether 12 polyclonal antisera originating from different sources and prepared against viral antigens from purified furovirus preparations were tested in various immunological detection systems (Kastirr *et al.* 2004). Monoclonal antibodies were obtained against the type strain of SBWMV and SBCMV isolate 'Eickeloh' using standard cell fusion and cloning techniques. Positive hybridoma clones were selected and infected plant sap was used as antigen in TAS-ELISA.

Epidemical investigation

The discrimination of furovirus isolates on different eukaryotic indicator plants was tested. The influence of different pathogen populations on the virus resistance in cereals was observed in fields in Eickeloh infested by SBCMV, Gödnitz (Gö) and Walternienburg (WN) infested by SBCMV and WSSMV, and Heddeshheim infested by SBWMV. Different genotypes of wheat (113 cultivars, 64 DH lines, 104 gene bank accessions), of triticale (20 cultivars, 54 breeding lines, 63 gene bank accessions) and of rye (71 cultivars, 108 breeding lines, 587 gene bank accessions) were tested for virus resistance in field conditions. The cereals were sown in randomized field experiments with 4 repetitions at 4 infested locations. The virus infection was counted in 10 plants per genotype and repetition at 3 times at intervals of 4 weeks. The results of disease progress were obtained by assessment of virus infection of susceptible standards of wheat, triticale and rye from February to June in 3 different infested locations with sowing times at the middle and the end of September and at the middle of October. The virus detection occurred by DAS/TAS-ELISA in leaves and by tissue print immune assay (TPIA) in plant roots.

Results and discussion

Discrimination of furoviruses

The differentiation of furovirus by symptoms on cereal plants and the eukaryotic indicator plant *Chenopodium quinoa* after mechanical inoculation is impossible. But *Nicotiana benthamiana* is suitable for biological discrimination between the furoviruses SBCMV and SBWMV and virus multiplication. The tested SBCMV isolate caused systemic infections with yellow spots in leaves and a high virus concentration was detected by DAS-ELISA. After leaves were inoculated with SBWMV isolate, systemic plant infection showing a diffuse yellowing mosaic was developed. By use of 12 polyclonal antisera to *Soil-borne cereal mosaic virus* (SBCMV) or *Soil-borne wheat mosaic virus* (SBWMV) it was impossible to discriminate clearly the two viruses neither in DAS-ELISA nor by Western blots. For the detection of SBWMV a DAS-ELISA format based solely on MAB 4G4 could be developed. For specific detection of SBCMV MAB 4G11 can be applied in a TAS-ELISA system (Table 1). The virus species specific MABs allow TPIA a discrimination between both furoviruses and can be applied in routine resistance tests.

Epidemical investigation

The virus infection was naturally established 2 months after sowing in the plant roots independent from the sowing time. The detection of furovirus and bymovirus in infected field plants was dependant on the temperature conditions during the vegetation period. The SBCMV infection in roots develops more rapidly than the WSSMV in autumn (2 months after sowing). The SBCMV transmission in the leaves can be proved 4 months after sowing at first in rye plants. The infection of leaves of wheat and triticale followed about 4 weeks later. The SBCMV tolerates a broad temperature spectrum under field conditions and once established, infection in field plants is detectable until the harvest time. In contrast to this, the propagation of the WSSMV seems to be restricted to lower temperatures. Consequently, this virus is detected best at the end of February until the beginning of April (Fig. 1). This factor is very important for the observance of definite test times of the resistance screening of different genotypes. Rye was

most susceptible to both viruses in all infested locations followed by triticale and durum wheat. Compared to this, bread wheat showed a delayed infection and virus multiplication in the fields Eickeloh and Gödnitz. The virulence of pathogen populations varies in the observed infested locations. Two pathotypes of SBCMV were detected in infested fields in Gödnitz (SBCMV-Gö) and Walternienburg (SBCMV-WN). The descriptive resistance in standard wheat cultivars (*Ares, Autan, Caesar, Charger, Claire, Hereward, Ökostar, Tremie*) was confirmed by testing these cultivars for resistance to SBCMV-Gö. But this resistance was broken by SBCMV-WN. The susceptible wheat standard was infected by both SBCMV pathotypes and by WSSMV isolates from both locations too (Table 2). Five of 64 DH lines of crosses between the resistant variety *Tremie* and susceptible wheat cultivars showed resistance to SBCMV-Gö and could be infected by SBCMV-WN. Sources of resistance in wheat to WSSMV and different furoviruses were deduced in gene bank accessions. Within the GRIN – US accessions 12 forms with WSSMV resistance were found, 3 populations with resistance to furoviruses and 4 genotypes were not infected by SBCMV pathotypes. Plants of 2 HTRI accessions and their progenies couldn't be infected by WSSMV and SBCMV pathotypes in successive experiments. Virus-free single plants of 2 rye accessions were included in breeding programs for development of virus resistant cultivars. These results suggest that the tested material groups include genotypes with different resistance reactions dependent on pathogen populations.

Acknowledgements

Funding of this work by the InnoPlanta Plant Bioengineering Initiatives of BMFB of Germany (FK 03i0607, FK 03i0623, FK 03i0645) is acknowledged. The resistance screening of DH lines has been taken in cooperation with Wheat Protect EU Contract (COOP-CT-2004-512503). We thank the plant protection offices of Saxony-Anhalt, Saxony and Thuringia for the support in monitoring of virus occurrence and the Germplasm collection of IPK Gatersleben and Germplasm Resources Information Network (GRIN-US) for providing us with seed material. Many thanks are due to the German breeder companies Hybro-Saatzucht, Lochow-Petkus, Nordsaat Saatzeit, Saatzeit Hadmersleben and Saatzeit Späth for cooperation in breeding methods.

References

- Huth W. and Lesemann D.-E. (1996). Fungus-transmitted soil-borne viruses on rye in Germany. *Journal of Plant Diseases and Protection* **103**, 120-124.
- Kastirr U., Rabenstein F., Kühne T. (2002). Investigation of epidemiology of *Soil-borne cereal mosaic virus* in the German country Saxony-Anhalt. *Proceedings of the Fifth Symposium of the International Working Group on Plant Viruses with Fungal Vectors*, eds C M Rush and U Merz, pp.119-122.
- Kastirr U., Rabenstein F., Kühne T. (2004). *Soil-borne cereal mosaic furovirus*. In: Lapiere, H. & Signoret, P.-A. (eds): *Viruses and Virus Diseases of Poaceae (Gramineae)*, INRA Editions, pp. 580-585.
- Koenig R. and Huth W. (2003). Natural infection of wheat by the type strain of *Soil-borne wheat mosaic virus* in a field in Southern Germany. *European Journal of Plant Pathology* **109**, 191-193.
- Koenig R., Pleij C.W.A., Huth W. (1999). Molecular characterization of a new furovirus mainly infecting rye. *Archives of Virology* **144**, 2125-2140.
- McKinney H H (1923). Investigation of the rosette disease of wheat and its control. *J. Agr.Res.* **23**, 771-800.
- Proeseler G., Stanarius A., Eisbein K. (1982). Nachweis weiterer Viren am Getreide in der DDR. *Archiv für Phytopathologie und Pflanzenschutz* **18**, 397-403.

Table 1: Reaction of selected monoclonal antibodies (MABs) to SBCMV and SBWMV in TAS-ELISA and Western blot

MAB	Antigen/origin	ELISA		Western blot	
		SBWMV	SBCMV	SBWMV	SBCMV
MAB-1	SBWMV/ATCC (4G4 IgG3)	+++	-	+++	-
MAB-2	SBCMV/ASL (3B3 IgM)	-	++	-	-
MAB-3	SBCMV/ASL (4G11 IgG2a)	-	+++	-	-
MAB-4	SBCMV/ASL (4G7 IgA)	-	+	-	-

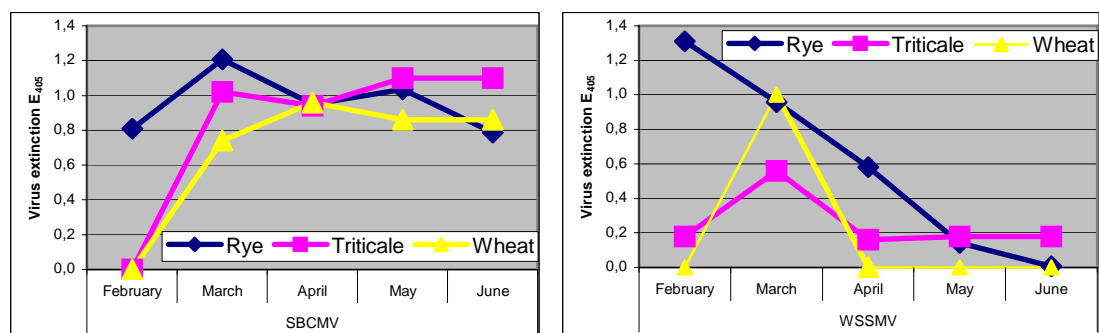

Fig. 1: Virus detection in leaves of wheat, triticale and rye during 9 months after sowing

Table 2: Detection of 2 SBCMV pathotypes :

- 1) SBCMV-Gö confirmed the described resistance of standard wheat cultivars,
- 2) SBCMV-WN confirmed broken resistance

Wheat resistant cultivars	Virus detection by DAS-ELISA (E ₄₀₅)			
	SBCMV		WSSMV	
	Gö	WN	Gö	WN
<i>Ares</i>	0,01	0,35	0,00	0,00
<i>Autan</i>	0,01	0,21	0,00	0,00
<i>Caesar</i>	0,00	0,66	0,00	0,00
<i>Charger</i>	0,03	1,09	0,00	0,28
<i>Claire</i>	0,01	0,42	0,24	0,00
<i>Hereward</i>	0,00	0,93	0,00	0,00
<i>Ökostar</i>	0,04	0,38	0,00	0,00
<i>Tremie</i>	0,01	0,23	0,00	0,00
DH lines				0,00
7	0,00	0,18	0,00	0,00
8	0,00	1,08	0,00	0,00
9	0,00	0,31	0,00	0,00
50	0,00	1,28	0,01	0,00
78	0,03	1,80	0,00	0,00
susceptible standard	1,72	1,91	0,76	1,26

EPIDEMIOLOGICAL SIGNIFICANCE OF SEED TRANSMISSION OF PEANUT CLUMP VIRUS TO PEARL MILLET

Otto G.¹, Dieryck B.¹, De Hertog P.¹, Sauvenier X.¹, Delfosse P.² and C. Bragard¹.

¹ Unité de phytopathologie, Université catholique de Louvain, Louvain-la-Neuve, Belgium.

² Virology, ICRISAT sahelian center, Sadoré, Niger.

Summary

Seed transmission of *Peanut clump virus* (PCV) was assessed under natural conditions for 12 pearl millet accessions. Seed transmission frequencies ranging from 0% to 4.29% were recorded and significant differences between accessions were observed. The virus was detected in 96.7% of the root tips of seedlings infected through seed, raising concerns regarding their role in the spread of the disease. Moreover, horizontal transmission of the virus from plants infected through seed to neighboring pearl millet seedlings was observed. Subsequent tests revealed that capsidial proteins of PCV was localized in several parts of the root apices, notably in the root cap, suggesting that the virus is able to multiply in parts of the apical meristems.

Introduction

Seed transmission is an efficient strategy for the maintenance of a significant viral inoculum potential in annual crops. Persistence of the virus between cultural seasons is insured by the same mechanisms and structures that are responsible for the embryo's survival. Subsequently, the infected progeny renders the viral particles available for further propagation by associated vectors such as aphids, nematodes or protozoa and thus contributes to the spread of the disease.

Only a few phytoviruses are transmitted through seeds of cereals (Table 1.) and their transmission rates tend to stay low, usually under five percent, with the notable exception of *Barley stripe mosaic virus* (BSMV). Few detailed studies of the impact of seed transmission of these diseases (except for BSMV) have been realized, partly because of the difficulty to test high numbers of samples. Hence, the importance in the epidemiology of low levels of seed transmission has often been overseen and few data are available today.

Table 1. Seed transmission rates of phytoviruses in important graminaceous crops.

Virus	Host	Transmission rates
BSMV	<i>Hordeum vulgare</i>	50%-90% (Caroll <i>et al.</i> , 1970)
FoMV	<i>Briza maxima</i>	2% (Paulsen <i>et al.</i> , 1977)
	<i>Avena fatua</i>	1% (Paulsen <i>et al.</i> , 1977)
MCMV	<i>Zea mays</i>	0.04% (Jensen <i>et al.</i> , 1991)
MDMV	<i>Zea mays</i>	0.4% (Hill <i>et al.</i> , 1974)
IPCV	<i>Eleusine coracana</i>	5.2% (Reddy <i>et al.</i> , 1998)
	<i>Setaria italica</i>	9.7% (Reddy <i>et al.</i> , 1998)
	<i>Pennisetum glaucum</i>	0.9% (Reddy <i>et al.</i> , 1998)
WSMV	<i>Zea mays</i>	0.2% (Hill <i>et al.</i> , 1974)

Peanut clump virus (PCV) is transmitted by *Polymyxa graminis* L. (Ratna *et al.*, 1991) and through the seed of groundnut (Konaté and Barro, 1993). The epidemiological significance of the latest is considered as low for the settlement of the disease in healthy fields. This is due to the poor ability of the soil-borne vector to complete its life cycle in the roots of this dicotyledonous host and form significant amounts of viruliferous resting spores (Legrève *et al.*, 2000). Our

studies focused on the seed transmission of PCV in pearl millet (*Pennisetum glaucum*), a monocotyledonous crop traditionally associated or rotated with groundnut and suitable for the multiplication of both the virus and its vector. The risk of perpetuation and dissemination of the virus by this means has been assessed in the following work.

Materials and Methods

The pearl millet accessions tested came from the ICRISAT and INRAN germplasms and were ¾ HK-B78, Ankoutess, GB 87-35, GGP 16, GGT Benin, Gueriniari-2, HKP-GMS, ICMH-9804, ICMV-IS 90311, ICMV-IS 92222, Sosat-C88 and a local breed tentatively called Sadore Local. Seeds from the 12 pearl millet accessions were grown in PCV infested fields during the 2002 rainy season on the experimental station of ICRISAT, Sadore-Niger. The seeds were sown during the last week of June on PCV-N infested patches, demarcated during the 2000 and 2001 rainy seasons. The harvest was carried out at mid-October, at the end of the rainy season. Three weeks before harvest, flag leaf samples of all plants were collected and assayed individually by the penicillinase-based DAS-ELISA as described by Sudarshana *et al.* (1989) using PCV-N antiserum. Samples were considered positive if their absorbance at 620 nm was below the threshold "S" calculated as follow: $S = (T^-) - [(T^-) - (T^+)]/2$, with T^- being the mean absorbance value of six healthy pearl millet controls and T^+ being the mean absorbance value of three infected pearl millet controls.

Panicles from infected plants were collected three weeks later and the seeds from the different panicles were stored separately at 4°C in a dry and ventilated place. For each accession, pearl millet seeds from three to six infected panicles were surface sterilised with 1% NaClO and pregerminated for 24 hours in the dark at room temperature. Germinated seeds were then grown in greenhouses at 25°C to 30°C in plastic trays containing 200 ml of sterilised sand. The plants were watered with a modified Hewit's solution (Hewit, 1966) containing 0.5 mM Fe EDTA. After 15 days of growth, all the plants were tested in groups of 20 by DAS-ELISA. Seedlings from the groups that gave positive ELISA results were subsequently tested individually.

Influence of the accession on the seed transmission rates has been studied and all analysis of data variance in the experiment were performed with the SAS program using the generalized linear model and regression procedures. When the *F* values were significant ($P < 0.05$), the mean comparisons were performed with the least significant difference value procedure (LSD), at the significance level $P = 0.05$.

Infected plants (accession ICMH-9804) contaminated through seeds were grown in the greenhouse (25-30°C) in sterilised sand and watered with the modified Hewit's solution. After three weeks of growth, 5 mm long root tips including the apex were collected and tested by penicillinase-based DAS-ELISA as described above. Other root apices were fixed and embedded in a butyl-methyl methacrylates matrix as described by Ruzin (1999) and 1 µm thick sections were sampled. PCV was detected in the sections by immunohistochemistry (NBT-BCIP) using a polyclonal antibody directed against the capsidial protein of the virus and a secondary monoclonal antibody directed against the first one and linked to alkaline-phosphatase.

Results

Seed transmission of PCV in pearl millet has been observed in plants naturally infected in fields by *Polymyxa graminis* for all accessions except one (GGP-16) (Table 2.) and transmission rates for the different panicles varied between 0% and 4.29% (data not shown). GLM procedure indicates that the accession has a significant effect on seed transmission

Table 2. Seed transmission rates of the various accessions tested under field conditions. (*) Accessions with the same index letter showed no significant differences for seed transmission rates.

Accessions	Seedlings		Mean seed transmission rates* (%)
	tested	infected	
Ankoutess	719	6	0.83 ^{ab}
GB 87-35	1781	2	0.11 ^b
GGP-16	1215	0	0.00 ^b
GGT Benin	822	4	0.49 ^b
Gueriniari 2	884	5	0.56 ^{ab}
¾ HKP-B78	1001	2	0.20 ^b
HKP-GMS	1968	15	0.76 ^{ab}
ICMH 9804	3166	65	2.05 ^a
ICMV-IS 90311	1420	3	0.21 ^b
ICMV-IS 92222	1738	13	0.75 ^{ab}
Sadoré local	634	2	0.31 ^b
Sosat C-88	860	9	1.05 ^{ab}

rates (P value = 0.0003) and LSD method defines two partly overlapping clusters, forming three groups (Table 2.). The first group contains the accession ICMH-9804 with a mean transmission rate of 2.05 %, the second group is intermediary with mean transmission rates ranging from 0.56 % to 1.05 % (Sosat C-88, Ankoutess, HKP-GMS, Gueriniari 2 and ICMV-IS 92222) and the third group contains the accessions with mean seed transmission rates below 0.49 % (GGT-Benin, ICMV-IS 90311, Sadore Local, $\frac{3}{4}$ HK-B78, GB 87-35 and GGP-16). The first and the third groups are significantly different from each other but neither is significantly different from the intermediary group.

Out of the 181 root tips tested from the different plants (accession ICMH-9804), 175 (96.7%) gave positive ELISA results. The capsidial protein of the virus could be found in numerous structures of the root apex and was readily detected in the cortex, the root cap and the distal meristem (Fig. 1).

Discussion

This work highlights the natural occurrence of seed transmission of PVC in pearl millet. The frequencies of PCV infected seeds are similar to those observed for *Indian peanut clump virus* on the same host in India (Reddy *et al.*, 1993). These levels tend to stay low, usually under 2%. Seedlings infected through seeds developed no peculiar symptoms and could only be spotted with molecular tools such as RT-PCR and ELISA. In this work, ICMH-9804 showed a significantly higher susceptibility than the other accessions while no infected seeds were recovered from GGP-16 panicles. This might indicate that resistance to seed transmission is already present in some accessions and they might be used in breeding programs to slow down the spread of the disease. Furthermore, tests realized on accession ICMH-9804 revealed that seeds localized at the base of the panicle are less likely to be infected. Indeed, out of the 800 seeds tested for each location (upper third, middle third and lower third) on seven panicles, only one infected seed was recovered from the bottom part while nine and ten were recovered from the upper and middle parts respectively. This observation can lead to simple cultural techniques in order to reduce the amount of infected seeds in sowing stocks.

However low the seed transmission levels, the presence of the virus in almost 100% of the tested root tips raises concerning questions regarding epidemiology. Root systems of plants infected by PCV through seed may provide viral inoculum for neighbouring *P. graminis* spores. Horizontal transmission of PCV from seed-infected pearl millets to neighbouring plants has been observed under controlled conditions and in presence of healthy *P. graminis* (B. Dieryck, personal communication). This strongly suggests that the same process occurs naturally in the fields, allowing the build-up of significant amounts of PCV-infected resting spores able to propagate the disease to the following groundnut or pearl millet crop.

Presence of the virus in the root cap indicates that the virus is able to invade and multiply in parts of the root meristems. Reports on *Tobacco rattle virus* indicated that presence of the virus in the root cap is a result of the invasion of the quiescent centre by viral information, followed by cell turnover of the quiescent cells into root cap initials (Valentine *et al.*, 2004). This implies an efficient viral process to bypass the plant's defense systems such as post-transcriptional gene silencing. At the epidemiological level, the ability of the virus to reach the root meristems may be partly responsible for the high rate of infected root tips, as

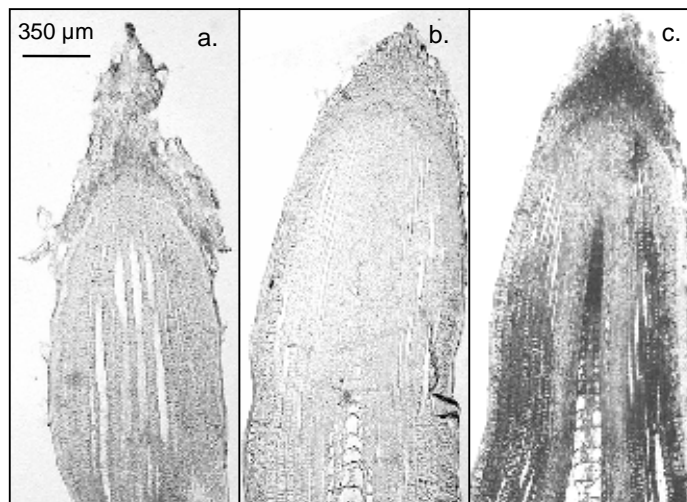

Fig 1. Healthy root tip of pearl millet with both primary and secondary antibodies (a). Infected root tip without primary antibody (b). Infected root tip with both antibodies (c).

the virus may remain in the meristematic structures during the whole development of the root system and infect the cells straight away.

Acknowledgements

This work was funded by the Fonds pour la Formation Recherche dans l'Industrie et dans l'Agriculture (FRIA) in Belgium. We thank the ICRISAT and INRAN for providing *Pennisetum glaucum* seeds and structural support in Niger. We thank A.S. Reddy for providing PCV-N serum.

References

- Carrol, T.W. and Chapman, S.R. (1970). Variation in embryo infection and seed transmission of Barley stripe mosaic virus within and between two cultivars of barley. *Phytopathology* **60**, 1079-1081.
- Hagedorn, D.J. and Gritton, E.T. (1973). Inheritance of resistance to Pea seed-borne mosaic virus. *Phytopathology* **63**, 1130-1133.
- Hewit, E.J. (1966). Sand and water culture methods used in study of plant nutrition. Common Wealth Agricultural Bureau, Farnham Royal Bucks, England.
- Hill, J. H., Martinson, C. A., and Russell, W. A. (1974). Seed transmission of maize dwarf mosaic and wheat streak mosaic viruses in maize and response of inbred lines. *Crop .Sci.* **14**, 232-238.
- Jensen, S.G., Wysong, D.S., Ball, E.M. and Highley, P.M. (1991). Seed transmission of Maize chlorotic mottle virus. *Plant Dis.* **75**, 497-498.
- Konaté G. and N. Barro., (1993). Dissemination and detection of peanut clump virus in groundnut seed. *Ann. Appl. Biol.* **123**, 623-627.
- Legrève, A., Vanpee, B., Delfosse, P. and Maraite, H. (2000). Host range of tropical and sub-tropical isolates of *Polymyxa graminis*. *European Journal of Plant Pathology* **106**, 379-389.
- Paulsen, A.Q. and Niblett, C.L. (1977). Purification and properties of Foxtail mosaic virus. *Phytopathology* 1346-1351.
- Ratna, A. S., Rao, A. S., Reddy, A. S., Nolt, B. L., Reddy, D. V. R., Vijayalakshmi, M. and McDonald, D. (1991). Studies on transmission of Indian peanut clump virus disease by *Polymyxa graminis*. *Ann. Appl. Biol.* **118**, 71-78.
- Reddy, A.S., Hobbs, H.A., Delfosse, P., Murthy, A.K. and Reddy, D.V.R. (1998). Seed transmission of Indian peanut clump virus (IPCV) in peanut and millets. *Plant Dis.* **82**, 343-346.
- Ruzin, S.E. (1999). *Plant microtechnique and microscopy*. Oxford University Press, N.Y. USA.
- Sudarshana, M.R. and Reddy, D.V.R. (1989). Penicillinase-based enzyme-linked immunosorbent assay for the detection of plant viruses. *J. Vir. Meth.* **26**, 45-52.
- Valentine, T., Shawn, J., Block, V.C., Phillips, M.S., Oparka, K.J. and Lacomme, C. (2004). Efficient virus-induced gene silencing in roots using a modified Tobacco rattle virus vector. *Plant Physiol.* **136**, 3999-4009.

**A SURVEY ON THE INCIDENCES OF *BET* NECROTIC YELLOW VEIN VIRUS (BNYVV),
BET SOILBORNE VIRUS (BSBV) AND THEIR VECTOR, *Polymyxa betae* Keskin IN
SUGAR BEET FIELDS IN NORTHERN AND CENTRAL PARTS OF TURKEY**

Nazli D. Kutluk Yilmaz, Semra Saracoglu, M. Ali Sevik and Miray Arli-Sokmen

Department of Plant Protection, Faculty of Agriculture, University of Ondokuz Mayıs, Samsun, Turkey.

Summary

Soil samples were collected from seven important sugar beet growing provinces in northern and central parts of Turkey in 2004. A total of 240 soil samples were used for bait-plant tests and the seeds of a Rhizomania-susceptible cultivar, Arosa were sown in pots using these soil samples. About six weeks later, the roots of sugar beet plants were tested for the presence of BNYVV and BSBV by Enzyme-linked immunosorbent assay (ELISA). Also, the root samples were stained and examined under light microscope to detect the presence of *Polymyxa betae* Keskin cystosori. The percentage of soil samples without *P. betae* cystosori infestation was 8.75% (21 samples). Out of 219 soil samples consisting of *P. betae* cystosori, 127 (58%) were infested with viruliferous *P. betae* cystosori. The percentages of samples infected with BSBV, BNYVV and BSBV+BNYVV were 21.6%, 9.6% and 21.6%, respectively.

Introduction

Sugar beet (*Beta vulgaris* L.) is grown extensively in Turkey on approximately 358.8 ha (Anonymous, 2003). Rhizomania, a soilborne virus disease, is one of the most important sugar beet diseases in Turkey. The agent of rhizomania is *Beet necrotic yellow vein virus* (BNYVV) a member of the genus *Benyvirus* (Tamada, 1999). The virus is transmitted by the soilborne protozoan vector, *Polymyxa betae* Keskin (Asher and Thompson, 1987). Virus can survive within thick-walled resting spores (cystosori) of *P. betae* for at least 15 years in soil (Abe and Tamada, 1986; Rush and Heidel, 1995).

Another soilborne virus, *Beet soilborne virus* (BSBV) was first reported in England in 1982 (Ivanoviç and McFarlane, 1982). BSBV was found in many other countries (Henry *et al.*, 1986; Verhoyen *et al.*, 1987; Lesemann *et al.*, 1989) as well as in Turkey (Meunier *et al.*, 2003). Prillwitz and Schlösser (1992) reported its occurrence in soils in which BNYVV was present. BSBV is morphologically similar to BNYVV, but serologically different. Unlike BNYVV, different serological types of BSBV exist (Mouhanna *et al.*, 2002). BSBV belongs to the Pomovirus genus, is transmitted by *P. betae*, and may cause rhizomania-like symptoms and yield losses up to 70% in sugar beets (Prillwitz and Schlösser, 1992).

The main purpose of this investigation was to determine the incidence of BSBV, BNYVV and *P. betae* in sugar beet fields in central and northern parts of Turkey.

Materials and Methods

Soil Sample

A total of 240 soil samples were collected from sugar beet fields in Samsun, Amasya, Tokat, Çorum, Yozgat, Çankırı and Kastamonu provinces of Turkey in 2004 (Fig. 1). Five to twelve sub-samples were randomly collected in each field and mixed. About one kg of soil was taken per location to a depth of 20 cm (Grünewald *et al.*, 1983).

Bait plant tests

Soil samples collected during surveys were used in bait plant tests. Soil from each sample was ground and mixed with sterile sand (1:1, soil: sand). Then, ten seeds of the rhizomania-susceptible cultivar (Arosa) were sown in 0.5 liter plastic pots containing saturated soil. Each

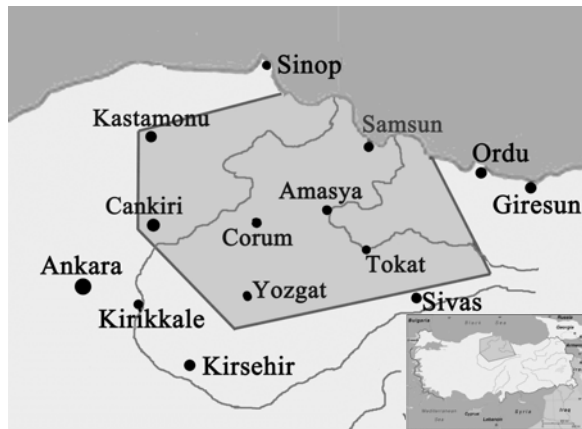

Fig. 1. Dots in the map show centers of the provinces in which surveys were conducted. Map in the corner indicates the survey area in Turkey.

soil sample was used in duplicate. The pots were placed in a plant growth room with alternating temperatures of 22 and 18°C (12/12 h) and watered with Hoagland's solution. The pots were harvested separately after six weeks. The rootlets were washed free of soil and were divided into two parts: one used to test for the presence of viruses by enzyme linked immunosorbent assay (ELISA) and the other for *P. betae*.

Serological Tests

The roots of sugar beet plants were tested for the presence of BNYVV and BSBV by ELISA. The double antibody sandwich ELISA (DAS-ELISA) test was used to determine BNYVV infection by using antiserum supplied by Loewe Biochemica, Sauerlach, Germany. DAS-ELISA was performed according to Clark and Adams (1977), except that extraction buffer included 0.1% nonfat dry milk instead of bovine serum albumin (Arif *et al.*, 1994).

A triple antibody sandwich (TAS)-ELISA was used to test for BSBV. TAS-ELISA was performed according to instructions of the antiserum producer (Loewe Biochemica, Sauerlach, Germany). The plates were measured using a microplate reader (Tecan Spectra II, Grödig/Salzburg, Austria). Samples were considered to be positive when the absorbance at 405 nm (A_{405}) values exceeded the mean of the negative controls by at least a factor of two (Meunier *et al.*, 2003).

Detection of *P. betae*

Rootlet samples taken from bait plants were washed to remove soil debris and stained with lactophenol containing 0.1% acid fuchsin. *P. betae* was checked by observing the amount of resting spore clusters in 10 pieces of the rootlets (about 1 cm long) of each plant under a light microscope (Abe and Tamada, 1986).

Results and Discussion

Infestation of soil with BNYVV, BSBV and fungal vector *P. betae* was assessed by means of a bioassay using sugar beet seedlings as bait plants and ELISA. The percentage of soil samples without *P. betae* cystosori infestation was 8.75% (21 samples out of 240). Of the 219 soil samples testing positive for *P. betae* cystosori, 127 (58%) were infested with viruliferous *P.*

betae cystosori. Twenty three samples (9.6%) were positive for BNYVV alone and 52 (21.6%) for BSBV (Table 1). BNYVV and BSBV are closely related pathogens and widely distributed in sugar beet growing regions. Both pathogens are vectored by the zoospores of *P. betae*. In most cases, BSBV and BNYVV occurred together (Turina *et al.*, 1996; Mouhanna *et al.*, 2002 and Meunier *et al.*, 2003). Thus, the frequency of BSBV and BNYVV mixed infection was 52 (21.6%) in this study.

Table 1. The presence of BNYVV, BSBV and *P. betae* Keskin in sugar beet fields in northern and central parts of Turkey.

Provinces, Districts	No. of soil samples tested	Viruliferous <i>P. betae</i>			Non-viruliferous <i>P. betae</i>
		BNYVV	BSBV	BNYVV +BSBV	
SAMSUN					
Bafra	49	5	9	8	19
Carşamba	34	1	2	1	24
Havza	11	1	2	2	5
Vezirokoprü	7	0	0	4	3
Kavak	6	0	4	1	1
Ladik	5	0	3	0	2
Alacam	2	0	0	0	1
Tekkekoy	1	0	0	0	1
AMASYA					
Merkez	17	3	3	3	6
Merzifon	11	0	3	2	6
Tasova	9	1	1	7	0
Gumushacikoy	10	0	6	2	2
Suluova	12	1	2	5	3
ÇORUM					
Osmancık	11	2	2	5	2
Sungurlu	11	1	3	1	6
Alaca	5	0	2	0	3
Lacin	4	0	0	3	1
İskilip	3	1	0	1	1
TOKAT					
Erbaa	13	4	4	5	0
ÇANKIRI					
Kizilirmak	12	3	3	1	3
YOZGAT					
Yerkoy	6	0	3	0	3
KASTAMONU					
Taşkopru	1	0	0	1	0
TOTAL		240	23	52	52
%			9.6	21.6	21.6

The total percentage of BSBV single and mixed infections (43.2%) was found to be higher than that of BNYVV single and mixed infections (31.2%) in the soil samples tested. The frequency of virus infection depends on environmental conditions and inoculum densities of the viruliferous population of *P. betae* (Rush, 2003). Our growing conditions were appropriate for both viruses. Inoculum density of *P. betae* viruliferous population carrying BSBV might be high in our soil samples because BSBV infection was superior to BNYVV infection in this study. Also,

the titer of BSBV was high relative to that of BNYVV in 82.7% (43 samples) of the mixed infected samples. The mean absorbance value of BNYVV was 0.635 whereas that of BSBV was 1.609 in mixed infected samples. Similarly, it was reported that the virus with the highest inoculum density in naturally infected soil samples usually colonize more in the root system, and the virus that infects the root system first usually reaches high levels (reviewed by Rush, 2003).

Mixed infections are rather common in nature. This is especially so in areas where a diversity of vectors or a single vector may carry different virus species. Our data showed that 21.6% of the samples were double-infected. When two unrelated plant viruses infect a plant simultaneously, synergistic viral interactions often occur (Martin *et al.*, 2004). Such synergism can induce symptoms more severe than those caused by single infections and may enhance the virus titer. The student *t* test was used to estimate such synergism in mixed infections of BNYVV and BSBV. Statistical differences between the mean absorbance values in single and mixed infections for each virus were analyzed by using SPSS statistical software, version 12 (Systat Software Inc., Chicago, IL, USA). According to this analysis, there was no statistical significant difference ($p > 0.05$) between the mean absorbance values for single and double infections of BNYVV or BSBV. This result showed consistency with symptom expressions of these viruses in single and mixed infected bait plants in our study.

References

- Abe, H., and Tamada, T. (1986). Association of beet necrotic yellow vein virus with isolates of *Polymyxa betae* Keskin. *Annls. Phytopath. Soc. Jap.* **52**, 235-247.
- Anonymous, (2003). Agricultural structure (production, price, value). State Institute of Statistics, Printing Division, Ankara, p. 544.
- Arif, M., Torrance, L., and Reavy, B. (1994). Improved efficiency of detection of potato mop-top furovirus in potato tubers and in the roots and leaves of soil-bait plants. *Potato Res.* **37**, 373-381.
- Asher, M. J. C., and Thompson, K. (1987). Rhizomania in Europe. *Br. Sugar Beet Rev.* **55**, 24-28.
- Clark, M., and Adams, A. M., (1977). Characteristics of microplate method of enzyme-linked immunosorbent assay for the detection of plant viruses. *J. Gen. Virol.* **34**, 475-483.
- Grünwald, I., Horak, I., and Schlösser, E. (1983). Rhizomania. III. Verbreitung im hessischen und im raum worms sowie beziehungen zum boden-pH und zur fruchtfolge. *Zuckerindustrie* **108**, 650-652.
- Henry, C. M., Jones, R. A. C., and Coutts, R. A. (1986). Occurrence of a soil-borne virus of sugar beet in England. *Plant Pathol.* **35**, 585-591.
- Ivanović, M., and McFarlane, I. (1982). A tubular virus associated with infection of sugar beet by *P. betae*. *Rep. Rothamsted Exp. Stat.* for **1981**, 190-191.
- Lesemann, D. E., Koenig, R., Lindsten, K., and Henry, C. (1989). Serotypes of beet soil-borne furovirus from FRG and Sweden. *Bull. EPPO/OEPP* **19**, 539-540.
- Martin, E. M., Cho, J. D., Kim, J.S., Goeke, S.C., Kim, K.S. and Gergerich, R.C. (2004). Novel cytopathological structures induced by mixed infections of unrelated plant viruses. *Phytopathology*, **94**: 111-119.
- Meunier, A., Schmit, J-F., Stas, A., Kutluk, N., and Bragard, C. (2003). Multiplex reverse transcription for simultaneous detection of beet necrotic yellow vein virus, beet soilborne virus, and beet virus Q and their vector *Polymyxa betae* Keskin on sugar beet. *App. Environ. Microbiol.* **69** (4), 2356-2360.
- Mouhanna, A. M., Nasrallah, A., Langen, G., and Schlösser, E. (2002). Surveys for Beet necrotic yellow vein virus (the cause of rhizomania), other viruses, and soil-borne fungi infected sugar beet in Syria. *J. Phytopath.* **150**, 657-662.
- Prillwitz, H. and Schlösser, E. (1992). Beet soil-borne virus: occurrence, symptoms and effect

- on plant development. *Med. Fac. Landbouw. Univ. Gent.* **57/2a**, 295-302.
- Rush, C. M. and Heidel, G. B. (1995). Furovirus diseases of sugar beets in the United States. *Plant Dis.*, **78**, 868-875.
- Rush, C. M. (2003). Ecology and Epidemiology of Benyviruses and Plasmodiophorid Vectors. *Annual Review Phytopath.* **41**, 567 - 592.
- Tamada, T. (1999). Benyviruses, p. 154-160. In R. Webster and A. Granoff (ed.) *Encyclopedia of Virology*, 2nd Edn., Vol. II. Academic Press, New York, N. Y.
- Turina, M., Resca, R., and Rubies-Autonell, C. (1996). Surveys of soilborne virus diseases of sugar beet in Italy. p.121-124. In L. Sherwood and C. M. Rush (ed.), Proceedings of the Third Symposium of the International Working Group on Plant Viruses with Fungal Vectors. American Society of Sugar Beet Technologists, Denver. Colo.
- Verhoyen, M., Van Den Bossche, M., and Van Steyvoort, L. (1987). Identification de nouveaux virus de la betterave en Belgique. *Rev. Agric. (Brussels)* **40**, 1463.

STUDY OF *BET* SOILBORNE VIRUS AND *BET* VIRUS Q HOST RANGE AND DISTRIBUTION IN INFECTED PLANTS.

I. Homa, M. Zouhar and P. Rysanek

Department of Plant Protection, Czech University of Agriculture, 165 21 Prague, Czech Republic, ihmedhoma@yahoo.co.uk

Summary

The host range of newly collected isolates of *Beet soilborne virus* (BSBV) and *Beet virus* Q (BVQ) was further studied. Seeds of tested plant species were sown into soil contaminated with viruliferous *Polymyxa betae*. Compared to our previous studies, the new isolate of BSBV infect not only beets and spinach but also *Chenopodium quinoa*, *C. murale*, *C. vulvaria* and *Amaranthus tricolor*. These isolates also differs in translocation in plants. Whereas previously used isolates were confined to roots of sugar or red beet only, this isolate also spreads to the hypocotyl and leaves of sugar beet and spinach. BSBV was proved in these parts by PCR, ELISA and also by mechanical inoculation of *C. quinoa* leaves. Sometimes the concentration of virus in hypocotyl and leaves was higher than in roots. Now we are searching for the reason of these differences. BVQ was found in roots of sugar beet, some varieties of spinach, *C. vulvaria* and *C. quinoa* and also in hypocotyls and leaves of sugar beet and spinach.

Introduction

BSBV was first found by Ivanovic and Mcfarlane (1982) in England and later described by Henry et al. (1986). It is widespread in sugar beet growing areas all over the world (Prillwitz and Schlosser (1992), Lindsten (1991), Turina et al. (1996) including Czech Republic (Rysanek and Kudlackova, 2000). The virus is transmitted by *Polymyxa betae* (Ivanovic et al., 1983) and fulfils criteria to be included into genus *Pomovirus* (Hull, 2002). The host range of BSBV was studied by Henry et al. (1986) using mechanical inoculation of leaves of tested plant species. In our previous study with natural inoculation via *P. betae* zoospores, only beets (sugar, red, and fodder beet and mangold) and spinach were infected (Kudlackova and Rysanek, 2002). In all these cases only roots of bait plants contained the virus (Rysanek, unpublished data).

BVQ was originally considered to be a serologically distinct strain of BSBV, but Koenig (1998) proved its different RNA composition substantiating its separation from BSBV as a new virus. The host range of BVQ is supposed to be similar as that of BSBV but in fact no data are available. The same situation applies to BVQ distribution in infected plants.

Materials and Methods

New soil sample were collected in traditional sugar beet growing area near Mlada Boleslav (Central Bohemia). This area is known from our previous studies to be highly contaminated by *P. betae*, but not with another *P. betae* transmitted virus, *Beet necrotic yellow vein virus*, BNYVV. Baiting plants from the families *Chenopodiaceae*, *Caryophyllaceae* and *Amaranthaceae* (sugar beet cv. Hilma, spinach varieties Lambada, Carambole, San Marco, Matador, Hercules, Polydane, Orbita and Monores, *Atriplex calotheca*, *A. hortensis*, *A. procera*, *A. sagittata*, *Axyris amaranthoides*, *Chenopodium album*, *C. ambrosioides*, *C. capitatum*, *C. foliosum*, *C. murale*, *C. quinoa*, *C. septaderlanum*, *C. urbicum*, *C. vulvaria*, *Stellaria graminea*, *Carastium lanatum*, *Minuratia laricifolia*, *Petroshygia saxifraga*, *Amaranthus blitoides*, *A. blitum*, *A. tricolor*) were sown into this soil and kept in a climatized room at 22 °C, 16/8 h day/night

regime. After six weeks plants were harvested, their roots washed and tested for the presence *P. betae* cystosori by light microscopy and presence of BSBV and BVQ was determined by PCR as described by Zouhar and Rysanek (2000). If virus was found in roots, hypocotyls and leaves also were tested. If not, plants were tested again an additional two weeks. In the cases when virus was found in above ground parts, ELISA tests, using antibodies from DSMZ Plant Virus Collection Braunschweig in PTA format and mechanical inoculation of *C. quinoa* leaves using HEPES buffer pH 7,5 with 5 % of PVP, were also employed to confirm virus presence. Local lesions on *C. quinoa* leaves were retested by PCR. Subsequent inoculations from lesions to *C. quinoa* leaves were also done.

Results and Discussion

P. betae cystosori were found by light microscopy only in sugar beet, spinach, *A. tricolor*, *C. vulvaria*, *C. quinoa*, *C. murale*, *C. urbicum*, and *C. album*. From all tested species, only sugar beet, *C. vulvaria* and some varieties of spinach (Lambada, Carambole, San Marco, Matador) were found to be infected by both viruses (Fig. 1, 2.). In all these cases, viruses were present in roots, hypocotyls and leaves, even when leaves could be infected later. Sometimes they contained less but sometimes even more virus than roots. These results were confirmed both by ELISA (both viruses) and by mechanical inoculation (BSBV only). Mechanical transmission of BVQ were unsuccessful. From the same inoculation, some lesions appeared after six days but others no sooner than 12 days. When subsequent inoculations were done local lesions usually resulted from first inoculation (from roots or systemically infected hypocotyl or leaves) whereas in the case of second inoculation (from local lesions) vein banding with marginal necrosis usually appeared (Fig. 3, 4.). From third inoculations, neither reaction in test plants could be seen, and the virus was not found in them when tested by PCR. Some varieties of spinach (Hercules, Polydane, Orbita and Monores) and *C. murale* were infected by BSBV only and BVQ could not be found in them by PCR. On the contrary, in some cases BVQ only was detected in *C. quinoa* roots and stems by PCR.

These results extend our previous work (Kudlackova and Rysanek, 2002). Even when BSBV and BVQ were found in some other species like *C. vulvaria*, *C. murale* or *C. quinoa*, it still can be said that their natural host range is very narrow containing three genera with five species only. According to Henry et al. (1986) *C. album*, *C. amaranthicolor*, *C. foetidum*, *C. murale*, *C. polyspermum* and *C. quinoa* can be infected by mechanical inoculation of leaves. However, from these species only *C. quinoa* and *C. murale* were infected by *P. betae* zoospores in our experiments (these and those of Kudlackova and Rysanek, (2002)). Some of them are not at all infected by *P. betae*, others, like *C. album*, may be immune to infection via roots or concrete forma speciales of *P. betae* is not able to transmit the viruses.

More interesting results concern distribution of both viruses in plants. When working with our previous two isolates of BSBV, viruses were found in roots only. This new isolate seems to be able to spread systemically into above ground parts as proved by PCR, and two other independent methods. Now we want to determine what is the reason for this difference. Another interesting thing is the change of character of symptoms caused by BSBV between first and second passage on *C. quinoa* leaves. Maybe, there are some deletions in the virus RNA causing this change of symptoms and finally loss of infectivity, as it is known from the case of BNYVV (Bouzobaa et al., 1991).

References

- Bouzobaa S., Niesbach-Klosgen U., Jupin I., Guilley H., Richards K., Jonard G. (1991): Shortened forms of beet necrotic yellow vein virus RNA-3 and RNA-4: internal deletions and a subgenomic RNA. *J. Gen. Virol.* **72**, 259-266.

- Henry C. M., Jones R. A. C., Coutts R. H. A. (1986): Occurrence of a soil-borne virus of sugar beet in England. *Plant Pathology* **35**, 585-591.
- Hull R. (2002): *Plant virology*. AP San Diego, 1001 pp.
- Ivanovic M., Macfarlan I. (1982): A tubular virus associated with infection of sugar beet by *Polymyxa betae*. *Rothamsted Exp. Stn. Rep.* 1981, 190-191.
- Ivanovic M., McFarlane I., Woods R. D. (1983): Viruses of sugar beet associated with *Polymyxa betae*. *Rothamsted Exp. Stn. Rep.* 1982, 189-190.
- Koenig R. (1998): Genome properties of beet virus Q, a new furo-like virus from sugarbeet, determined from unpurified virus. *J. Gen. Virol.* **79**, 2027-2036.
- Kudlackova P., Rysanek P. (2002): Study of host range of the Beet soilborne pomovirus. *Proc. 5th Symp. IWGPVFFV, Zurich*, 100-102.
- Lindsten K. (1991): Report on *P. betae* - transmitted beet viruses in Sweden. Beet necrotic yellow vein virus workshop, Colmar, 39-42.
- Prillwitz H., Schlosser E. (1992): Beet soil-borne virus: occurrence, symptoms and effect on plant development. *Med. Fac. Landbouww. Univ. Gent* 57/2a, 295-302.
- Rysanke P., Kudlackova P. (2000): Distribution of soilborne viruses infecting sugar beet in the Czech Republic. *Proc. 5th Congr. EFPP, Giardini Naxos*, 226-227.
- Turina M., Resca R., Rubies-Autonnel C. (1996): Survey of soil-borne virus diseases of sugar-beet in Italy. *Proc. 3rd symp. IWGPVFFV, Dundee*, 185-188.
- Zouhar M., Rysanke P. (2000): Detection and differentiation of Beet soilborne virus and Beet virus Q by PCR. *Proc. 5th Congr. EFPP, Giardini Naxos*, 230-232.

Figures



Fig 1. Host range testing of roots of baiting plants by RT-PCR.

- | | |
|-----|----------------------------------|
| M | Markers |
| 1. | Negative control |
| 2. | Positive control of BSBV and BVQ |
| 3. | <i>C. quinoa</i> |
| 4. | <i>C. vulvaria</i> |
| 5. | <i>C. album</i> |
| 6. | <i>C. urbicum</i> |
| 7. | <i>C. murale</i> |
| 8. | <i>Amaranthus tricolor</i> |
| 9. | <i>Spinacia oleracea</i> |
| 10. | <i>A. blitoides</i> |

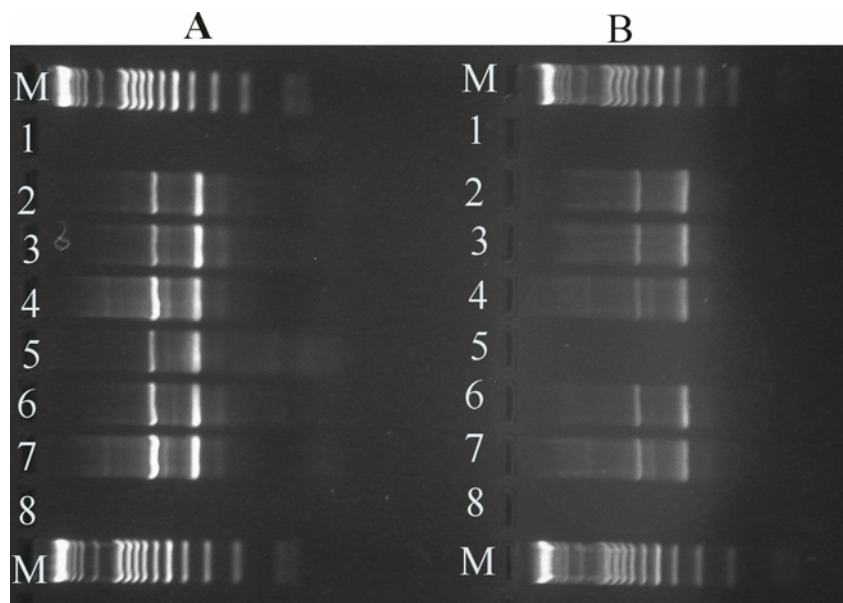

Fig. 2. Results of testing of spinach varieties by RT-PCR.

A	Markers	B
M		M
1.	Negative control	1
2.	Positive control of BSBV and BVQ	2
3.	Lambada roots	3. San Marco roots
4.	Lambada hypocotyl	4. San Marco hypocotyl
5.	Lambada leaves	5. San Marco leaves
6.	Carambole roots	6. Matador roots
7.	Carambole hypocotyl	7. Matador hypocotyl
8.	Carambole leaves	8. Matador leaves



Fig. 3. BSBV local lesions on *C. quinoa* plants after mechanical inoculation with homogenate from sugar beet roots. Healthy leaf on the left.



Fig. 4. Vein banding on *C. quinoa* plants after subsequent mechanical inoculation with homogenate from local lesions.

DETECTION OF BEET NECROTIC YELLOW VEIN VIRUS IN LITHUANIA

Elena Jackeviciene¹, Juozas Staniulis², Irena Zitikaite², Loreta Taluntyte¹, Lina Jankuviene¹, Ilona Vascilo¹

¹Lithuanian State Plant Protection Service, Vilnius, LT-11351, Lithuania

²Plant Virus Laboratory Institute of Botany, Vilnius, LT-08406, Lithuania

Summary

A survey of sugar beet crops for the presence of *Beet necrotic yellow vein virus* (BNYVV) in Lithuania was undertaken from 1998 using DAS-ELISA as a detection method. In 2004 in one area of the South-west region of Lithuania, sugar beet roots with branched tips and enlarged quantities of small rootlets were collected and samples of rootlets reacted positively for BNYVV using the kits from BIOREBA AG and LOEWE. When sugar beet seeds were sown in soil collected from the rhizomania infected field, the germinated plants rootlets appeared thicker and had brown discoloration. The samples of rootlets gave a positive reaction with BNYVV in DAS-ELISA tests. These samples in immunosorbent electron microscopy with trapped antibodies from the BIOREBA AG kit revealed the presence of straight, very short and longer particles, about 20 nm in diameter. Mechanical inoculations to *Chenopodium amaranticolor* resulted in development of local chlorotic lesions. These sugar beet rootlets were used for RT-PCR detection BNYVV with primer pairs as recommended by V.Harju from Central Science Laboratory (UK) in Protocol for the diagnosis of the quarantine organism *Beet necrotic yellow vein virus* (2003) and a slightly modified one-step protocol. Using both RT-PCR protocols, amplified products of the expected size were obtained. Thus, detection of BNYVV in Lithuania was confirmed by ELISA in naturally infected sugar beet roots, in rootlets of plants grown in soil from rhizomania infected field, by mechanical transmission to plant-indicator, by morphology of detected virus particles in ISEM, and according to RT-PCR amplification products.

Introduction

Rhizomania is one of the most economically significant sugar beet diseases and can cause reduction in sugar yield of up to 70% (Richard-Molard, 1985). The agent of the disease is *Beet necrotic yellow vein virus* (BNYVV). The virus is transmitted by the plasmodiophorid, obligate parasite of sugar beet roots *Polymyxa betae* Keskin. Initially detected and described in Italy (Canova, 1959), rhizomania is widely distributed in most sugar beet growing areas in Europe and world-wide (Rush and Heidel, 1995; Suarez et al., 1999; Ratti et al., 2005). In Europe, BNYVV has spread from Southern to Northern Europe reaching northern sugar beet growing regions. Recently the first detection of BNYVV was recognized in Sweden (Lennefors et al., 2000) and Denmark (Nielsen et al., 2001). Molecular studies based on reverse transcription-polymerase chain reaction (RT-PCR) and restriction fragment length polymorphism (RFLP) analysis have revealed that two major strain groups of the virus (A and B types) containing only four RNA species are prevalent in

Europe (Kruse et al., 1994). The A type is widespread in Southern Europe, the type B predominates in Germany and France, whereas in the United Kingdom both the A and the B types have been found (Koenig et al., 1995). Type P of BNYVV contains RNA 5, has limited distribution in France and UK and is known to be responsible for severe rhizomania symptoms (Ratti et al., 2005).

Sugar beet crops in Lithuania cover more than 20,000 Ha. Surveys of sugar beet crops for the presence of *Beet necrotic yellow vein virus* have been regularly conducted out since 1998, using DAS-ELISA kits from BIOREBA AG and LOEWE for detection. Here we report evidence of the first detection BNYVV in sugar beet crops in Lithuania.

Materials and Methods

During surveys for the presence of BNYVV, usually about 1/10 of fields are checked. In 2004 in one area of Southwest region of Lithuania, sugar beet plants with branched root tips and enlarged quantities of small rootlets were detected and subjected to standard DAS-ELISA using BIOREBA AG and LOEWE immunological kits (Clark and Adams, 1977). Soil samples from fields with sugar beet plants positive for BNYVV were used for growing sugar beet bait plants of the susceptible variety 'Belmonte', as recommended in Annex 5 of Protocol for the diagnosis of the quarantine organism *Beet necrotic yellow vein virus*, version Jan 2003, drafted by Val Harju and approved by European and Mediterranean PPO as Standard (EPPO, 2004). Roots of these bait plants were used for DAS-ELISA tests, for mechanical inoculation of *Chenopodium amaranticolor* plants, for electron microscopic (EM) investigation of virus particles and for PCR detection of BNYVV.

For observation of presence of virus particles, EM carbon coated grids were sensibilized with BIOREBA antibodies to BNYVV diluted 1:50 in FBS buffer. The grids were placed on drops of root extracts (1:20 tissue/buffer), washed, stained with 2% of UA, and observed with JEOL JEM-100S EM at x 25 000.

For PCR tests, RNA extraction from sugar beet bait plant root tissue was carried out according to the instruction of "QuickPrep™ Total RNA Extraction Kit" for the direct isolation of total RNA (Amersham Biosciences, UK). For this investigation, primer pairs were synthesized and reaction conditions were adopted according to the Protocol for the diagnosis of BNYVV, with some details indicated in a previous publication (Staniulis et al., 2004). For nested PCR, RNA extraction and reaction conditions were according to Annex 2 of the above indicated Protocol.

Results and Discussion

In one region of southwest part of Lithuania BNYVV was detected using two different sources of BNYVV antibodies. Soil samples from BNYVV positive fields were used for growing sugar beet bait plants, 'Belmonte'. Bait plants had roots with dark brown discoloration and slightly bearded appearance (Fig. 1). Tissue extracts from these rootlets gave positive DAS-ELISA results. Leaves from mechanically inoculated *Chenopodium amaranticolor* developed local lesions (Fig. 2). EM investigation using BIOREBA antibodies to BNYVV for increased trapping of virus particles revealed presence of characteristic BNYVV particles about 20 nm in diameter and of several

different lengths, the majority of them being slightly longer than 260 nm (Fig. 3). Agarose gel electrophoresis of RT-PCR products revealed expected BNYVV products of 500 bp size (Fig. 4.) and for nested PCR – specific products of expected size – 326 bp (Fig. 5.).



Fig. 1. Rootlets of sugar beet bait plants grown in soil from a field of rhizomania infected plants.



Fig. 2. Local lesions on *Chenopodium amaranticolor* after inoculation with extract from bait plant rootlets.

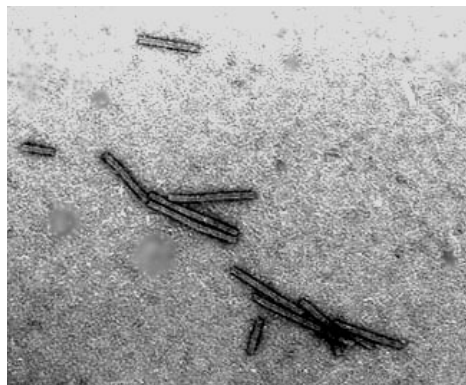

Fig. 3. Characteristic BNYVV particles trapped on an EM grid coated by antibodies against BNYVV from extracts of sugar beet bait plant rootlets. Virus particles in the middle of the picture are a bit longer than 260 nm.

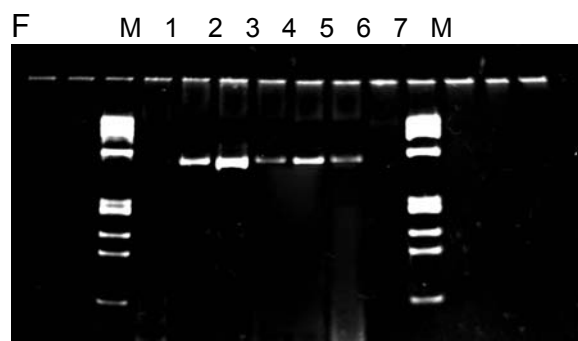

Fig. 4. RT-PCR products from extracts of sugar beet bait plants using BNYVV specific primer pairs. M – DNA ladder PhiX174RFI DNA/HaeIII digest; 1 – 6 samples of extract of beet rootlets; 7 – negative control. Product size is 500 bp.

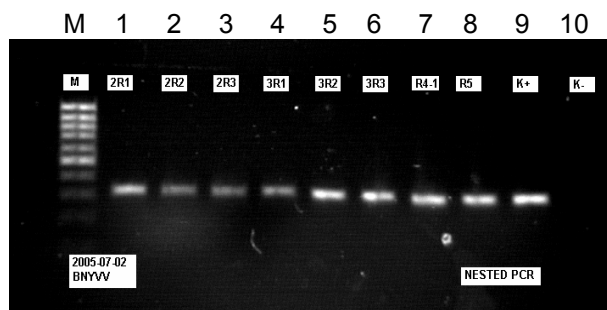

Fig. 5. PCR products using specific nested primers to BNYVV. M – 100 bp, 1 - 8 infected root extract samples; 9 – K+; 10 – K-. Product size is 326 bp.

Results of this investigation indicate that sugar beet seedlings, grown in soil collected from rhizomania infected fields bore diagnostic root symptoms and contained BNYVV. Extracts of these rootlets gave positive results in DAS-ELISA tests, revealed characteristic BNYVV particles, caused LL on inoculated leaves of *C. amaranticolor*, and produced BNYVV specific products in RT-PCR and nested PCR. These findings verify the presence of BNYVV in at least one location in Lithuania. Our findings were confirmed by Dr. C.Ratti at DiSTA, Bologna, who also identified the isolate of BNYVV as the to B type. Limited observation of BNYVV infected plant symptoms on leaves and roots indicate that they are very mild in comparison with described classical symptoms. Positive ELISA results were obtained from sugar beet roots showing a mild degree of degeneration.

Acknowledgements

We express cordial thanks to Dr. Claudio Ratti of Facolta di Scienze Agrarie DiSTA, Bologna, Italy, for confirmation of detection and definition of the type of BNYVV.

References

- Canova A. (1959). Appunti di patologie della barbabietola. *Informatore Fitopatologico* **9**, 390-396.
- Clark M.F., Adams A.N. (1977). Characteristics of the microplate method of enzyme-linked immunosorbent assay for the detection of plant viruses. *J. Gen. Virol.* **34**, 475-483.
- Diagnostic protocols for regulated pests. (2004). Protocol for diagnosis of quarantine organism Beet necrotic yellow vein virus. *EPPO Bulletin* **34(2)**, 229-237.
- Koenig R., Lüddecke P., Haeberle A.M. (1995). Detection of beet necrotic yellow vein virus strains, variants and mixed infections by examining single-strand conformation polymorphisms of immunocapture RT-PCR products. *J. Gen. Virol.* **76**, 2051-2055.
- Kruse M., Koenig R., Hoffmann A., Kaufmann A., Commandeur U., Solovyev A.G., Savenkov I., Burgermeister W. (1994). RFLP analysis of RT-PCR products reveals the existence of two major strain groups of beet necrotic yellow vein virus. *J. Gen. Virol.* **75**, 1835-1842.
- Lennefors B.-L., Lindsten K., Koenig R. (2000). First record of A and B type *Beet necrotic yellow vein virus* in sugar beet in Sweden. *Europ. J. Plant Pathol.* **106**, 199-201.
- Nielsen S.L., Nicolaisen M., Scheel C., Dinesen I.G. (2001). First record of *Beet necrotic yellow vein virus* in Denmark. *Plant Dis.* **85**, 559.
- Ratti C., Clover G.R.G., Autonell C.R., Harju V.A., Henry C.M. (2005). A multiplex RT-PCR assay capable of distinguishing beet necrotic yellow vein virus types A and B. *J. Virol. Methods* **124**, 41-47.
- Richard-Molard M. (1985). Rhizomania: A world-wide danger to sugar beet. *Span* **28**, 92-94.
- Rush C.M., Heidel G.B. (1995). Furovirus diseases of sugar beets in the United States. *Plant Dis.* **79**, 868-875.
- Staniulis J., Zitikaite I., Zvirbliene A., Kaseta V. (2004). Identification of Tobacco necrosis virus from strawberry in Lithuania. *Latvian J. of Agronomy* **7**, 49-54.
- Suarez M.B., Grondona I., Garcia-Benavides, Monte E., Garcia-Acha I. (1999). Characterization of beet necrotic yellow vein furovirus from Spanish sugar beets. *Internatl Microbiol.* **2**, 87-92.

THE OCCURENCE AND DISTRIBUTION OF SUGAR BEET RHIZOMANIA IN CROATIA

Edyta Đermić¹, Bogdan Cvjetković¹ and C. Rubies Autonell²

¹ Faculty of Agriculture, Department of Plant Pathology, Svetošimunska 25, Zagreb 10000, Croatia. ² DiSTA - Plant pathology, University of Bologna, V.le Fanin, 40 - 40127 Bologna - Italy

Summary

Most Croatian sugar beet-growing areas were surveyed to determine the incidence of *Beet necrotic yellow vein virus* (BNYVV). During three years (2002-2004) we checked sugar beet yield and collected 139 root samples from 72 locations in 9 Croatian counties (Virovitica, Županja and Osijek regions). Root tissue was tested by ELISA: 20% of the samples, from 5 counties, were positive for BNYVV. At some locations we also checked virus presence in the soil by ELISA.

This report highlights the distribution of BNYVV in Croatia and the presence of type A in the area where rizomania was first identified (Seleš).

Introduction

Rhizomania is a worldwide disease of sugar beet caused by *Beet necrotic yellow vein virus* (BNYVV). Infected sugar beet plants show leaf symptoms as necrotic yellowing veins or the beard-like appearance of the sugar beet root (Asher, 1999). Virus infection can cause yield losses up to 45-50% in taproot weight, and up to 60-79% in sugar content (Casarini Camangi, 1987). There is a significant reduction in technological quality of beet root due to waste impurities, significant increase of nitrate nitrogen in the root and increase of alkaline coefficient. New leaves have longer stems than healthy ones; they are lighter in color with vein necrosis. In our climate the symptoms on leaves are rare and may disappear but noticeable changes on the root are often observed. Numerous root hairs develop and the root "gets a beard", with necroses visible on the cross section. The disease was first described in Italy (Canova, 1959) and has since been reported from many countries in Europe (Austria, Belgium, Bulgaria, Croatia, Czech Republic, France, Germany, Greece, Hungary, The Netherlands, Poland, Romania, Russian Federation, Slovakia, Spain, Sweden, Switzerland, Turkey, Ukraine, UK and Yugoslavia) and worldwide (Asher, 1993; Tamada, 1999; Lennefors *et al.*, 2000). In Yugoslavia the BNYVV was first detected in 1978 in Serbia (Šutić and Milovanović, 1980). In Croatia rhizomania was first described in 1979 at location Seleš and later observed at other locations: Županja, Privlaka-Otok, Tovarnik, Gradišće and Čakovec. In Slovenia rhizomania was found in 1996 (Vilčar, 1996).

The aim of the present work is to know the distribution of BNYVV in the main sugar beet growing areas in Croatia and, subsequently, to study the presence of the two virus types (A and B) widespread in Europe (Kruse *et al.*, 1994; Koenig *et al.*, 1995).

Materials and Methods

During three years (2002-2004) we checked sugar beet yield and collected root samples for analyses from the major sugar beet growing regions in Croatia. Analyses were performed with the double antibody sandwich DAS-ELISA-test using a commercial kit produced by Loewe Biochemica (Germany). Root tissue was ground in grinding buffer (Loewe Biochemica), following the manufacturer's protocol, using grinding bags by BioRad. The supernatant was used immediately and optical density, at 405 nm, was measured with the Hyperion Micro Reader spectrophotometer.

Soil samples, collected from different locations, were also tested for virus presence growing in susceptible sugar beet plants (cv. Asso) for 45 days. Roots were later analyzed by DAS-ELISA-test using the same protocol previously described.

Molecular analyses were performed on susceptible sugar beets (cv. Asso) grown in two samples of BNYVV infected soil from Seleš. Total ssRNA was extracted from infected roots and cDNA, corresponding to two different regions of the viral genome, was amplified through multiplex reverse transcriptase-PCR (mRT-PCR) using primers from recently published methods for specific BNYVV type A and B diagnosis (Ratti *et al.*, 2005).

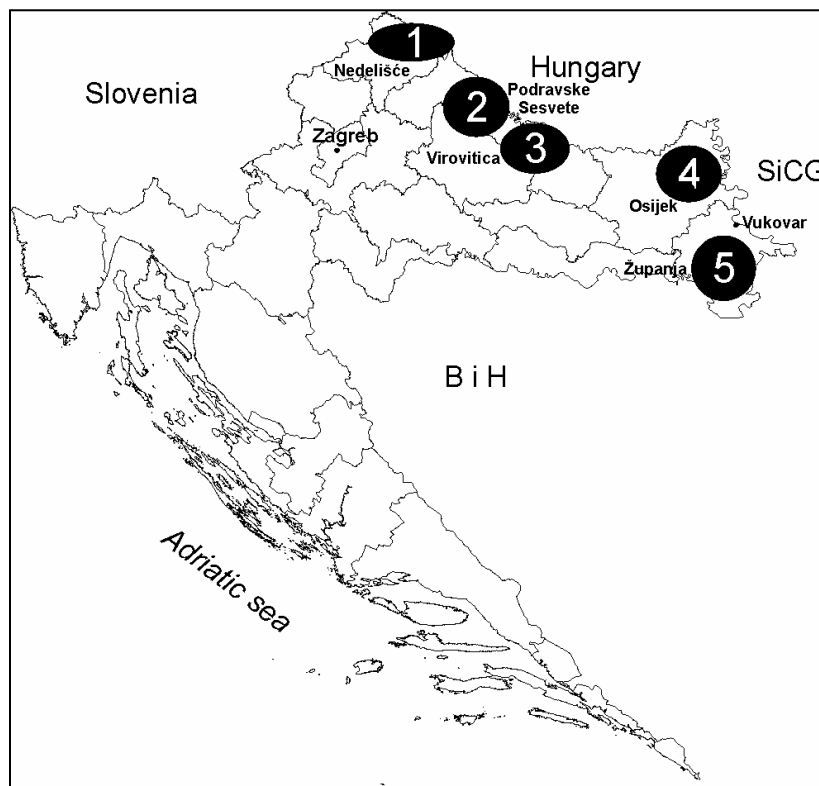

Figure 1. Rhizomania infected areas in Croatia. Marks 1 to 5 are emphasized in Table 1.

Results and Discussion

A total of 139 sugar beet root samples from 72 locations in 9 Croatian counties (Virovitičko-podravska, Varaždinska, Bjelovarsko-bilogorska, Međimurska, Zagrebačka, Koprivničko-križevačka, Osječko-baranjska, Požeško-slavonska and Vukovarsko-srijemska) were analyzed.

The results obtained by DAS-ELISA-test to determine the presence of BNYVV in field samples are summarized in Table 1. BNYVV was found in 27 samples (19.4 %) from 5 counties (Virovitičko-podravska, Međimurska, Koprivničko-križevačka, Osječko-baranjska, Vukovarsko-srijemska) that are situated in the most important sugar beet production regions of Croatia (Figure 1).

Table 1. Results of DAS-ELISA analysis, on sugar beet roots from fields, for BNYVV presence.

Mark in Fig.1	Counties	No. of positive samples / No. of analyzed samples
1	Međimurska	1 / 6
2	Koprivničko-križevačka	1 / 19
3	Virovitičko-podravska	17 / 73
4	Osječko-baranjska	7 / 19
5	Vukovarsko-srijemska	1 / 13
-	Varaždinska	0 / 1
-	Bjelovarsko-bilogorska	0 / 4
-	Požeško-slavonska	0 / 3
-	Zagrebačka	0 / 1

The results of the DAS-ELISA analysis of the sugar beet plants grown on 9 soil samples infected by BNYVV collected from 8 locations in 2 counties (Virovitičko-podravska and Osječko-baranjska) are summarized in Table 2. BNYVV was found in both counties in 5 samples (55.6 %).

Table 2. Results of DAS-ELISA-test analysis of sugar beets grown in 9 different soil samples (+ = BNYVV detected; - = BNYVV not detected).

County	Location	BNYVV
Virovitičko-podravska	Virovitica, Batalija	-
	Novi Gradac	+
	Virovitica, Ševaruša	-
	Lukač, Livade	+
	Virovitica, Karajkovic	-
Osječko-baranjska	Osijek, Brijest	+
	Osijek, Klisa	-
	Tenja, Seleš	+
		+

Results obtained by mRT-PCR indicate that the type A of BNYVV is present in two soils from Seleš.

The results of our survey confirm the presence of rhizomania through the most important Croatian sugar beet growing areas and highlight the distribution of BNYVV in continental parts

of Croatia (Figure 1). BNYVV was found in the roots of sugar beet in the most important sugar beet producing counties e.g. Virovitičko-podravska, Vukovarsko-srijemska and Osječko-baranjska. At some locations we checked virus presence in the soil, which has practical value because BNYVV presence can be verified even before sowing-time allowing the farmers to choose the rhizomania-free plots for growing sugar beets or tolerant varieties to grow in infected plots.

It would be very interesting to analyze samples from other locations, which were not included in this study, in order to obtain a closer and more detailed view of rhizomania distribution in Croatia. Moreover future studies on the molecular aspects of the Croatian BNYVV isolates will be performed in order to provide new data to update BNYVV distribution map.

References

- Asher M. J. C. (1999). Sugar-beet rhizomania: the spread of a soilborne disease. *Microbiol. Today* **26**,120-122.
- Asher M.J.C., Boonham N., Smith P., Walsh K., Tame J., Morris J., Spence N. (1993) Rhizomania. In "The Sugar Beet Crop: Science into Practice" (Cooke, D.A. and R.K. Scott, Eds), pp. 311-346. Chapman & Hall, London,
- Canova, A. (1959). Appunti di patologia della barbabietola. *Informatore Fitopatologico* **9**, 390-396.
- Casarini Camangi, P. (1987). Incidenza della rizomania sulla produzione quali-quantitativa della barbabietola da zucchero. *L'Informatore Agrario*, **43**:149-152.
- Koenig R., Lueddecke P., Haeberlé A.M. (1995). Detection of beet necrotic yellow vein virus strains, variants and mixed infections by examining single-stranded conformation polymorphisms of immunocapture RT-PCR products. *Journal of General Virology* **76**, 2051-2055.
- Kruse M., Koenig R., Hoffmann A., Kaufmann A., Commandeur U., Solovyev A.G., Savenkov I., Burgermeister W. (1994). Restriction fragment length polymorphism analysis of reverse transcription PCR products reveals the existence of two major strain groups of beet necrotic yellow vein virus. *Journal of General Virology*, **75**, 1835-1842.
- Lennefors B.L., Lindsten K., Koenig R. (2000). First record of A and B type beet necrotic yellow vein virus in sugar beets in Sweden. *Eur. J. Plant Pathol.* **106**, 199-201.
- Ratti C., Clover G.R., Rubies Autonell C., Harju V.A., Henry C.M. (2005). A multiplex RT-PCR assay capable of distinguishing beet necrotic yellow vein virus types A and B. *J Virol Methods* **124**, 41-47.
- Šutić D., Milovanović M. (1980). Some factors affecting epidemiology of sugar beet Rhizomania-like disease. In "Proc. 5th Congr. Phytopath. Mediter.", pp. 29-30. Patras, Greece.
- Tamada T. (1999). Benyviruses. In "Encyclopedia of Virology", 2nd ed. (Webster, R.G. and A. Granoff, Eds), pp. 154-160. Academic Press, London.
- Vilčar B. (1996). Rizomanija - nova bolezen slatkorne pese v Sloveniji. Novi izzivi v poljodstvu. In "Zbornik referatov", pp. 299-300.

INCIDENCE OF SUGAR BEET SOIL-BORNE VIRUSES IN SUGAR BEET GROWING COUNTRIES.

C. Ratti¹, L. Bianchi¹, R. Resca¹, M. De Biaggi², V.A. Harju³, C.M. Henry³, E. Jackeviciene⁴, B. Cvjetković⁵ and C. Rubies Autonell¹

¹DiSTA – Plant pathology, University of Bologna, V.le Fanin, 40 - 40127 Bologna - Italy. ²Istituto Sperimentale per le Colture Industriali, Sezione di Rovigo, viale Amendola, 82 I-45100 Rovigo, Italy. ³CSL, Sand Hutton, York, YO41 1LZ, UK. ⁴Lithuanian State Plant Protection Service, Vilnius, LT-11351, Lithuania. ⁵Faculty of Agriculture, Department of Plant Pathology, Svetošimunska 25, Zagreb 10 000, Croatia

Summary

Soil samples from the main sugar beet growing areas of Austria, Belgium, Croatia, Federal Republic of Yugoslavia, France, Germany, Hungary, Italy, Japan, Lithuania, The Netherlands, Poland, Serbia and Montenegro, Spain, Switzerland, United Kingdom and the United States of America (USA) were investigated for the presence of the most important known sugar beet viruses transmitted by *Polymyxa betae* Keskin. Characterization and detection of *Beet necrotic yellow vein virus* (BNYVV), *Beet soil borne virus* (BSBV), *Beet virus Q* (BVQ) and *Beet soil borne mosaic virus* (BSBMV) were obtained using a molecular protocol based on a multiplex RT-PCR reaction. Our results confirm that the A type of BNYVV occurs widely in Europe, the USA and Asia and that the B type occurs most frequently in Northern Europe. BSBV is spread worldwide, BVQ seems to be more typical in European soils and BSBMV is identified only in soil samples from the USA.

Introduction

BNYVV is the type member of the genus *Benyvirus* and causes the disease known as rhizomania. It is, from an economic point of view, the most important sugar beet virus disease. BNYVV was first described in Italy (Canova, 1959) and has since been reported from many sugar beet growing countries in Europe, Asia and the USA.

The genome of BNYVV consists of five plus-sense strands of RNA. On the basis of sequence analysis of RT-PCR products from RNA 1 to 5, three major types of the virus have been identified. Types A and B are distributed worldwide and contain only four RNA species and type P, identified in Europe and Asia, contains RNA 5.

BSBMV is also ascribed to the genus *Benyvirus*, first identified in Texas, it has not been identified outside the USA. BNYVV and BSBMV have similar host ranges, particle size and morphology, are serologically related and have identical genomic organization. Based on the degree of nucleotide and amino acid sequence identity however, the two viruses were confirmed to be distinct species (Lee *et al.*, 2001).

BSBV is a member of the genus *Pomovirus*, it was first detected in the United Kingdom (Henry *et al.*, 1986) and then reported in different countries in Europe, Asia and the USA. Two serotypes were initially described for BSBV, Ahlum and Wierthe (Lesemann *et al.*, 1989). The Wierthe serotype is now considered a distinct virus species, BVQ, based on its genomic properties (Koenig *et al.*, 1998). BVQ has been reported in Belgium, Bulgaria, France, Germany, Hungary, Italy, the Netherlands and Spain (Meunier *et al.*, 2003; Rubies Autonell *et al.*, 2005). BVQ and BSBV are commonly associated and often found in the same field, as BNYVV.

The aim of this work was to update data concerning the incidence of sugar beet soil-borne viruses in the main sugar beet growing countries.

Materials and methods

Sugar beet plants (cv. Asso) were grown in soil samples from the main sugar beet growing areas of Austria, Belgium, Croatia, Federal Republic of Yugoslavia, France, Germany, Hungary, Italy, Japan, Lithuania, The Netherlands, Poland, Serbia and Montenegro, Spain, Swiss, United Kingdom and the USA. Root tissue was later harvested and total ssRNA extracted, as previously reported (Ratti *et al.*, 2005).

Characterization and detection of BNYVV, BSBV, BVQ, BSBMV and *P. betae* were obtained using a molecular protocol based on a multiplex RT-PCR reaction. Primers from recently published methods for specific BNYVV RNA5 and BNYVV type A and B diagnosis (Harju *et al.*, 2005; Ratti *et al.*, 2005) were combined, in a mRT-PCR protocol, with specific primers for *P. betae*, BSBV RNA 2, BVQ RNA 3 and BSBMV RNA 2, designed on the basis of published sequences. A multiplex RT-PCR reaction was empirically optimized and mRT-PCR protocols developed (Ratti *et al.*, unpubl.).

Table 1. Incidence of sugar beet soil-borne viruses in the main sugar beet growing countries.

n.	Isolate	BNYVV			BSBV	BVQ	BSBMV	<i>P. betae</i>	Source
		A	B	P					
1	Austria (1 C79)	x	-	-	x	-	-	x	-
2	Belgium (Antwerpen)	x	-	-	x	x	-	x	C. Bragard
3	Belgium (Brabant)	-	x	-	x	x	-	x	C. Bragard
4	Belgium (Brabant)	-	x	-	x	x	-	x	C. Bragard
5	Belgium (Hainaut)	x	-	-	x	x	-	x	C. Bragard
6	Belgium (Liège)	-	x	-	x	x	-	x	C. Bragard
7	Belgium (Namur)	-	x	-	x	x	-	x	C. Bragard
8	Croatia 1 (Seles)	x	-	-	x	-	-	x	B. Cvjetković
9	Croatia 2 (Tovarnic)	-	-	-	-	-	-	x	B. Cvjetković
10	Croatia 3 (Tovarnic)	-	-	-	x	-	-	x	B. Cvjetković
11	Croatia 4 (Seles)	-	-	-	-	x	-	x	B. Cvjetković
12	Croatia 5 (Seles)	x	-	-	x	x	-	x	B. Cvjetković
13	Croatia 6 (Jospin dvor)	-	-	-	-	x	-	x	B. Cvjetković
14	Croatia 7 (Seles)	-	-	-	-	-	-	x	B. Cvjetković
15	Fed. Rep. of Yugoslavia (Yugo 114/11)	x	-	-	-	-	-	x	I. Macfarlane
16	Fed. Rep. of Yugoslavia (Yugo A14)	x	-	-	-	-	-	x	R. Koenig
17	Fed. Rep. of Yugoslavia (Yugo A15)	x	-	-	-	-	-	x	I. Macfarlane
18	Fed. Rep. of Yugoslavia (Yugo A16)	x	-	-	-	-	-	x	I. Macfarlane
19	Fed. Rep. of Yugoslavia (Yugo A17)	x	-	-	-	-	-	x	R. Koenig
20	France (1999)	-	x	-	-	-	-	x	M. Richard-Molard
21	France (Artenay)	-	x	-	x	x	-	x	R. Resca
22	France (Carroy)	-	x	-	x	x	-	x	R. Resca
23	France (Pihitiviers)	x	-	x	x	-	-	x	P. Houdmon
24	France (Longville) 1	x	-	x	x	x	-	x	M. De Biaggi
25	France (Longville) 2	x	-	x	x	x	-	x	M. De Biaggi
26	France (Longville) 3	x	-	x	x	-	-	x	M. De Biaggi
27	France (Longville) 4	x	-	-	x	x	-	x	M. De Biaggi
28	France (Longville) 5	x	-	x	x	-	-	x	M. De Biaggi
29	Germany (A12)	-	x	-	-	-	-	x	R. Koenig
30	Germany (A13)	-	x	-	-	-	-	x	R. Koenig
31	Germany (Bavarian - A10)	-	x	-	-	-	-	x	E. Schlösser
32	Hungary	x	-	-	-	-	-	x	L. Potyondi
33	Hungary (Celledok I)	x	-	-	x	-	-	x	L. Potyondi
34	Hungary (Celledok II)	x	-	-	x	x	-	x	L. Potyondi
35	Hungary (Fertod)	x	-	-	x	-	-	x	L. Potyondi
36	Hungary (Kaba)	x	-	-	x	-	-	x	L. Potyondi
37	Hungary (LSD)	x	-	-	-	-	-	x	L. Potyondi
38	Hungary (Szolnok)	x	-	-	x	-	-	x	L. Potyondi
39	Hungary (Tampaladony)	x	-	-	x	-	-	x	L. Potyondi
40	Italy (Ancona)	x	-	-	x	-	-	x	R. Resca
41	Italy (Ferrara)	x	-	-	x	x	-	x	R. Resca
42	Italy (Latina)	x	-	-	x	-	-	x	R. Resca
43	Italy (Modena)	x	-	-	-	-	-	x	R. Resca
44	Italy (Oristano)	x	-	-	x	x	-	x	R. Resca
45	Italy (Ravenna)	x	-	-	x	-	-	x	R. Resca
46	Italy (Siena)	-	-	-	x	-	-	x	R. Resca

n.	Isolate	BNYVV			BSBV	BVQ	BSBMV	P. betae	Source
		A	B	P					
47	Japan (11-0)	x	-	-	-	-	-	x	T. Tamada
48	Japan (S2 C74)	x	-	-	-	-	-	x	T. Tamada
49	Japan (S4 C76)	x	-	-	-	-	-	x	T. Tamada
50	Japan (S5 C75)	x	-	-	-	-	-	x	T. Tamada
51	Japan (T-101)	x	-	x	x	-	-	x	T. Tamada
52	Lithuania 02290/39-20	-	x	-	-	-	-	x	E. Jackeviciene
53	Lithuania 02290/39-21	-	x	-	-	-	-	x	E. Jackeviciene
54	Lithuania 02290/39-23	-	x	-	x	-	-	x	E. Jackeviciene
55	Lithuania 02290/39-27	-	x	-	x	-	-	x	E. Jackeviciene
56	Lithuania 02290/39-28	-	x	-	x	x	-	x	E. Jackeviciene
57	Poland	x	-	-	-	-	-	x	M. Jezewska
58	Serbia and Montenegro (Mitrovica)	x	-	-	-	-	-	x	M. De Biaggi
59	Spain (Aimcra 1, Albacete)	x	-	-	x	x	-	x	J. Ayala García
60	Spain (Aimcra 2, Albacete)	x	-	-	x	x	-	x	J. Ayala García
61	Spain (Aimcra 3, Ciudad Real)	-	-	-	x	x	-	x	J. Ayala García
62	Spain (Aimcra 4, Ciudad Real)	x	-	-	x	x	-	x	J. Ayala García
63	Spain (Aimcra 5, Ciudad Real)	x	-	-	x	x	-	x	J. Ayala García
64	Spain (Aimcra 6, Ciudad Real)	x	-	-	x	x	-	x	J. Ayala García
65	Spain (Carpio)	-	-	-	x	-	-	x	R. Resca
66	Spain (Castillo de Ontelo - 327)	x	-	-	x	-	-	x	R. Resca
67	Spain (Castillo de Ontelo - 328)	x	-	-	x	-	-	x	R. Resca
68	Spain (Langa)	-	-	-	x	-	-	x	R. Resca
69	Spain (Valladolid)	x	-	-	x	x	-	x	R. Resca
70	Switzerland (A20)	x	-	-	x	-	-	x	A. Hani
71	Switzerland (Rio Zurich A20)	x	-	-	-	-	-	x	A. Hani
72	The Netherlands (1545)	-	x	-	-	-	-	x	-
73	The Netherlands (A14)	x	-	-	-	-	-	x	-
74	The Netherlands (D646 c)	x	-	-	-	-	-	x	-
75	The Netherlands (Noord Beveland)	x	-	-	x	-	-	x	W. Heijbroek
76	UK (Barton Mills - Suffolk)	x	-	-	x	-	-	x	C. Henry
77	UK (Blaxhall - Suffolk)	-	x	-	x	-	-	x	C. Henry
78	UK (Boyton - Suffolk)	x	-	-	x	-	-	x	C. Henry
79	UK (Great Livermere - Suffolk) Leaves	-	x	-	-	-	-	-	C. Henry
80	UK (Knodishall - Suffolk)	x	x	-	x	-	-	x	C. Henry
81	UK (P11, Icklingham - Suffolk)	x	-	-	-	-	-	x	C. Henry
82	UK (P12, Osberton Grange - Notts.)	x	-	x	-	-	-	x	C. Henry
83	UK (P15, Barnaham - Norfolk)	x	-	-	-	-	-	x	C. Henry
84	UK (P16, Waldringfield - Suffolk)	x	-	-	-	-	-	x	C. Henry
85	UK (P18, Swaffham - Norfolk)	-	x	-	-	-	-	x	C. Henry
86	UK (P2, Great Livermere - Suffolk)	x	-	-	-	-	-	x	C. Henry
87	UK (P22, Campsey ash - Suffolk)	-	x	-	-	-	-	x	C. Henry
88	UK (P26, Banham - Norfolk)	-	x	-	-	-	-	x	C. Henry
89	UK (P27, Stourton - Staffs)	-	x	-	-	-	-	x	C. Henry
90	UK (P31, Waldringfield - Suffolk)	x	-	-	-	-	-	x	C. Henry
91	UK (P34)	x	-	-	-	-	-	x	C. Henry
92	UK (P5, Great Livermere - Suffolk)	x	-	-	-	-	-	x	C. Henry
93	UK (P6, Barnaham - Norfolk)	x	x	-	-	-	-	x	C. Henry
94	UK (P8, Butley - Suffolk)	x	-	-	-	-	-	x	C. Henry
95	UK (West Stow)	x	-	-	x	x	-	x	C. Henry
96	UK (Wood Farm)	x	-	-	-	-	-	x	C. Henry
97	United States (California)	x	-	-	-	-	-	x	C. Rush
98	United States (Colorado)	-	-	-	x	-	x	x	C. Rush
99	United States (Michigan)	x	-	-	-	-	-	x	C. Rush
100	United States (Minnesota 2)	-	-	-	-	-	x	x	C. Rush
101	United States (Minnesota)	x	-	-	-	-	-	x	C. Rush
102	United States (Texas)	-	-	-	-	-	x	x	C. Rush
103	United States (1 C84)	x	-	-	-	-	-	x	K. Richards
104	United States (2 C57)	x	-	-	-	-	-	x	K. Richards
105	United States (3 C57)	x	-	-	-	-	-	x	K. Richards
106	United States (Salinas)	x	-	-	x	-	-	x	M. De Biaggi

Results and discussion

BNYVV was identified in all countries from which soil was obtained. Our results confirm that the A type of BNYVV occurs very widely in Europe, the United States and Asia and that the B type occurs most frequently in Northern Europe: Germany, France, Belgium, Lithuania, The Netherlands and United Kingdom. Coat protein and P25 protein nucleotide and amino acid sequences of new BNYVV Lithuanian isolates show more than 99% identity with other B type

isolates (data not shown) confirming a highly conserved genome among isolates within the same type (Koenig and Lennefors, 2000).

BSBV was successfully detected on several different isolates from Europe and Asia, often in mixed infections with BNYVV but also in single infections in samples from Croatia, Italy and Spain. In the United States just two soil samples revealed the presence of BSBV in mixed infections with BNYVV or BSBMV.

BVQ, in association with BNYVV and BSBV, was detected in samples from Belgium, Croatia, France, Italy, Lithuania, United Kingdom, Spain and Hungary. Samples containing a mixed infection of BVQ and BSBV were identified just once in Spain and single BVQ infection seemed to occur in two samples from Croatia. Finally, only soil samples from USA (Minnesota, Texas and Colorado) were found to be infected by BSBMV.

Several authors have reported simultaneous infection of different virus species, in the same sugar beet plant that could affect disease symptom expression (Rush, 2003). The pathogenicity of BSBV, BVQ and BSBMV and their role in the epidemiology of rhizomania syndrome currently therefore remains an important subject for study.

References

- Canova A. (1959). Appunti di patologia della barbabietola. *Informatore Fitopatologico* 9, 390-396.
- Harju V.A., Skelton A., Clover G.R.G., Ratti C., Boonham N., Henry C.M. and Mumford R.A. (2005). The use of real-time RT-PCR (TaqMan[®]) and post-ELISA virus release for the detection of Beet necrotic yellow vein virus types containing RNA 5 and its comparison with conventional RT-PCR. *Journal of Virological Methods*, 123, 73-80.
- Henry C.M., Barker I., Jones R.A.C. and Coutts R.R.A. (1986). Occurrence of a soil-borne virus of sugar beet in England. *Plant Pathol.* 35, 585-591.
- Koenig, R. and Lennefors B. -L. (2000). Molecular analyses of European A, B and P type sources of beet necrotic yellow vein virus and detection of the rare P type in Kazakhstan. *Arch. Virol.* 145, 1561-1570.
- Koenig R., Pleij C.W., Beier C. and Commandeur U. (1998). Genome properties of beet virus Q, a new furo-like virus from sugarbeet, determined from unpurified virus. *J. Gen. Virol.* 79, 2027-2036.
- Lee L., Telford E., Batten J., Scholthof G.K-B., Rush C.M. 2001. Complete nucleotide sequence and genome organization of *Beet soilborne mosaic virus*, a proposed member of the genus *Benyvirus*. *Arch. Virol.* 140, 2443-2453.
- Lesemann D.E., R. Koenig R., Lindsten K. and Henry C. (1989). Serotypes of beet soil-borne furovirus from FRG and Sweden. *Bull. EPPO/OEPP* 19, 539-540.
- Meunier, A., Schmit, J.F., Stas, A., Kutluk, N., Bragard, C. (2003). Multiplex reverse transcription-PCR for simultaneous detection of *Beet necrotic yellow vein virus*, *Beet soilborne virus*, and *Beet virus Q* and their vector *Polymyxa betae* Keskin on sugar beet. *Applied and Environmental Microbiology* 69, 2356-2360.
- Ratti C., Clover G.R.G., Rubies Autonell C., Harju V.A and Henry C.M. (2005). A multiplex RT-PCR assay capable of distinguishing beet necrotic yellow vein virus types A and B. *Journal of Virological Methods*, 124, 41-47.
- Rubies Autonell C., Ratti C., Resca R., De Biaggi M. and Ayala García J. (2005). First Report of *Beet virus Q* in Spain. *Plant Disease*, accepted for publication 6 September 2005.
- Rush C.M. (2003). Ecology and epidemiology of Benyvirus and plasmodiophorid vectors. *Annual Review of Phytopathology* 41, 567-592.